

Issue 78

PS

1959 Series

# THE PREVENTIVE MAINTENANCE MONTHLY

I DON'T GIVE A  
DING DONG HOW  
YOU INTERPRET THE  
AR... SOP IN THIS  
OUTFIT SAYS...  
YOU SHINE BOOTS  
AT 0600 EVERY  
MORNING.

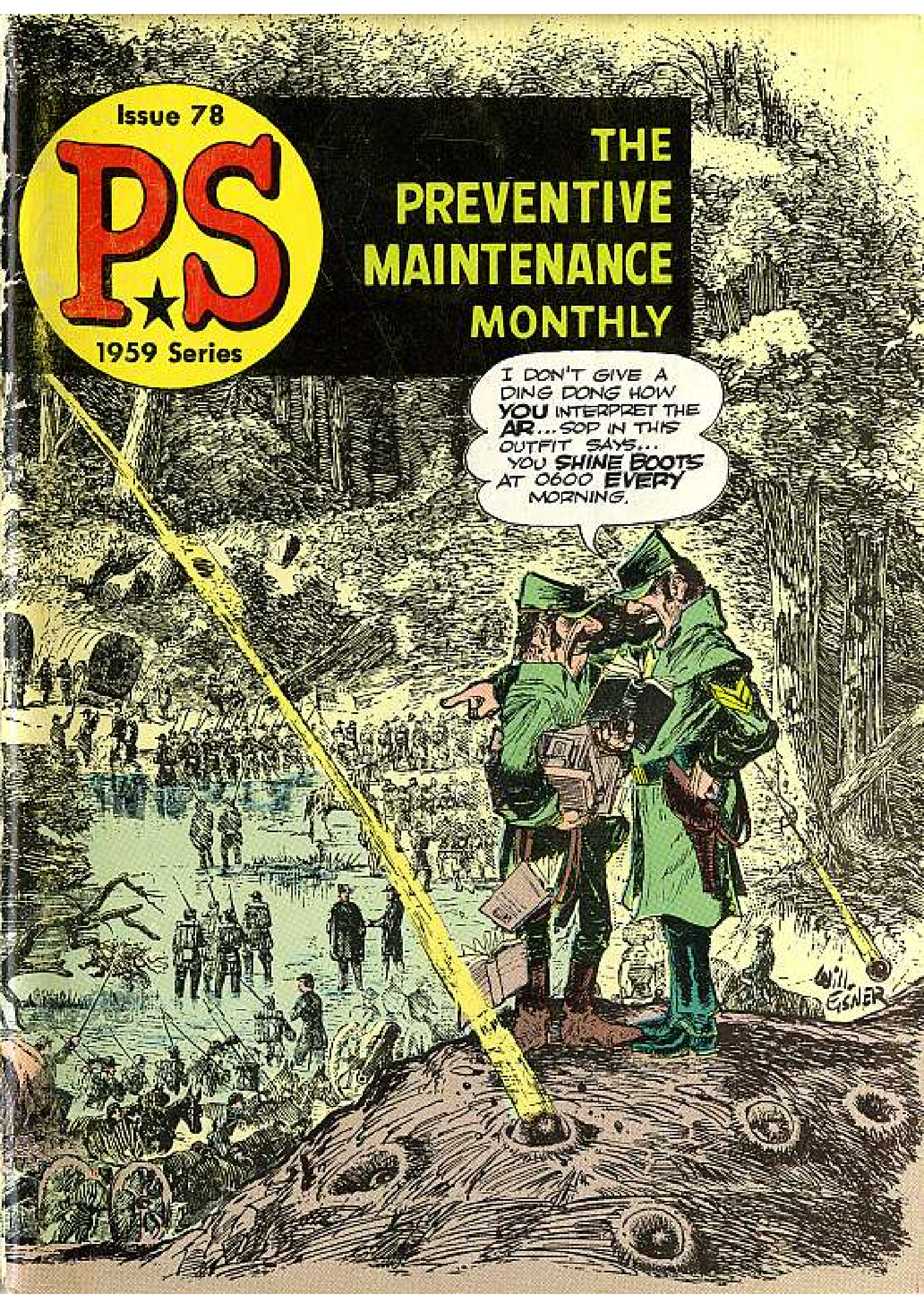

# Now... Like Then —

An Army-wide directive (like an AR) is designed to serve as a guide for subordinate commands. Command and unit operating procedures pin down just how such directives apply under local conditions. That's why, when the word gets to company, battalion and battle group level, it's like this:  
Until told otherwise, you follow your own outfit's SOP—(Standing Operating Procedure)—that's the official word as far as you're concerned. (See Page 29)

Issue 78  
**PS**  
1959 Series

## THE PREVENTIVE MAINTENANCE MONTHLY

I DON'T GIVE A DING DONG HOW YOU INTERPRET THE AR... SOP IN THIS OUTFIT SAYS... YOU SHINE BOOTS AT 0600 EVERY MORNING.



WILL EXNER

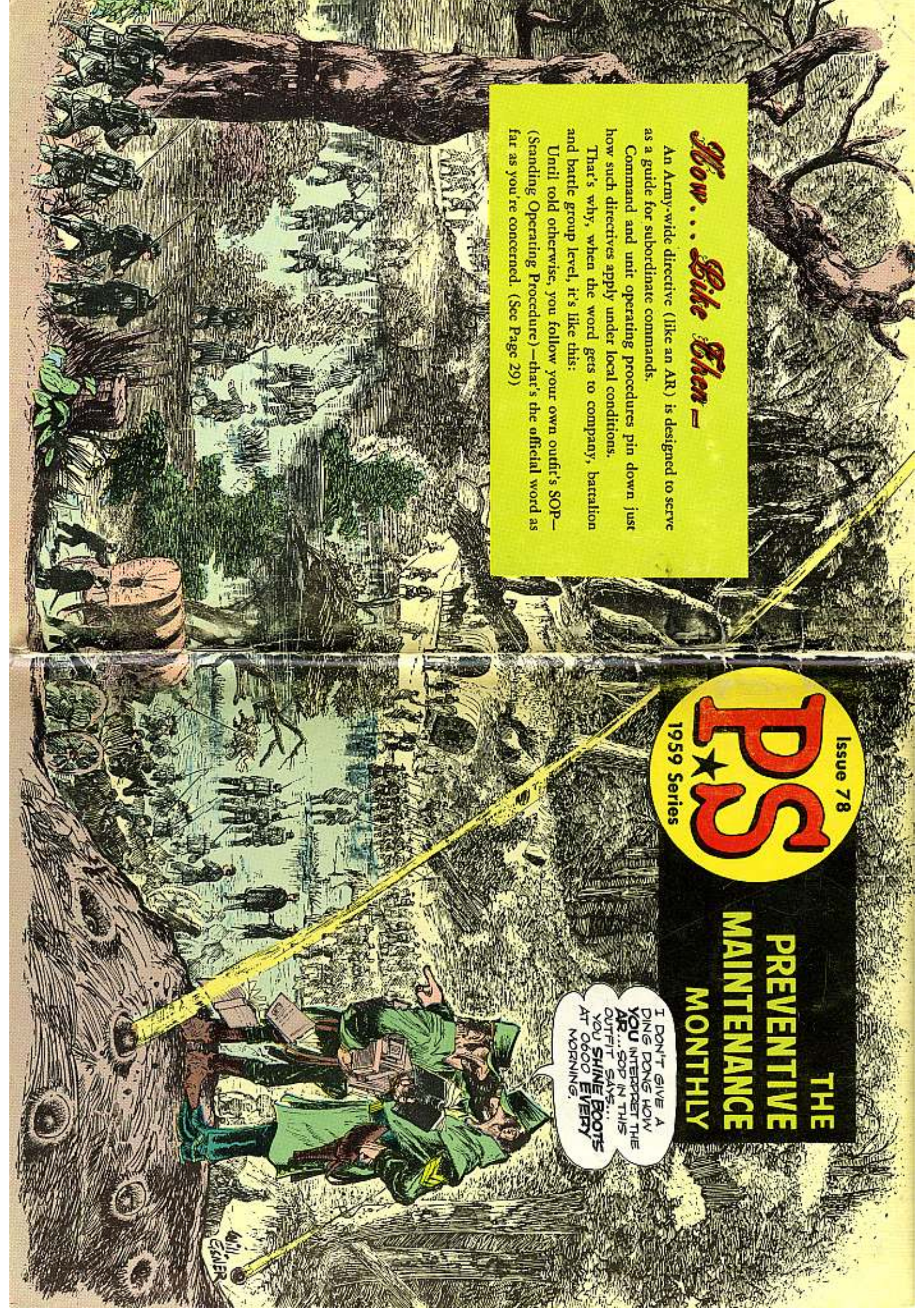

# 'SUPER' CHECKUP



Dear Half-Mast,

What's with this new "supervisor's inspection" we been hearing about on tactical vehicles? There doesn't seem to be any guide line to go by, on when and how this checkup is to be made.

Sgt W.V.J.

Dear Sgt W. V. J.,

Like you said, there're no hard-and-fast rules on the "supervisor's inspection." It was planned that way to let your local commander set up details that fit the particular needs of your unit.

The guide rules on these new inspections are laid out in paras 4c and 122b of the new TM 9-2810 (4 Aug 58), "Tactical Motor Vehicle Preventive Maintenance, Supply, Inspection and Training Procedures."

Higher level commanders can set up the supervisor's inspection, in any way they feel the need, to cover special situations in their commands. But, normally, it's intended that your local commander—company, battery or battalion, for example—will make up all the rules about how often to inspect, how much to inspect, what to inspect, what to do about deficiencies found and anything else he thinks is necessary.

It's a strictly 2nd echelon level inspection and service that replaces the old B and C services that had to be taken care of on a definite schedule, according to the old TM 9-2810.

The supervisor's inspection plan lets the unit commander pass up services that're not needed. The goal is to save the mechanic's time and to get maximum operating efficiency in each unit by cutting down the number of vehicles sitting around waiting for maintenance.

After all, the supervisor's inspection is intended to be an organizational deal to keep tabs on how well 1st echelon maintenance is going and catch any 1st or 2nd echelon deficiencies on the spot.

That's why it's conducted by people in your outfit with technical know-how . . . in this case, by your own organizational maintenance people who've been doing the servicing on the equipment they're inspecting. You don't need to clutter up your outfit's maintenance files with any formal records on it. Instead, just correct the deficiencies you find on the spot—or refer 'em to your support outfit pronto when they're 3rd echelon jobs. That makes it a maintenance servicing deal, besides being an informal inspection.

The command-type inspection, which is also formal, doesn't particularly use only people with technical know-how, because they've got a different purpose. Instead of looking for maintenance flaws, the command-type inspection is used to check the operating efficiency and mission-readiness of your whole unit. That includes administration, training, you, your gear and everything else in the unit—not just vehicles.

*Half-Mast*

**THE**  
**PREVENTIVE**  
**MAINTENANCE**  
**MONTHLY**

Issue No. 78

1959 Series

Published by the Department of the Army for the information of organizational maintenance and supply personnel. Distribution is made through normal publication channels. Within limits of availability, older issues may be obtained direct from Preventive Maintenance Agency, Raritan Arsenal, Metuchen, New Jersey.

## IN THIS ISSUE

### ARTICLES

|   |    |
|---|----|
| M48A2 Tank: General Rundown               | 2  |
| Electric Welding: Ground Clamp Tips       | 16 |
| Hot Weather Tips on Vehicles              | 18 |
| General Mechanic's Tool Kit               | 20 |
| SPAL: Paper U-Joint Lube Fitting          | 25 |
| TD-18 HHC Tractor: Two Pups You Need      | 26 |
| M3 Food Tasting Kit: New One Coming       | 26 |
| What IS A Directive?                      | 29 |
| TM 10-1400: New PM "Bible" for GM Units   | 37 |
| Coaxial Cables: Vinyl Tape Em.            | 43 |
| Grounding Racks: Use Right Adapters       | 44 |
| PS-10 Redars: Lube Gears Right            | 45 |
| Nine BB-401/U Batteries: Check and Charge | 47 |
| Nike-Ajax Tracking Radar: Ground Clutter  | 52 |
| Nike-Ajax: Use The Right Fuse             | 52 |
| Nike-Ajax: Use Mirror To Check Orings     | 54 |
| Nine Log Books: Keep Up To Date           | 55 |
| Nikes: New Toggle Switch Boot             | 55 |
| Cats: New Track Shoe Nuts and Bolts       | 56 |
| Rotary Compressors: Use The Right Oil     | 57 |
| H-13 Whirlwinds: Control Disk Drag        | 58 |
| Accuracy: Is Yours A Gas Chamber?         | 59 |
| Whirlwinds: Block Off Pigeon Nests        | 62 |
| Cleaning Solvent: Filter and Re-Use       | 63 |
| Fuel Injectors: (AOS) 895-5; Color Code   | 64 |

### DEPARTMENTS

|                      |      |
|----------------------|------|
| Connie Road          | 25   |
| Joe's Dope           | 29   |
| Question and Answer  | 37   |
| Contributions        | 62   |
| Connie Road's Briefs | B.C. |

PS wants your ideas and contributions, and is glad to answer your questions. Just write to: Sgt Half-Mast, PS, Raritan Arsenal, Metuchen, New Jersey. Names and addresses are kept in confidence. The printing of this publication has been approved by the Director of the Bureau of the Budget (27 Apr 56).

### DISTRIBUTION:

In accordance with requirements submitted on DA Form 12.



# YOUR M48A2

That generous relative of yours—your old Uncle Sam, that is—is handing you tankmen the latest thing in the medium tank field. It's the M48A2—the one with the fuel injection system. So here are some pointers that will help you nurse this new baby.

## THE ONCE-OVER BEFORE STARTING

**OVM** (on-vehicle material)  
 Street light in sight?  
 \* Give fuel pressure in hand lead?



\* When gun's in travel position

Safety, fire extinguisher ready to go?  
 When you start, don't forget the fire guard.



Light in view O.K.?

Check for leaks in and outside. Start start if you smell gas in driver's compartment (heater line could be loose.)



# TANK AND YOU

Turnover handle lock held?



Pubs: Got 'em all?  
 TM 9-7622 (41E 58)  
 L O 9-7022 (23 SEPT 57)  
 WEIGHTS RECORDED 800K  
 (DA FORM 9-13-9-13-1)  
 TOWED VEHICLE AND  
 EQUIPMENT OPERATION RECORDED  
 (DA FORM 2145)  
 ACCIDENT-IDENTIFICATION CARD  
 (DD FORM 518)  
 ACCIDENT FORM (SF 91)

Now dear... get any leaks off that might stop air circulation in the engine compartment and that might turn on fuel up the turret handle



**Oil levels:**  
 Drain main oil above the fuel mark.  
 Engine oil at the fuel mark.  
 Auxiliary engine oil at the fuel mark.

Engine compartment: check lid for lubricate lock by hand cranking.



Suspensions: check anything that'll get the tracks in need in good... check for loose tracks...



# STARTING 'ER UP

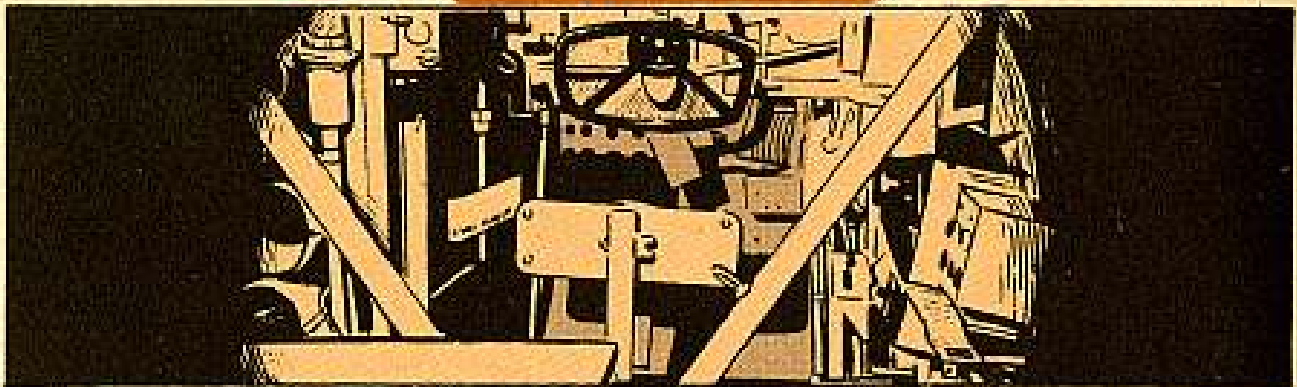

**1** SHIFT LEVER TO PARK.

**2** SET PARKING BRAKE.

**3** RADIO AND ALL ACCESSORY SWITCHES OFF.

**4** FUEL VALVE CONTROL

Turn knob to either **RIGHT ON** or **LEFT ON**. After engine's warmed up, you can put it on **BOTH ON**.

Electric fuel pumps cut out and the main engine pumps take over in the **BOTH ON** position.

**5** FLIP MASTER RELAY SWITCH ON. THE MAIN ENGINE WARNING LIGHT AND MASTER RELAY WARNING LIGHT SHOULD COME ON.

ALSO, THESE ON THE INSTRUMENT PANEL:

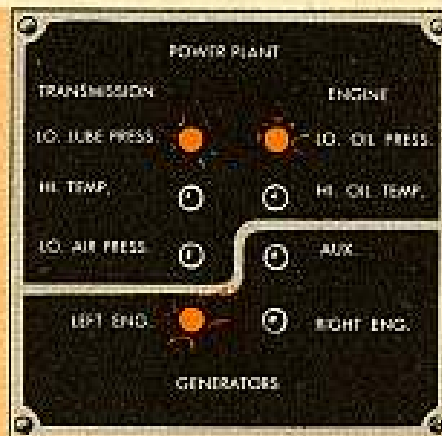

- ◀ TRANSMISSION LOW OIL PRESS. WARNING LIGHT
- ◀ ENGINE LOW OIL PRESSURE WARNING LIGHT
- ◀ MAIN ENGINE GENERATOR WARNING LIGHT

**6****AUXILIARY GENERATOR** Fire up Li'l Joe if y'r batteries are down or the weather 25° chilly or below.

TURN TO START

OFF  
RUN  
STARTTHEN!  
TURN TO RUN  
POSITION.

Run for about 5 minutes \*specially when it's cold outside, then go ahead.

**REMEMBER:**

Keep y'r eye out for Li'l Joe's low oil and generator warning lights.

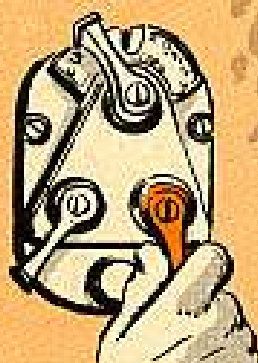
**IF** batteries are dead or too low to close master relay, use a slave hook-up from a live tank or handstart the auxiliary generator engine. But make darn sure the master relay switch is OFF. When handstarting, Little Joe auxiliary generator switch should be on RUN.**7****BEFORE STARTING MAIN ENGINE**CHECK FOR **HYDRO-STATIC LOCK!!****ON** these hot-shot fuel-injection jobs, hydro-lock doesn't happen very often—but it's safer to check just in case you're on the short end of the odds.**WITH MAGNETOS OFF HOLD STARTER ON START AND LET STARTER CRANK ENGINE AT LEAST 5 TIMES. IF ENGINE JAMS YOU CAN FIGURE YOU GOT HYDROSTATIC LOCK...****STOP**

KILL THE MASTER RELAY SWITCH



Then remove a spark plug from each cylinder and pump out any liquids that may be in there by turning over the engine with starter.



THE FULL DOPE ON THIS IS IN TB9-2800-20-10 (3 NOV 58)

**NOW...** OPEN HULL DRAIN VALVE AND FLUSH OFF GASOLINE WITH WATER—

If necessary tow tank out of area and let it sit for awhile so fumes can evaporate before starting.

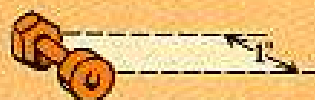
**8****NOW!** IF EVERYTHING CHECKS OUT, SET HAND THROTTLE ONE INCH FROM PANEL. THIS SHOULD REV IT UP TO ABOUT 1000 RPM.

**9**

FLIP MAGNETO SWITCH TO BOTH.

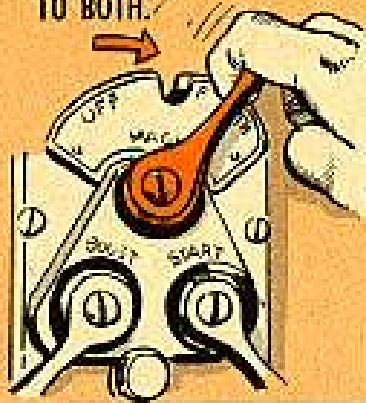
**10**

SQUEEZE STARTER AND BOOSTER TOGETHER.

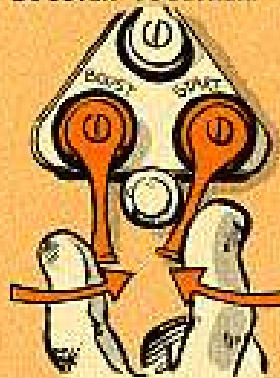
**11**

WORK PRIMER AS ENGINE IS TURNING OVER. AMOUNT OF PRIMING DEPENDS ON HOW COLD YOUR ENGINE IS.

**IF** it's hot—little or no priming. Remember—priming before engine turns over doesn't do it any good and may cause hydrostatic lock. Don't pump accelerator pedal.

**12**

WHEN SHE STARTS—LET GO STARTER AND HOLD BOOSTER UNTIL SHE REVS UP TO ABOUT 500 RPM.

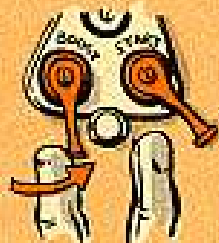

**WATCH IT,** though—the booster has a life of only five minutes of continuous operation—so don't overdo it.

**IF** cranking engine for about 30 seconds fails to start it, release the starter and booster. Wait five minutes to let booster coil and starter cool off before trying again. Never hang on to those switches for more than 30 seconds.

**13**

IF YOU'VE BEEN RUNNIN' LI'L JOE...

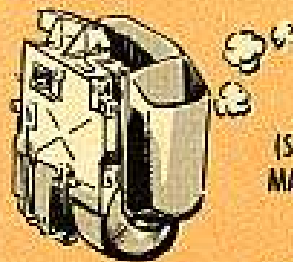

(STARTED BEFORE MAIN ENGINES.)

YOU CAN TURN IT OFF NOW.

**14**

THE FUEL GAGES SHOULD READ FULL.



AND THE OIL INDICATOR PRESSURE GAGE NEEDLE SHOULD BE WORKING

**15**

**WARNING LIGHTS** — All warning lights should go off now if everything's on the up and up. If low oil pressure and main engine generator lights come on at low idle (650 RPM), but go out when you rev up the engine, it's hunky-dory.

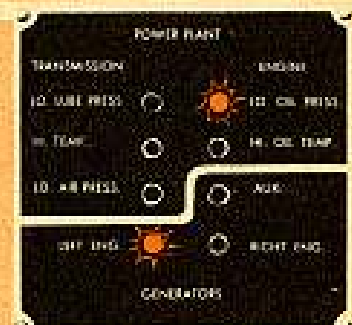

# MOVING OUT

ADJUST HAND THROTTLE TO RUN ENGINE A LITTLE ABOVE HIGH IDLE... (1000 TO 1100 RPM)



LET IT WARM UP FOR 5 MINUTES BEFORE MOVING OUT

## OIL PRESSURE GAGE

WITH OE-50, SHOULD READ 60-70 PSI...

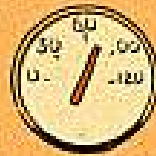

WITH OE-10 IN CRANKCASE, IT SHOULD BE 35-50 PSI.



TRANSMISSION OIL LEVEL HOTCHECK.



SHOULD BE AT THE FULL MARK

**IF** for any reason your engine doesn't seem to be playing a smooth tune, call a mechanic. He'll run a magneto check like this:

SET HAND THROTTLE



SO THE WARMED ENGINE WILL REV AT 2500 RPM. THEN —

FLIP MAGNETO SWITCH TO **F** POSITION...

LISTEN IF THERE'S A DROP IN RPM



(MORE THAN 225) OR IT SOUNDS LIKE A PLUG IS MISFIRING. THERE SHOULD BE A SLIGHT RPM DROP, BUT NO SPITTING OR SPUTTERING.

AFTER **F** POSITION CHECKS OUT, FLIP THE SWITCH TO **BOTH**.



AND RUN FOR ABOUT A MINUTE. THIS IS TO CLEAR ANY CARBON FROM THE PLUGS...

THEN FLIP SWITCH TO **A** POSITION...



'N LISTEN AGAIN FOR ANY BIG DROP IN RPM (MORE'N 225) OR MISFIRING PLUGS.

WHEN TEST IS COMPLETE, TURN SWITCH BACK TO **TH**...

RELEASE THROTTLE, 'N LET 'ER TAPER OFF TO IDLE. HE'LL NEVER RUN



ENGINE MORE THAN ONE MINUTE IN EITHER **F** OR **A** POSITION

**IF** engine acts up in either **F** or **A**, your mechanic will know your vehicle has ignition troubles.



**IF** engine or transmission warning lights scream red... STOP IMMEDIATELY... and start looking for the trouble. The transmission LO, LUBE PRESS warning light may not go out until 1600 RPM with the transmission hot—so don't sweat.



Another way your mechanic can spot what's bothering your vehicle is with a...



# STALL CHECK

IT'S DONE LIKE THIS:

1

LOCK BRAKES:



SHIFT TO PARK

PRESS ON  
BRAKE PEDAL



2

ENGINE SHOULD BE AT NORMAL  
OPERATING TEMPERATURE.

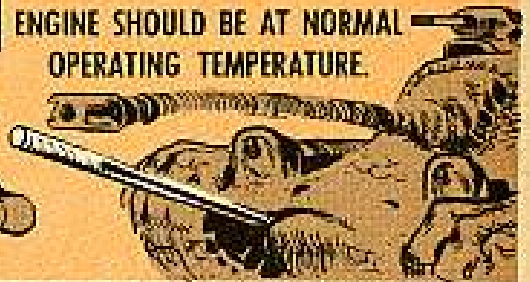

ENGINE UNDER LOAD:

1

SHIFT TO HIGH.



2

OPEN THE THROTTLE ALL THE WAY  
WITH A SLOW . . . STEADY PRESSURE ON  
THE ACCELERATOR PEDAL . . .



THE TACHOMETER  
SHOULD LEVEL OFF BETWEEN 2400  
AND 2600 RPM.

**IF** tachometer levels off below 2400, the vehicle has either ignition, air intake or fuel troubles. This includes the air cleaners and ducts. If the tach goes all the way up to 2800 RPM the transmission is slipping. In either case the mechanic will check over the engine and transmission and get the trouble fixed before you pull out of the tank yard.

ENGINE WITH NO LOAD:

1

SHIFT TO  
PARK . . .

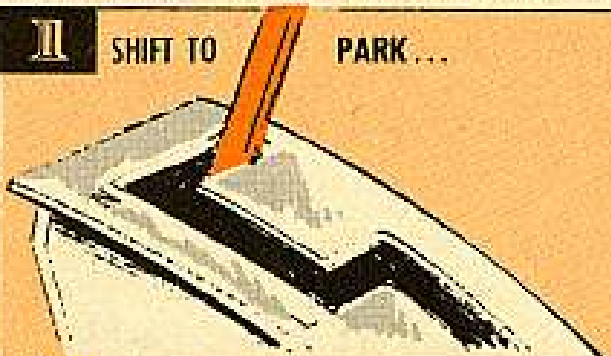

2

AGAIN SLOWLY ACCELERATE TO  
FULL THROTTLE . . .



TACHOMETER  
SHOULD LEVEL OFF AT ABOUT 2800-  
2840 RPM AND HOLD STEADY.

**IF** it's above or below that mark, the engine or engine governor is not in top shape. Better check and find out why before hitting the road.

**THESE TESTS MUST NEVER EXCEED 30 SECONDS OR THE TRANSMISSION MAY OVERHEAT.**

# SHIFTING

**I**N the M48A2 tank, the shift lever comes out of the floor—like most of those pre-World War II automobiles. It was designed to give the driver better control when shifting.



**NEUTRAL** PUSH SHIFT CONTROL TO THE LEFT.



**PARK** (AT THE EXTREME RIGHT)

WHEN PARKING BRAKE IS SET THE STEERING WHEEL CONTROL IS LOCKED...



MOVING LEVER INTO PARK DOESN'T AUTOMATICALLY LOCK THE BRAKE. THE BRAKE PEDAL MUST BE JAMMED DOWN



AFTER THE LEVER IS PUT IN PARK, TO RELEASE BRAKE, PRESS DOWN ON

PEDAL AND SHIFT TO NEUTRAL. IF YOU'RE UNDERWAY, AND YOUR STEERING WHEEL IS LOCKED... IT'S NOT THE TANK, YOU JUST DIDN'T RELEASE THE PARKING BRAKE

ALL THE WAY.

**LOW** PULL SHIFT CONTROL LEVER DOWN ONE NOTCH.



**HIGH** PULL SHIFT CONTROL LEVER DOWN ONE NOTCH.



**REVERSE** PUSH SHIFT LEVER FROM RIGHT TO LEFT AND PULL DOWN ALL THE WAY.



MAKE SURE TANK IS AT A DEAD STOP BEFORE MOVING THE TANK TO THE REAR OR SWITCHING FROM A REVERSE TO A FORWARD MOVEMENT

# OPERATIONAL TIPS

**REMEMBER:** A SHARPER TURN CAN BE MADE IN LOW THAN IN HIGH.

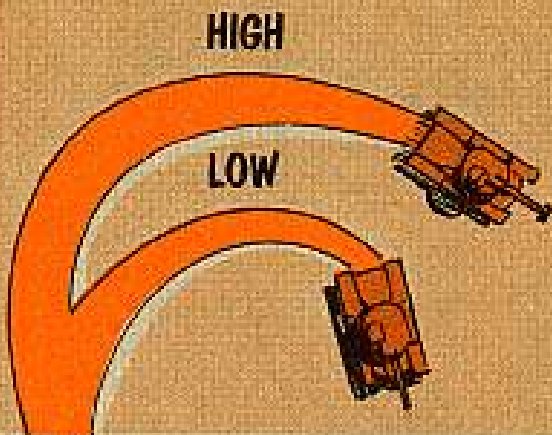

ACCELERATE **EASY**

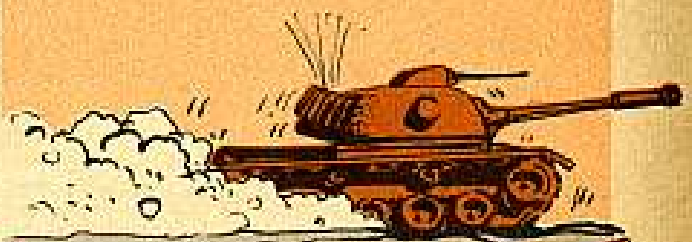

(You might strain engine cooler fans and gear train with quick, jerky jabs on the pedal.)

TAKE OFF IN **HIGH** ON FIRM GROUND.

USE **LOW** WHEN IT'S ROUGH OR MARSH GROUND.

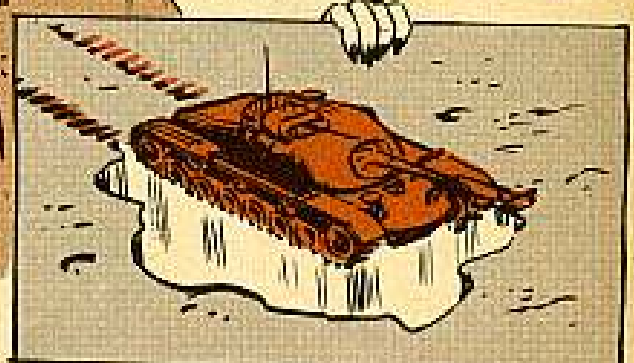

DOWN SHIFT FROM HIGH TO LOW ONLY UNDER 7 MPH OR YOU'LL GET A BIG JERKY MOVEMENT AND MAYBE A BUSTED TRANSMISSION.

WHEN MAKING A HIGH TO LOW SHIFT, STEP ON GAS HARD FOR A QUICK TWO SECONDS, AND PULL SHIFT LEVER INTO LOW. LEAVE YOUR FOOT ON THE GAS PEDAL WHEN YOU'RE DOING THIS...

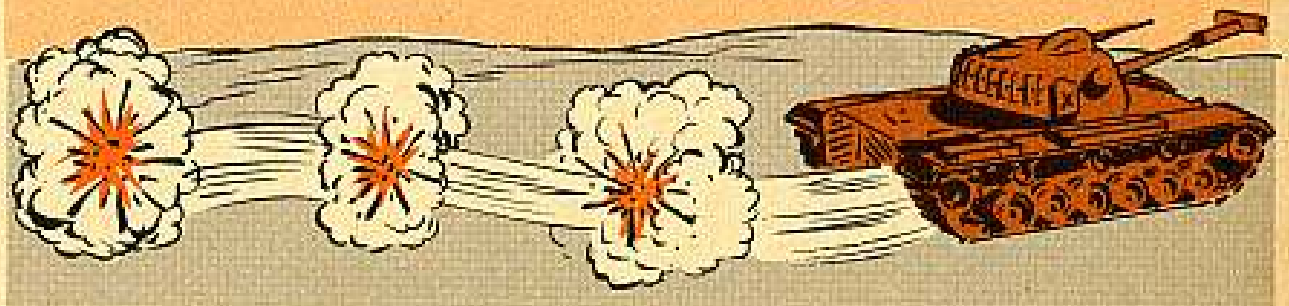

UPSHIFT BETWEEN  
7 AND 11 MPH...



AND EASE UP  
ON THE GAS  
SLIGHTLY  
WHEN SHIFTING.

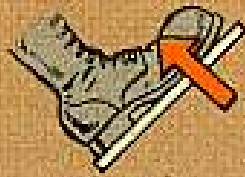

USE  
LOW



AND YOUR BRAKE

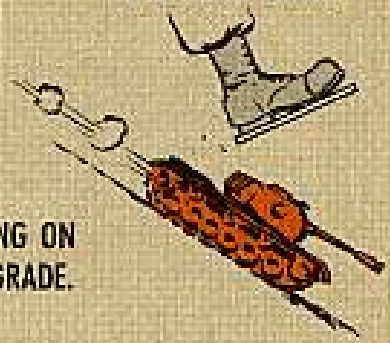

WHEN GOING ON  
A DOWN-GRADE.

REMEMBER REVERSE RANGE IS TO BE USED FOR  
BRAKING PURPOSES ONLY IN AN EMERGENCY.

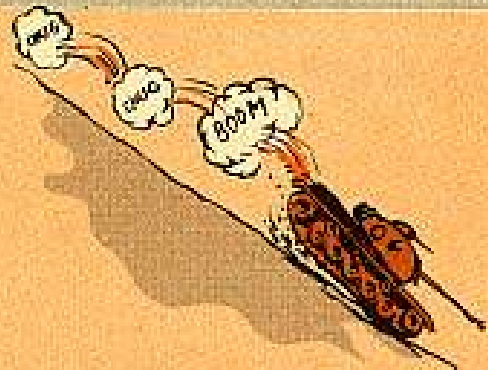
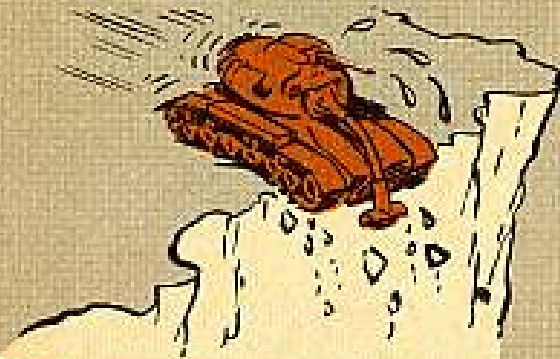

... AND WHEN GOING DOWN STEEP GRADES  
DON'T LET ENGINE STALL OUT ON YOU.

**A HIGH RPM OR A WIDE OPEN THROTTLE  
WITH NO LOAD IS BAD ON YOUR ENGINE.**

DON'T SWEAT IF DURING A  
STEER THE TRANSMISSION  
LOW-PRESSURE WARNING LIGHTS  
FLASH ON AND OFF, ON AND OFF.



IT'S OK AS LONG AS IT  
STAYS OFF WHEN  
YOU'RE ON A STRAIGHT-  
A-WAY.

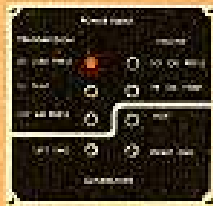

OVERHEATING? IF THE ENGINE AND  
TRANSMISSION SEEM TO BE WORKING  
NORMALLY ... SHIFT TO NEUTRAL  
AND RUN ENGINE AT HIGH  
SPEED (2400 RPM) FOR  
ABOUT 5 MINUTES UNTIL THE  
WARNING LIGHTS GO OUT.



FLIP YOUR EYE ON  
THE INSTRUMENT PANEL  
EVERY SO OFTEN.

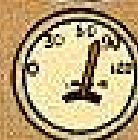
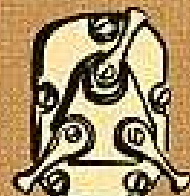
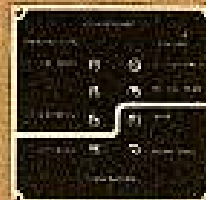
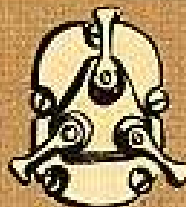



# STEERING



**A LIGHT,** steady pressure on the wheel gives a smooth turn. Avoid quick jerks with the wheel. Movement can be better controlled by good footwork on the gas pedal 'cause steering improves as the transmission speed increases.

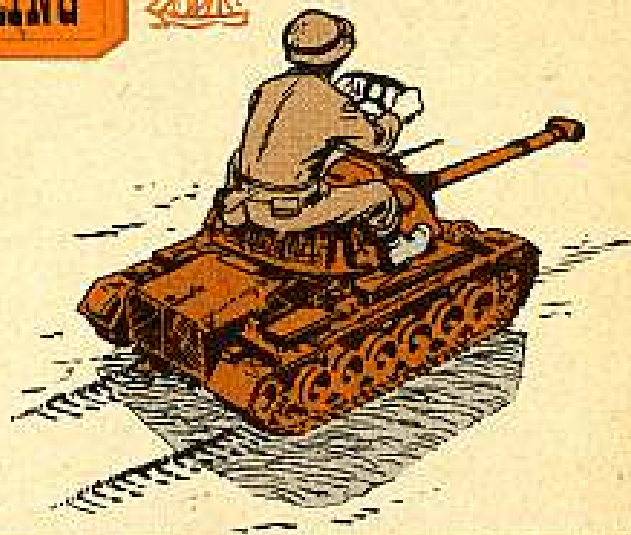

## FORWARD:



TO GO RIGHT...

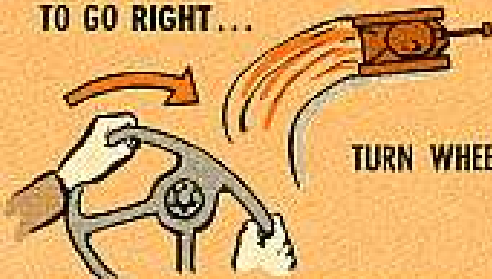

TURN WHEEL RIGHT

TO GO LEFT

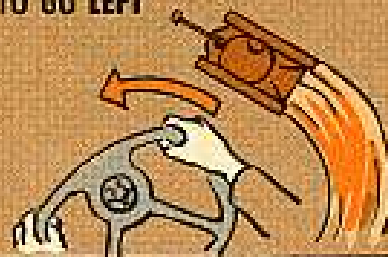

TO PIVOT  
(NEUTRAL STEER)  
STOP  
SHIFT TO NEUTRAL



TO PIVOT RIGHT...

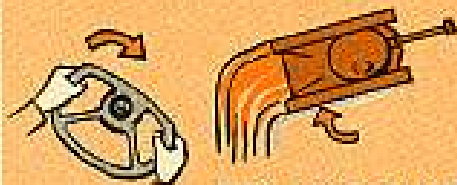

TURN WHEEL RIGHT

TO PIVOT LEFT...



LET THE ENGINE DROP TO IDLE (650 RPM) WHEN PIVOTING. THEN CONTROL YOUR TURN WITH A COMBO OF YOUR GAS PEDAL AND PRESSURE ON THE WHEEL.

Use neutral steer only when you've really got to. It's hard on the tracks 'cause it makes for extra wear on the pads...

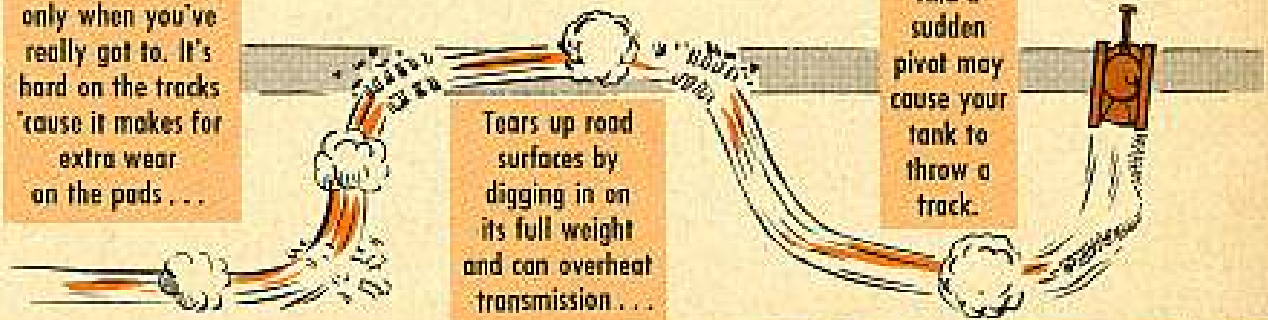

Tears up road surfaces by digging in on its full weight and can overheat transmission...

And a sudden pivot may cause your tank to throw a track.

IN NEUTRAL STEER, THE CROSS-DRIVE TRANSMISSION WILL CAUSE THE TRACK TO TURN BACKWARD WHILE THE OTHER TRACK TURNS IN THE OPPOSITE DIRECTION.

## REVERSE:



WHEN TURNING IN REVERSE RANGE, THE VEHICLE WILL STEER IN DIRECTION OPPOSITE THE MOVEMENT OF STEERING WHEEL

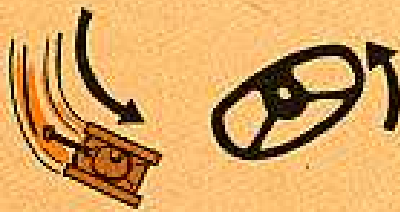

TO GO STRAIGHT BACK...  
COME TO A DEAD HALT...



'N SHIFT TO  
REVERSE.

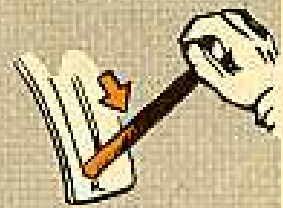

FOR RIGHT REVERSE... STOP...  
SHIFT TO REVERSE AND TURN THE  
STEERING WHEEL TO LEFT...



AND THE VEHICLE  
WILL MOVE REAR-  
WARD TO THE  
RIGHT.



FOR LEFT REVERSE... STOP...  
SHIFT TO REVERSE AND TURN THE  
STEERING WHEEL TO RIGHT...



AND THE VEHICLE  
WILL MOVE REAR-  
WARD TO THE  
LEFT.



REAR SPEEDS SHOULD NEVER GO  
ABOVE 5 MPH, AND ALWAYS HAVE  
A GROUND GUIDE, CAUSE EVEN IF  
YOU HAD EYES IN BACK OF YOUR  
HEAD YOU COULDN'T SEE WHAT'S  
BEHIND YOU.

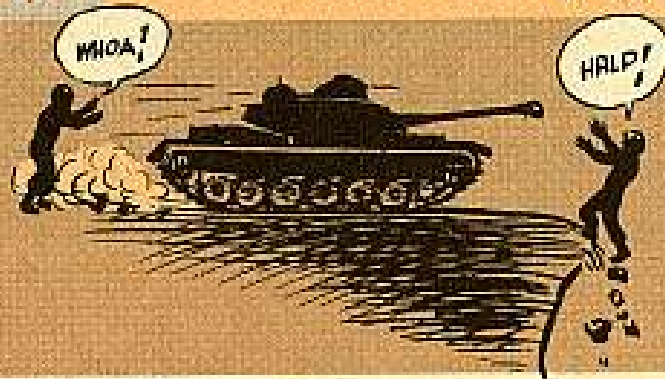

## AT-HALT CHECKS



CHECK TRACKS AND  
SUSPENSION FOR  
LOOSENESS OR BREAKS.

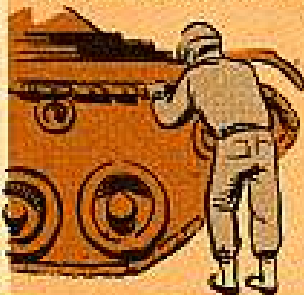

LOOK FOR LEAKS  
INSIDE AND UNDER  
THE VEHICLE



ARE YOUR OIL  
LEVELS READING  
RIGHT?

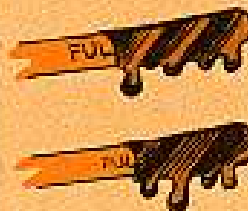

LOOK OVER ENGINE  
AND ENGINE COOLING  
FANS

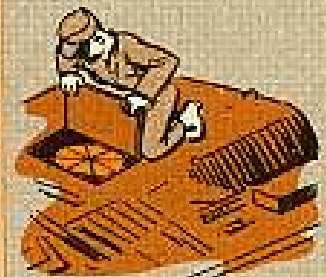

You shouldn't let it run at low idle (650 RPM). Always set throttle for a little above high idle (1000 RPM) during waiting periods. This prevents excess fouling of plugs.

# STOPPING THE ENGINE

SHIFT TO PARK.

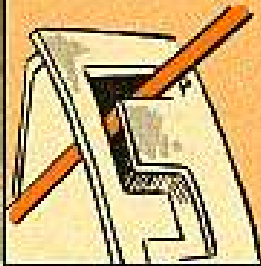

JAM ON BRAKE PEDAL TO SET PARKING BRAKE.

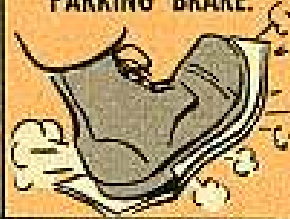

RUN ENGINE FOR 3 TO 5 MINUTES AT 1000 RPM



TO COOL OFF ENGINE.

MAKE SURE THROTTLE'S ALL THE WAY HOME.



ENGINE SHOULD DROP TO LOW IDLE (650 RPM).

PRESS AND HOLD DEGASSER (FUEL CUTOFF SWITCH)



UNTIL ENGINE STOPS

IF IT DOESN'T STOP, RELEASE DEGASSER AND TURN FUEL CONTROL VALVE TO OFF.



ENGINE SHOULD DIE OUT IN ABOUT TWO MINUTES.

**MAKE SURE ENGINE IS DEAD BEFORE FLIPPING MAGNETO SWITCH TO OFF. CAREFUL—STOPPING THE ENGINE WITH MAG SWITCH MIGHT CAUSE A BACKFIRE. NEVER DO IT.**

RADIO MAIN SWITCH OFF?

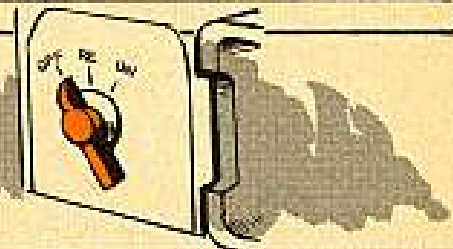

SHUT OFF ALL LOAD SWITCHES . . . TURRET POWER, VENTILATOR, FIRE CONTROL. HEATER EMERGENCY SWITCH MUST NOT BE USED TO TURN OFF PERSONNEL HEATER. THE HEATER WILL BURN OFF (PURGE) WHATEVER FUEL IT'S GOT AFTER IT'S BEEN SHUT OFF. SO DON'T THINK YOUR HEATER'S FLIPPED ITS LID. IT'S NOT A GOOD IDEA TO RUN HEATER WITHOUT ENGINE OR LI'L JOE WORKING 'CAUSE IT PULLS PLENTY POWER OFF THE BATTERY.

FLIP MASTER RELAY SWITCH OFF



... UNLESS THE RADIO OR TURRET IS TO BE USED. IN THAT CASE, POWER 'EM WITH THE AUXILIARY ENGINE.

IF TANK IS TO BE PARKED FOR ANY LENGTH OF TIME, CLOSE THE FUEL CONTROL VALVE.



# AFTER-OPERATIONS SERVICE

**OIL LEVELS**—BRING ENGINE, TRANSMISSION, AUXILIARY ENGINE AND HYDRAULIC POWER UNIT LEVELS UP TO PAR.

**CLEAN**—DIRT AND MUD FROM INSIDE AND OUTSIDE OF TANK.

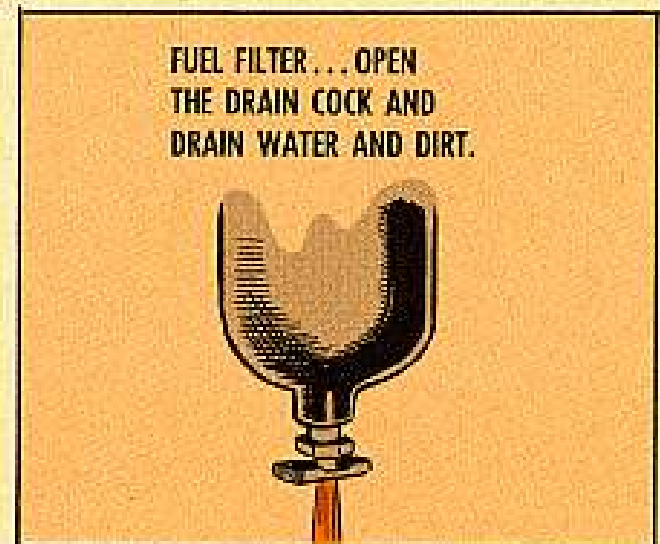
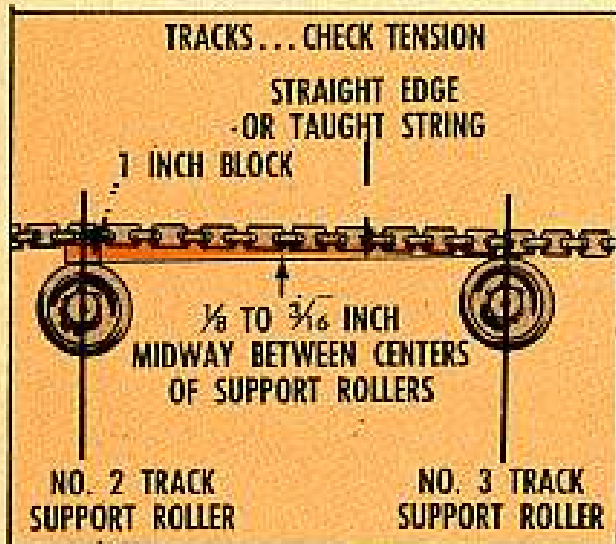

**LEAKS**—INSPECT FOR POSSIBLE ENGINE OIL, HYDRAULIC OIL OR GAS LEAKS

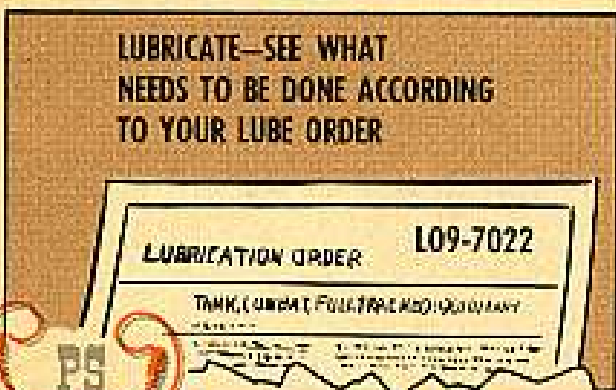
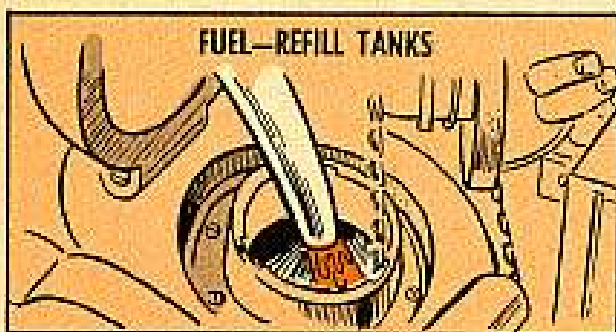

Of course, this just hits the highlights of what you should know about the M48A2. It's a back pocket reference when TM 9-7022 is not handy or someone else is using it.



# WATCH YOUR



Naturally, you watch where you put your feet when there's any chance of falling. But when doing electric welding, some people have gotten into a bind by not watching the other ground—the ground clamp from their welding machine.

Of course you know what a heat your welding current kicks up at the arc. It melts both the electrode and the base metal, and makes the weld for you.

Sometimes folks forget that this heavy current will set up the same kind of heat anywhere it arcs. So they get careless about putting the ground clamp on the job.

They'll clamp to a frame, for instance, when they're going to weld on a wheel. This means the welding current has to pass through the wheel bearings on its way back to the machine. And the bearings don't take kindly to it at all.

Even if an actual arc doesn't take place in the bearing, it's real easy for all that heavy current to get the ball or roller all hot up. Frequently so hot up that it loses its heat-treat, and eventually falls to bits.

Same thing can happen to gears in a transmission or differential. Carrying the current through one or two teeth can heat the teeth and anneal 'em, later on they snap off and louse up the deal.

One other thing: It sometimes happens that when you're using a DC welder, you'll get a nasty arc-blow, particularly if you're welding in a corner or an angle. Oftentimes you can cut this down or eliminate it by re-locating your ground—perhaps to the other side of your weld.

Other times, if you can change the polarity of your machine you can get rid of the blow. (Be sure to use the proper electrode for the reversed polarity.) But, remember, arc-blow or not, don't run that welding current through bearings or gears.

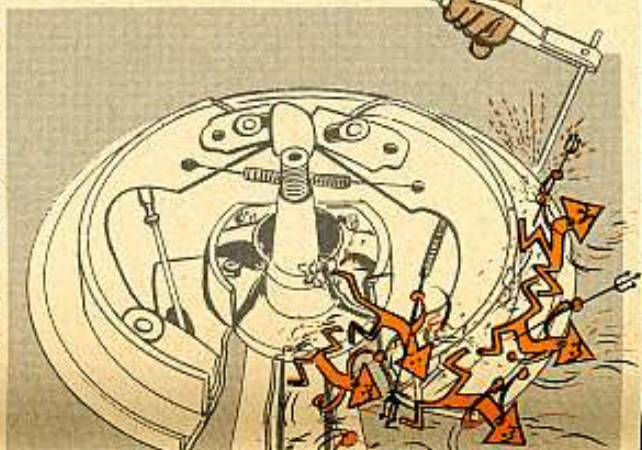

# GROUND

And never hook up so that the welding current must pass through bearings, gears or moving parts.

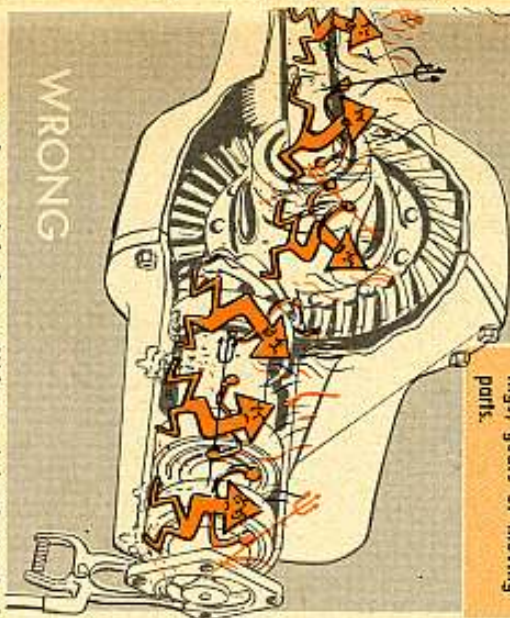

WRONG

setting—might be you'll burn right through the job when you start up again. So watch the cables for condition and tight connections, what?

Also, you know that as any conductor heats up, the resistance increases. In welding, this can trip you up if you have bad cables with broken strands, loose terminals or loose connections. Because they'll heat at the loose points while you work, and you'll probably increase your machine setting to take care of it.

Which is OK until and unless you leave the job for a while and let things cool off. Cold conductors, no resistance, high machine

RIGHT

ALWAYS ATTACH YOUR GROUND CLAMP AS CLOSE TO YOUR WELD AS POSSIBLE. Put it on the same part if you possibly can.



CLEAN OFF ANY PAINT SO YOU GET A GOOD METAL-TO-METAL CONTACT BETWEEN THE CLAMP AND THE JOB.

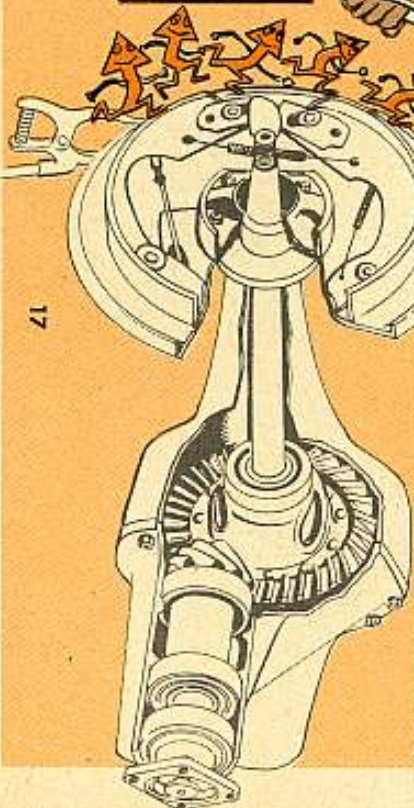

## A FEW HOT WEATHER TIPS



Here're a few extra tips for when you're running tactical wheeled vehicles in those very hot areas—

If your tactical truck has the latest gas-tank filler cap, FSN 2910-741-2761, which has an internal vent valve, keep that valve closed if you're running in a hot area where vapor lock is likely. This helps stop vapor lock from bogging you down.

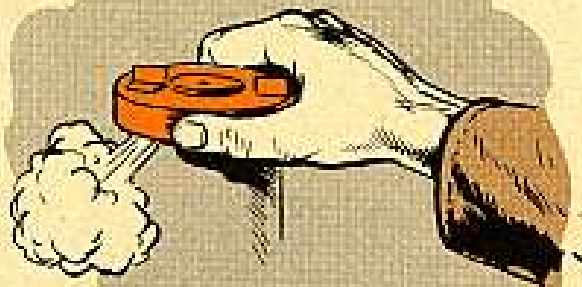

There's another way to help cure vapor lock. If it bogs you down, get some water, if there's any around, and pour it over the fuel lines and fuel pump, if the pump's mounted where you can get at it. This condenses the gasoline that has boiled or vaporized in the fuel system and caused the lock. Of course, if there's no water around, you'll have to wait for things to cool off inside that engine before you can start it.

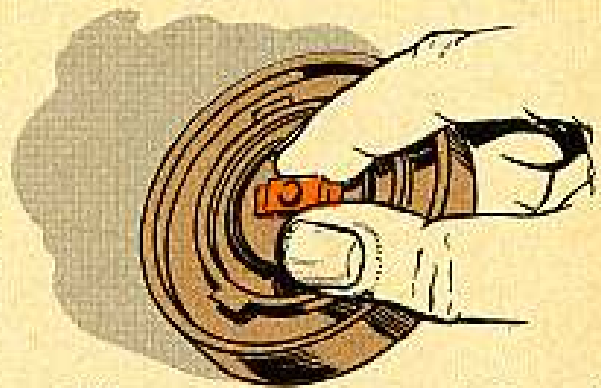

When you stop your truck for a time, make sure you open the cap one notch, relieving the pressure that builds up inside the fuel system. Careful you don't get doused with gasoline when doing this. Tighten the cap again before taking off on another run. To get the low-down on this gas-tank cap and how to use it, read over your copy of TB Ord 626 (1 Oct 57).

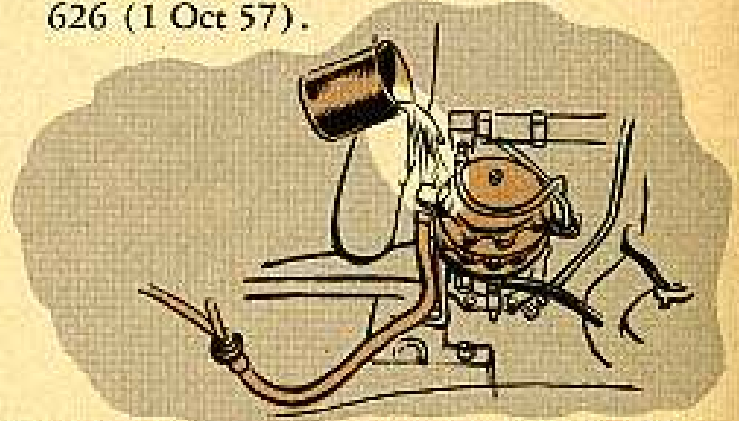

Oh, yeah—vapor lock inside your G749-series 2½-ton trucks is pretty unlikely, because it has an electric fuel pump specifically put in the gasoline tank to help prevent locking.

**NOW, TO THE COOLING SYSTEM—**

Never pour water into your truck's radiator when it's overheating—it could crack the block. Wait until the engine cools off.

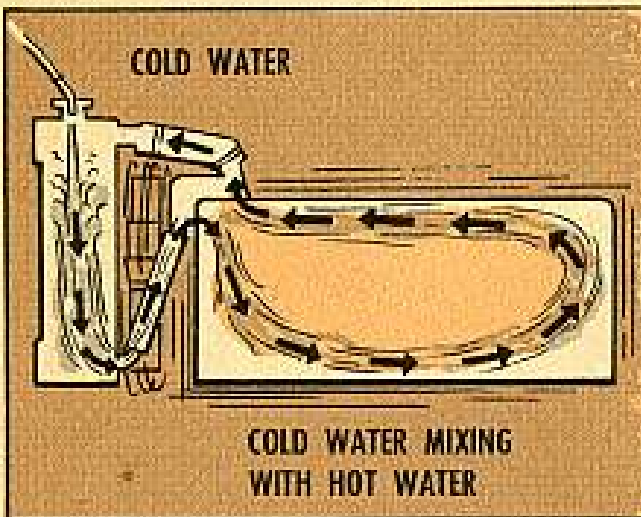
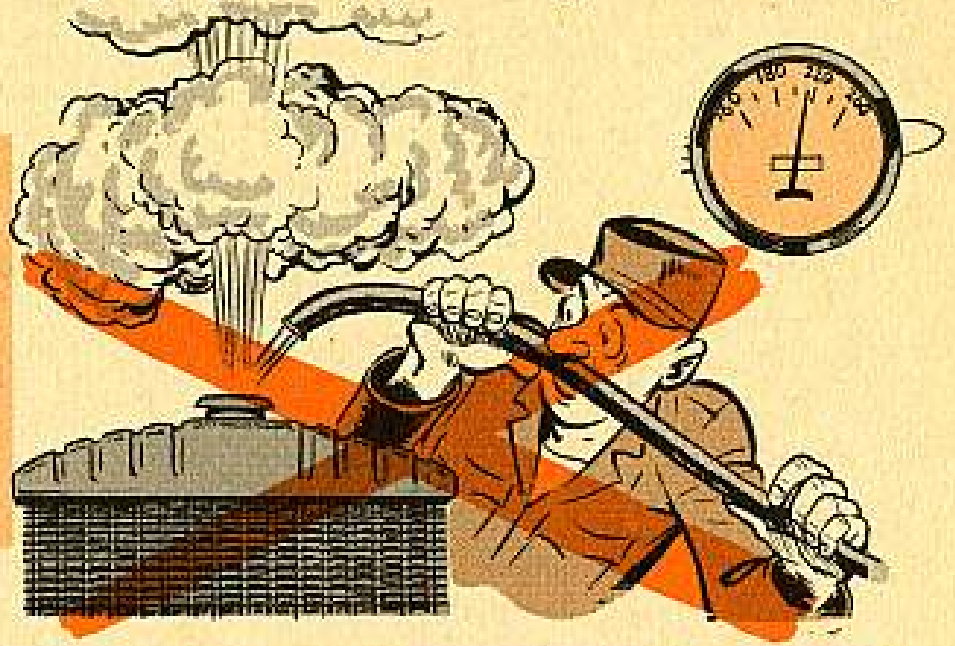

Now, when you do go to pour water in, make sure the engine's running. This lets the water pump force warm water from the block up the radiator inlet hose. The cold water you add cannot run into the hot engine, but must first pass down through the radiator, mixing with the warm water being forced up by the water pump. This means that warmer water passes into the block instead of cold. Makes things safer.

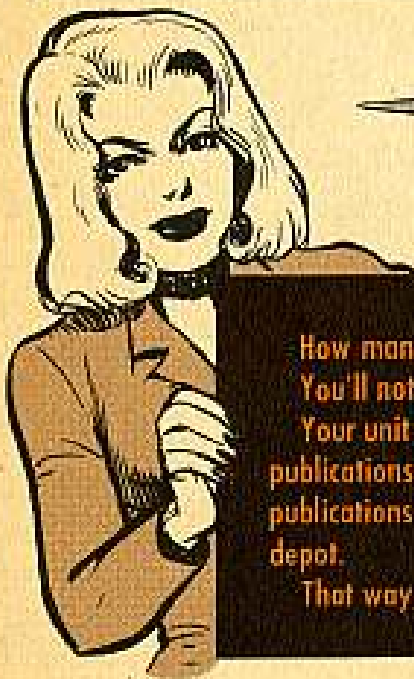

**YOUR UNIT NEED PS?**

How many do you need?  
You'll notice a little different angle on distribution of PS than you've seen on page 1. Your unit now has to make sure it lets your post or major unit publications unit (post publications) know how many copies of PS Magazine you need each month. Then, the publications people will report all the post's needs on DA Form 12 to the publications depot.  
That way, your post will get enough to pass around to all units.

# SHAPE UP YOUR TOOL KIT



Your General Mechanic's Tool Kit now has a new look. The revised version of this kit has a few new tools and has dropped some of the old ones. Now you make your tool check according to SM 9-4-5180-J10-4 (18 June 58), which supersedes Ord 6 SNL J10, Section 4 (Oct 50).

Just so you'll be up-to-date on knowing what the new tools and nomenclatures look like, here's a rundown on the latest

## Tool Kit, General Mechanics, FSN 5180-754-0641

The names and numbers are fresh out of the latest supply manuals.

BAR, PRY: rolling hd,  
½ in dia, 16 in lg.



FSN 5120-224-1389

BIT, SCREWDRIVER: fl  
tip, ½ in sq-drive, ¼  
in blade.

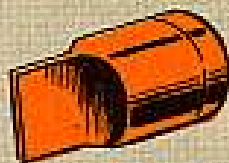

FSN 5120-223-6986

BIT, SCREWDRIVER: fl  
tip, ¾ in w, female sq-  
drive shk, ½ in sq-drive  
1½ in lg overall.

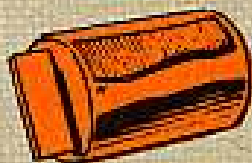

FSN 5120-277-3600

BOX, TOOL: S, loose,  
tray, approx 7½ in x  
8½ in x 21 in.

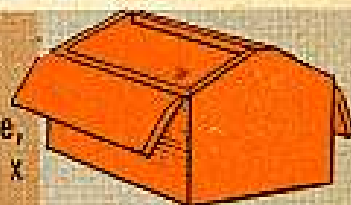

FSN 5140-357-5483

BRUSH, PAINT: oval,  
hog bristle, w/chisel  
edge, 1¾ in w, 1¼ in  
thk, 2¼ in min ex-  
posed lg.

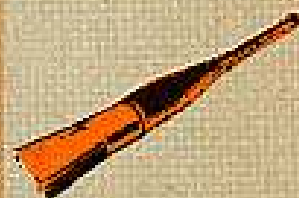

FSN 8020-239-0959 (ENG)

CHISEL, COLD, HAND:  
½ in cut, 6 in lg.

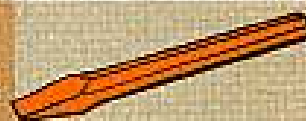

FSN 5110-186-7107

CHISEL, COLD, HAND: 3/4 in w cut, 7 in lg overall.



**FSN 5110-236-3272**

DRIFT: S, rd, stght, w/ br tip, 3/4 in dia, 10 in lg.

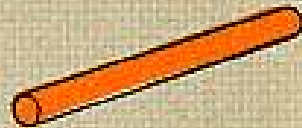

**FSN 5120-754-0840**

FILE, HAND: American patt, fl type, dble cut, sm faces, sgle-cut, sm edges, 10 in heel to pt.

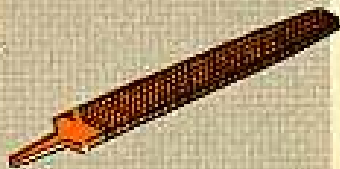

**FSN 5110-249-2850**

FILE, HAND: American patt, rd, dble cut, bastard cut, 8 in heel to pt.



**FSN 5110-234-6551**

FILE, HAND: sw-patt, 3 sq, 6 in heel to pt, faces no 4 dble cut, edges no 4 sgle-cut.

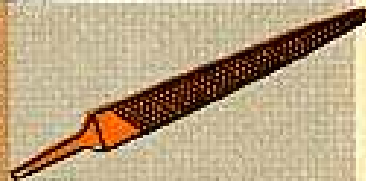

**FSN 5110-595-8301**

GAGE, GAP SETTING: 8 wires, 0.010 in, 0.012 in, 0.015 in, 0.018 in, 0.020 in, 0.022 in, 0.025 in, & 0.030 in, angular shaped folding type feelers, w/lkg tension device, gap adj tool & mtl holder.

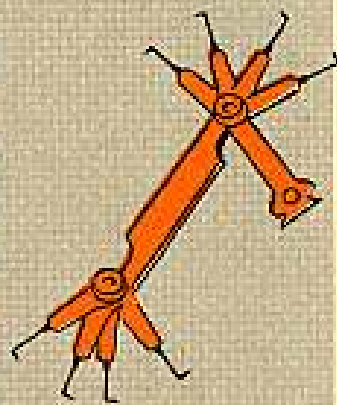

**FSN 5210-273-1935**

GAGE, THICKNESS: 1 leaf gp, English system, 26 tapd leaves, tempered, 3 in lg w/case.

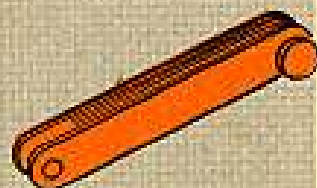

**FSN 5210-221-1999**

HAMMER, HAND: machinist's ball peen, 1/2 lb.



**FSN 5120-242-3913**

HAMMER, HAND: machinist's ball peen, 2 lb.



**FSN 5120-224-4047**

HANDLE, FILE, WOOD: med size, 1 1/4 in dia of hand grip.



**FSN 5110-263-0349**

KNIFE, PUTTY: 1 1/4 in w flex blade.



**FSN 5120-221-1536 (ENG)**

PADLOCK: pintumbler mech, br case, cd fin shackle, 1 3/4 in, w/o clevis, keyed individually, w/2 keys.

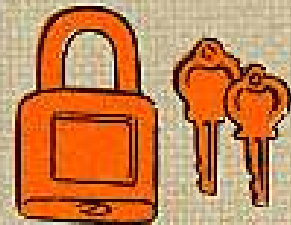

**FSN 5340-205-5517 (ENG)**

PLIERS, SLIP JOINT: stght nose, comb, w/ cutter, 8 in lg.



**FSN 5120-223-7397**

PLIERS: side-cutt, lg rd nose w/cutter, 6 in lg.



**FSN 5120-247-5177**

PLIERS, DIAGONAL CUTTING: 6 in lg.



**FSN 5110-250-8253**

PUNCH, CENTER, SOLID: 1/8 in nom dia at top of tapd pt, 3/8 in nom dia of stk, 4 in nom lg overall.



**FSN 5120-293-3509**

PUNCH, DRIFT:  $\frac{3}{8}$  in dia of pt,  $\frac{3}{8}$  in nom dia of stk, 9 in min to 10 in max overall lg.



**FSN 5120-293-0448**

PUNCH, DRIVE PIN: tapd type,  $1\frac{1}{2}$  in nom taper lg,  $\frac{1}{8}$  in dia of pt.



**FSN 5120-293-3377**

PUNCH, DRIVE PIN: hardened 50-55 Rockwell "C" scale, 1 in nom lg of pt,  $\frac{1}{4}$  in dia of pt.



**FSN 5120-595-9521**

PUNCH, DRIVE PIN: stght type,  $\frac{3}{8}$  in dia pt, 1 in lg pt.



**FSN 5120-273-0001**

RULE, STEEL, MACHINIST'S: 6 in lg,  $\frac{1}{2}$  in w, 0.031 in thk, smallest unit of grad for each grad edge,  $\frac{1}{4}$  in,  $\frac{1}{8}$  in,  $\frac{1}{16}$  in,  $\frac{1}{32}$  in, rh reading.



**FSN 5210-234-5223**

SCREWDRIVER, FLAT TIP: plastic hdl, flared tip,  $\frac{1}{4}$  in w tip,  $1\frac{1}{2}$  in lg blade.



**FSN 5120-596-8502**

SCREWDRIVER, FLAT TIP: mtl w/wood inserts hdl, flared tip,  $\frac{3}{8}$  in w tip, 6 in lg blade.



**FSN 5120-227-7349**

SCREWDRIVER, FLAT TIP: wood hdl,  $\frac{1}{4}$  in w flared tip, 4 in lg blade.



**FSN 5120-277-9491**

SCREWDRIVER, OFFSET: opposite offset, opposite ends, ea offset tipped, fl tip parallel to longitudinal axis of body, fl tip 90 deg angle to longitudinal axis of body, or fl tip 45 deg angle to longitudinal axis of body,  $\frac{3}{8}$  in w, 6 in lg overall.

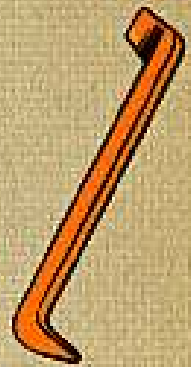

**FSN 5120-240-5232**

SCREWDRIVER, CROSS TIP: recessed screw, Phillips type, common, slow burning plastic hdl, 3 in blade, no 1 tip.



**FSN 5120-240-8716**

SCREWDRIVER, CROSS TIP: recessed screw, Phillips type, common, slow burning plastic hdl, 4 in blade, no 2 tip.



**FSN 5120-234-8913**

SCREWDRIVER, CROSS TIP: recessed screw, Phillips type, common, slow burning plastic hdl, 6 in blade, no 3 tip.

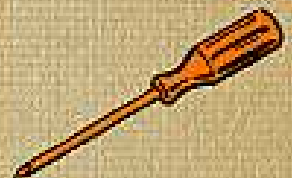

**FSN 5120-234-8912**

SHEARS, METAL CUTTING, HAND: duckbill comb patt, 7 in lg overall.



**FSN 5110-221-1085**

SOCKET, SOCKET WRENCH: deep style,  $\frac{1}{2}$  in sq drive, 12 point,  $\frac{1}{4}$  in wrench opening.

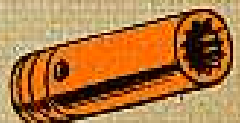

**FSN 5120-243-7345**

SOCKET, SOCKET  
WRENCH: 1/2 in sq drive,  
12 point, 1 1/8 in opng.



FSN 5120-189-7913

SOCKET, SOCKET  
WRENCH: 1/2 in sq drive,  
12 point, 1 1/8 in opng.



FSN 5120-189-7914



WRENCH, OPEN END,  
ADJUSTABLE: sgte open  
end, 1/8 in jaw opng, 8  
in lg.



FSN 5120-240-5328

WRENCH: bx, dble-hd,  
12 pt, half-moon, 3/8 in  
& 3/8 in opng.



FSN 5120-313-9495

WRENCH, BOX: dble-off-  
set, dble-hd type, 12 pt,  
45 deg offset, 3/8 in &  
3/8 in opng, 4 in nom lg.



FSN 5120-184-8679

WRENCH, BOX: dble-off-  
set, dble-hd type, 12 pt,  
45 deg offset, 1/2 in &  
3/8 in opng, 4 3/4 in nom  
lg overall.

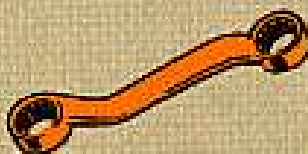

FSN 5120-224-3154

WRENCH, BOX: dble-hd  
type, 12 pt, 45 deg off-  
set, 5/8 in & 3/8 in opng,  
6 in nom lg overall.

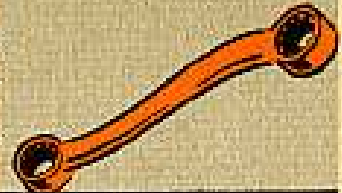

FSN 5120-224-3138

WRENCH, OPEN END,  
FIXED: dble open end,  
15 deg angle, spear-hd,  
alloy-S, 3/8 in & 3/8 in  
opng.

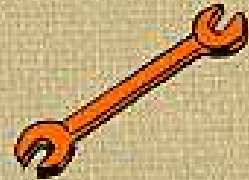

FSN 5120-277-2342

WRENCH, OPEN END,  
FIXED: dble-hd, 15 deg  
angle, spear-hd, alloy-S,  
1/2 in & 3/8 in opng, 1/8  
in thk hd, 5 1/2 in lg  
overall.

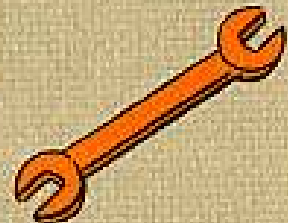

FSN 5120-187-7124

WRENCH, OPEN END,  
FIXED: dble-hd, 15 deg  
angle, spear-hd, alloy-S,  
5/8 in & 1/8 in opng, 7  
in lg overall, 2/8 in thk  
of hd.

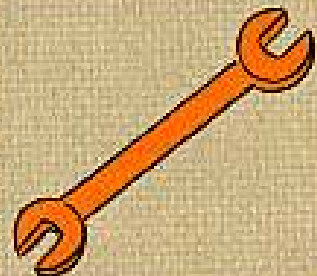

FSN 5120-277-8301



WRENCH, SPANNER:  
adjustable hook, 3/4 to  
2 in circle dia, 1/2 in  
thk of hook.



FSN 5120-288-6468

These tools were formerly listed as individual items in your tool kit.

WRENCH SET, SOCKET: 1/2 in w across flats sq drive, 12 point, handle and/or attachment furnished w/case.

FSN 5120-289-8665

EXTENSION, 1/2 in sq-drive, 5 in lg.



FSN 5120-243-7326

EXTENSION, 1/2 in sq-drive, 10 in lg.



FSN 5120-227-8074

HANDLE, brace speeder type, 1/2 in sq-drive, 18 in lg.



FSN 5120-230-6364

HANDLE, hinged, 1/2 in sq. drive, 12 1/4 in nom lg overall.



FSN 5120-221-7958

HANDLE, rvrs rtc type, 1/2 in size drive end, 9 1/2 in nom lg overall.



FSN 5120-230-6385

UNIVERSAL JOINT, 1/2 in sq-drive.



FSN 5120-269-7971

SOCKET, SOCKET WRENCH: 1/2 in sq-drive, 12 pt

|               |  |                   |
|---------------|--|-------------------|
| 3/8 in opng   |  | FSN 5120-189-7924 |
| 1/2 in opng   |  | FSN 5120-237-0984 |
| 5/8 in opng   |  | FSN 5120-189-7932 |
| 1 1/2 in opng |  | FSN 5120-239-0019 |
| 5/8 in opng   |  | FSN 5120-189-7946 |
| 1 1/4 in opng |  | FSN 5120-235-5870 |
| 3/4 in opng   |  | FSN 5120-189-7985 |
| 7/8 in opng   |  | FSN 5120-189-7915 |
| 1 3/8 in opng |  | FSN 5120-189-7933 |
| 7/8 in opng   |  | FSN 5120-189-7934 |
| 1 1/2 in opng |  | FSN 5120-189-7935 |
| 1 in opng     |  | FSN 5120-189-7927 |

\*WRENCH SET, comb, box and open end, angle and offset 15 deg, dble-hex, alloy-S, range 3/8 to 1 in, set of 11 wrenches, in leatherette roll. This set consists of roll and wrenches below:

FSN 5120-357-8411

\*This takes the place of Wrench Set, Socket FSN 5120-203-9573 listed in SM9-4-5180-J10-4.

1 ROLL, tool, leatherette or canvas, empty, No. of pockets 11.

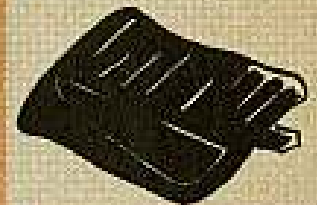

FSN 5140-322-6009



1 WRENCH, BOX AND OPEN END, COMB: 12 pt, 15° angle and offset.

|          |  |                   |
|----------|--|-------------------|
| 3/8 in   |  | FSN 5120-228-9504 |
| 1/2 in   |  | FSN 5120-228-9505 |
| 5/8 in   |  | FSN 5120-228-9506 |
| 3/4 in   |  | FSN 5120-228-9507 |
| 7/8 in   |  | FSN 5120-228-9508 |
| 1 1/4 in |  | FSN 5120-228-9509 |
| 1 1/2 in |  | FSN 5120-228-9510 |
| 1 3/8 in |  | FSN 5120-228-9511 |
| 1 1/2 in |  | FSN 5120-228-9512 |
| 1 3/8 in |  | FSN 5120-228-9513 |
| 1 in     |  | FSN 5120-228-9514 |



# Connie Rodd's

"SHORT 'N SWEET DEPT"

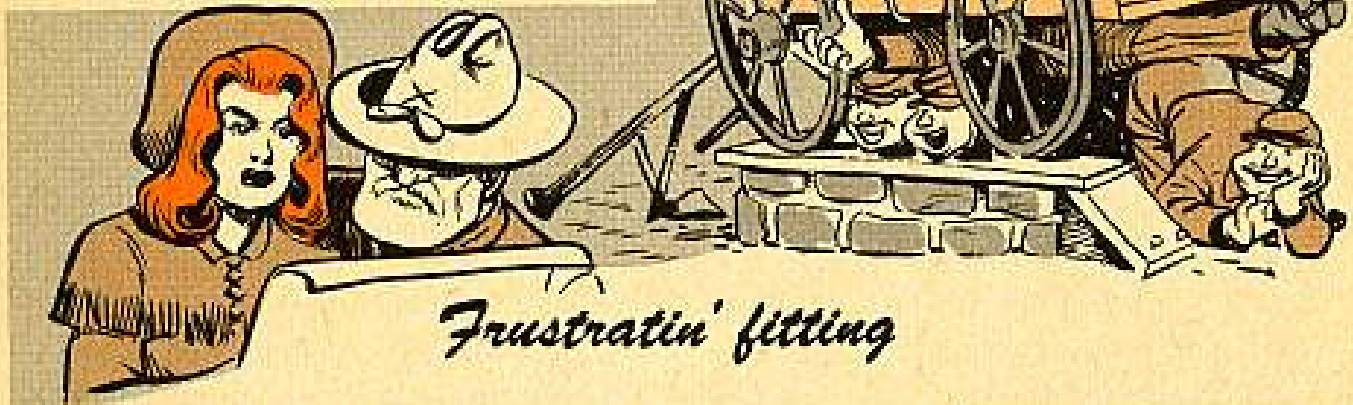

## *Frustratin' fitting*

Having trouble greasin' the sprocket drive shaft U-joints with the straight lube fitting found on the inner (in-board) side of the yoke on the M56 "SPAT"?

A grease gun just can't be used with the straight fitting in that joint. So put in a fitting that'll do the trick. Ask for Fitting, Lubrication, 45°, 1/4-28 FSN 4730-172-0041 (ORD). All vehicles after serial number 277 have the 45° lube fitting put in at the factory.

If yours is one of the early birds...just put the 45'er in so you can get the grease gun on 'er.

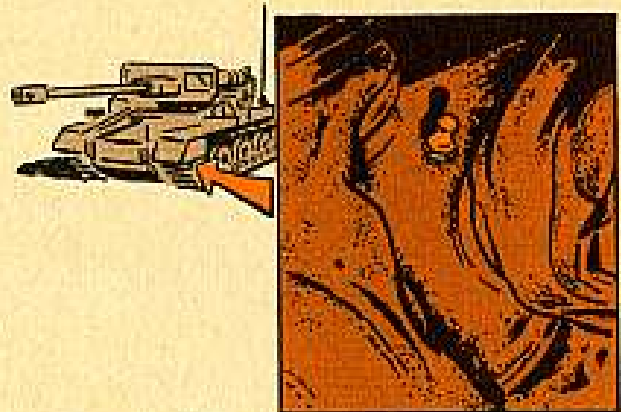

## *Backfield in motion*

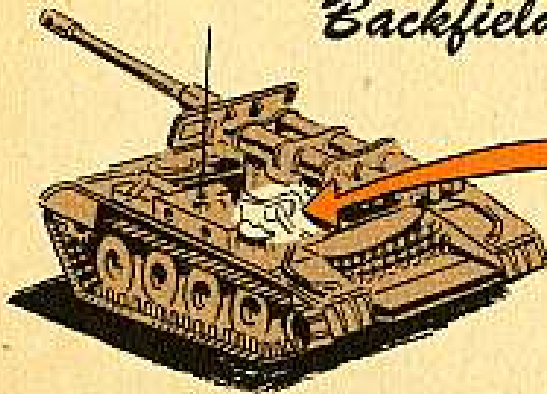

Gets kind of uncomfortable when your driver's seat backrest goes into extra motions while you run your M56 self-propelled 90-mm gun ("SPAT") downfield. You can stop the vibration from loosening the backrest by putting on a lockwasher...like the new models are getting. It'll hold better than a grade-A girdle.



## *It's an improvement*

Y'may have noticed that once the paper packets in your old ABC-M3 food testing and screening kit got exposed to moisture, it was curtains for the chemicals in the packets. Dampness had a way of sneaking into the packets, making the chemicals inside useless.

You won't have to fret about that any longer, though. In the repackaged M3 food testing kits FSN 6665-171-9745 (Chem) you'll be getting soon, all



TEST PAPERS REDUCED  
FROM 12 TO 9

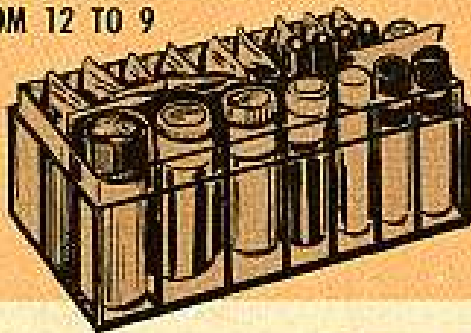

of the paper packets with chemicals in 'em have gone modern—the chemicals are now packaged in glass and polyethylene tubes. Keeps 'em pure and dry.

You'll see there's more room in the kit, too, 'cause the number of test papers used with the chemicals has been reduced from 12 to 9.

## *TD-18 tractor pub*

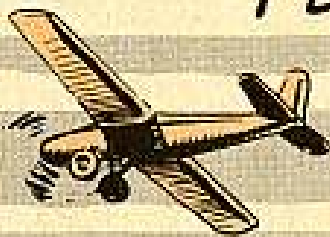

Ho there! You guys with the Model TD-18 International tractor, 182 series, oughta be interested in the manufacturer's pub you can get through your normal Engineer repair parts channels.

Manufacturer's manual No. 7610-C-1-0854 covers operation, 1st and 2d echelon PM, plus an organizational parts list.

(Manufacturer's Pub No. 7610-C-1-0905, the service manual for the tractor, diesel engine and fuel injection system, is for 3rd, 4th, and 5th echelon people.)



## Cry danger

Would you walk into a poison gas chamber without a gas mask? You'd say that would be kinda stupid, wouldn't you?

Well, some of your combat vehicle buddies are taking the same kind of chances whenever they idle their main or auxiliary engines without the right precautions.

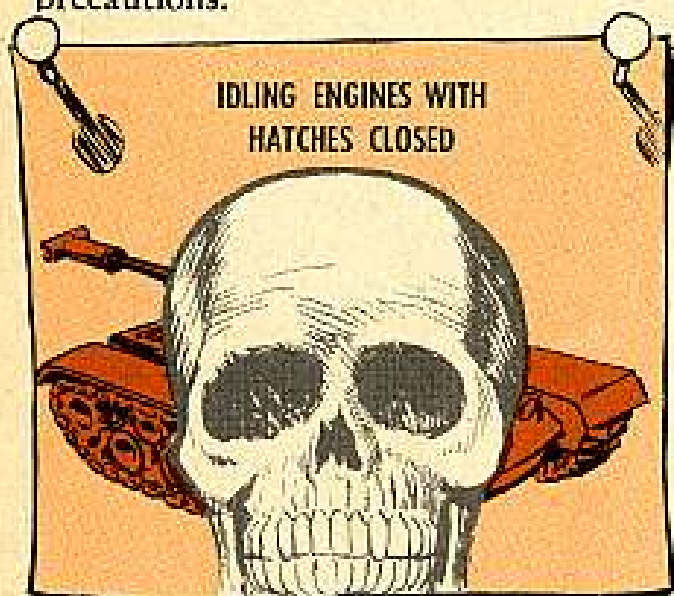

One way to get a quick return on your GI insurance policy, f'rinstance, is to warm up your engines in cold weather with all the hatches or doors closed and the ventilation blower OFF.

It's okay to operate the engine with the ventilation blower OFF—provided all the hatch doors are open and the vehicle is facing so that the wind can carry the exhaust fumes away from the crew compartment.

If your vehicle can't be positioned so that the wind will carry the fumes away, make darn sure the turret ventilation blower is ON—like it says in TB Ord 2300-10/4 (2 Jul 58), "All Combat Vehicles: Precautions Against Exhaust Fumes."

Even without an ill wind you can run into trouble by forgetting to replace access plates and panels before starting up your engines. When your hatches and doors are closed, there's a chance you'll get a sort of reverse air conditioning, keeping the fumes in the vehicle—instead of drawing 'em outside. So, always put your access or cover plates back when you're finished with a maintenance or repair job. These plates help direct your vehicle's exhaust air flow.

You also want to be alert for funny smells in the driver's compartment. Like a gassy smell. You might have a break in the exhaust system somewhere. In that case, knock those engines off immediately—if not sooner—and investigate. But be sure there's always somebody else around to come arunnin' in case something goes wrong.

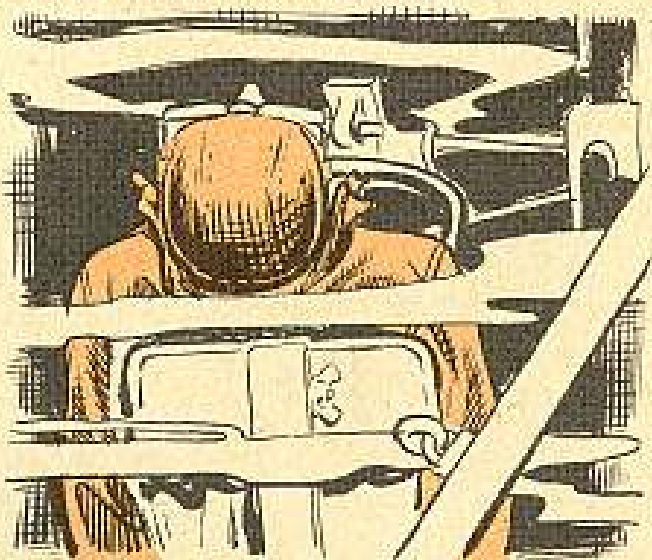

Silence is not golden when it comes to operating combat vehicle engines. Your best bet is the "buddy" system. Remember, exhaust fumes can not only lay you out flat, they can keep you that way permanently.

## Need spacers?

Best you be checkin' out those Nike-Ajax and Nike-Hercules trailers (those with air-over-hydraulic brakes).

Could find the emergency valve elbow, into which the emergency inlet line hooks, bumps the lube fitting on top of the outer yoke of the trailer front suspension. This happens when the drawbar is dropped down. Raises the devil with the elbow and snaps it clean off.

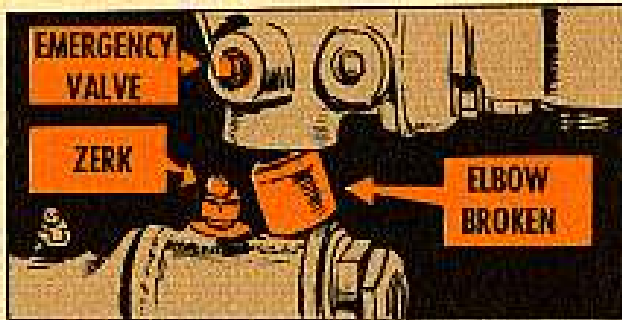

There should be about  $\frac{1}{2}$  inch lee-way twixt the lower edge of the elbow and the top of the lube fitting, but this could vary somewhat. If there's clearance, you've got no problem. But if you have no clearance then the air tank gets a shimming job—done with two home-made spacers.

Here's the way to make the spacers.

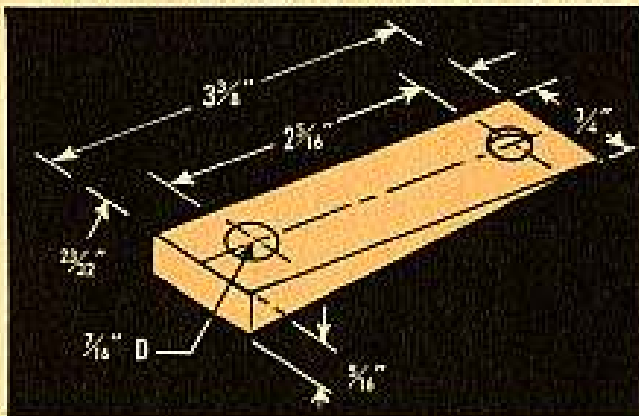

If no scrap bar stock is available, then try supply for Steel, Mild Carbon, (SAE WD 1020) Bar, Flat,  $\frac{5}{16} \times 1\frac{1}{2}$  inches, FSN 9510-596-2285.



Now the air tank mounting bolts hafta be removed so the spacers can be shoved in place. They go between the

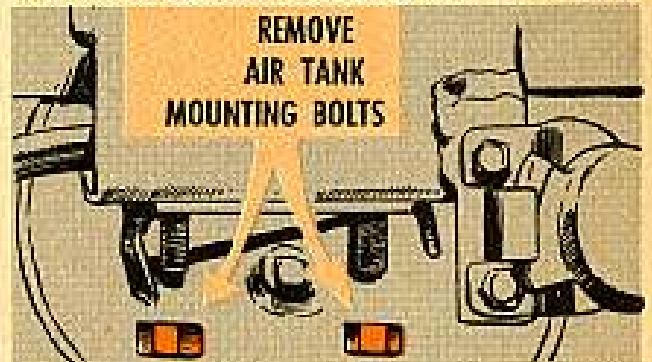

brackets welded to the drawbar and the brackets on the tank—make sure the thick end of the spacer faces the lunette eye. This way the elbow is raised higher so it misses the fitting.



When it comes to hooking them up again, the two front mounting bolts will hafta be swapped for new ones. Get supply to give you Bolt, Machine, Hex-Hd, Low Carbon-S, Cd or Zn pltd,  $\frac{3}{8}$ -24NF-2x1. These bolts are long enough to make up for the difference taken up by the spacer. Of course, you've gotta keep the nuts and washers, so you can reuse 'em.

If you want more details, see MWO 9-2330-212-20/5.

# JOE'S DOPE

## WHAT'S A DIRECTIVE?

**OBJECTIVE:** The town.  
**ORDER OF  
THE DAY:** Perform  
routine  
maintenance  
and march when  
ready.



**REPORT:** All services performing smoothly at staff level ...



... trouble at company level

**PROBLEM:** Procedure of before-operation maintenance

YOU MEN READY FOR FINAL INSPECTION?

WELL, ER- WE'RE HAVIN' SOME LITTLE DIFFICULTY, SARGE!



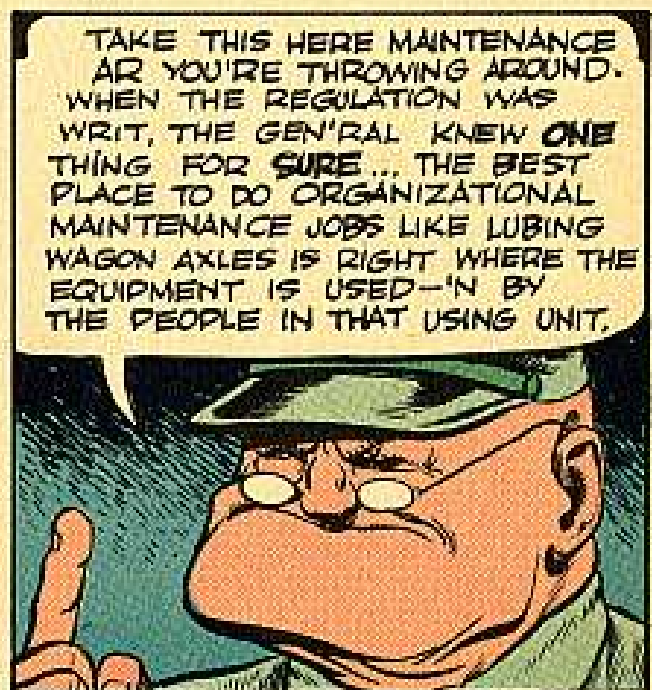
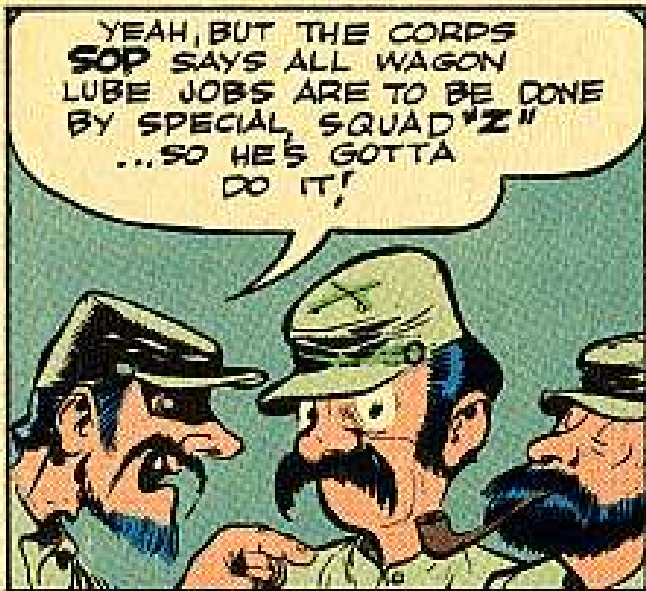

BUT THEY DID NOT SAY WHO IN THE USING UNIT'S GOTTA DO IT. THEY KNOW THAT THE ARMY'S USING UNITS HAVE TO MAKE UP THEIR OWN SOP'S (STANDING OPERATING PROCEDURES) CAUSE...



IT'S TOUGH FOR AN ARMY-WIDE DIRECTIVE TO COVER EVERY LOCAL SITUATION COMPLETELY. THE ARMY'S SPREAD OUT OVER TOO MANY DIFFERENT AREAS...



Like with a mountain outfit!

...or a desert outfit—

WHICH CAUSE DIFFERENT PROBLEMS.

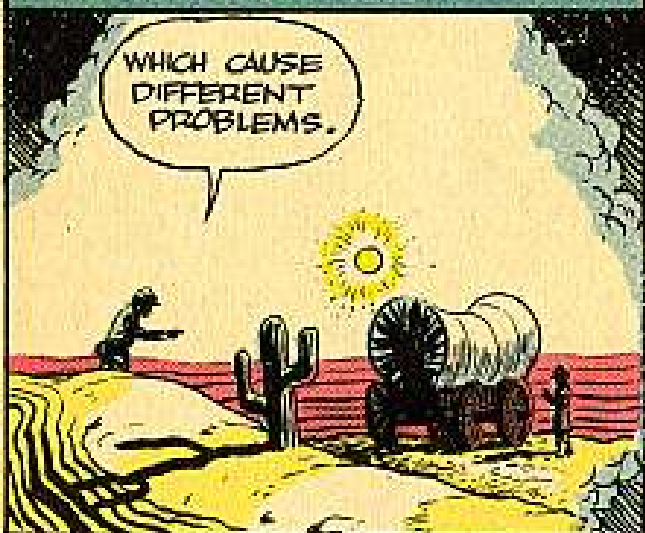

ANY OUTFIT... OURS INCLUDED... HAS TO HAVE LOCAL SOP'S TO FIT OUR OWN NEEDS. RIGHT NOW OUR LOCAL CONDITIONS REQUIRE THIS OUTFIT TO HAVE THE WAGONS LUBED BY A SPECIAL CREW... SQUAD "Z" —SO YOU'RE IT.



OF COURSE, MAKING UP A LOCAL SOP DOESN'T GIVE ANYBODY THE RIGHT TO CANT CROSS WISE TO ARMY POLICY.

BUT THEN WHAT'S ARMY POLICY, ANYHOW?



ARMY POLICY IS LAID OUT IN THE FORM OF AN AR... THIS IS A BASIC GUIDE WHICH EVERYONE FOLLOWS AT LOWER ECHELONS AND USES TO WORK OUT A LOCAL SYSTEM THAT SERVES THE SITUATION BEST.

THIS PINUP SORTA SUMS IT UP!



**Joe's**

# Dope Sheet

SUITORS WILL  
LEAVE PREMISES  
at  
reasonable hours  
— AR 385-10

Yes, the AR sets policy...true!!  
It's a guide for the job you must do.  
The details...(S.O.P.)  
Are then added...you see!  
At the level that's closest to you!

S.O.P.  
Suitors with Underlined  
Intentions Will leave  
at 10 p.m. sharp



WE HAVE THE WORLD'S BEST EQUIPMENT

...*Take care of it*



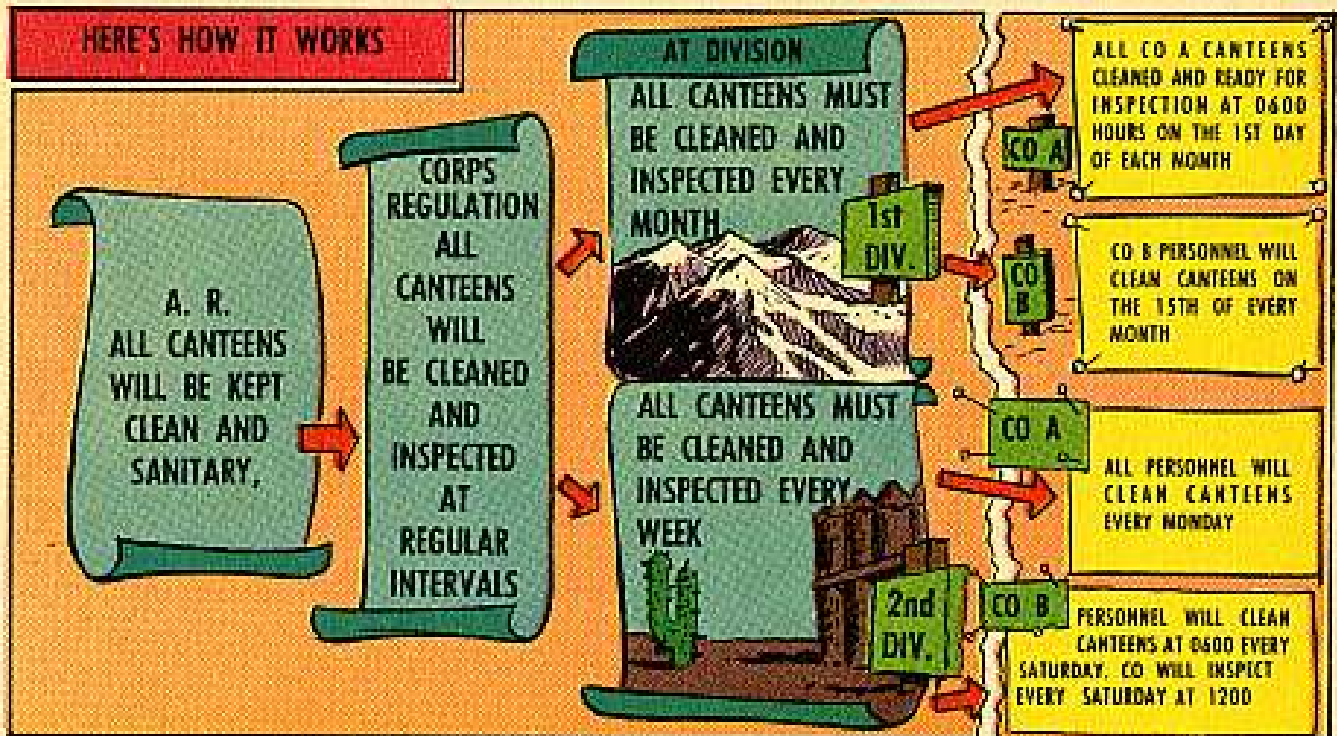
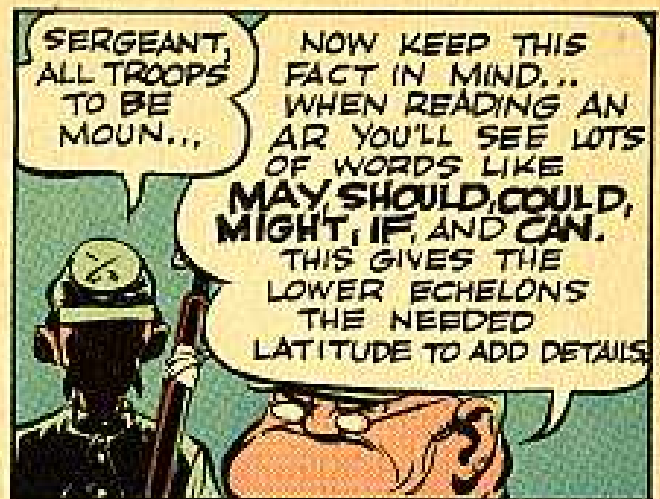

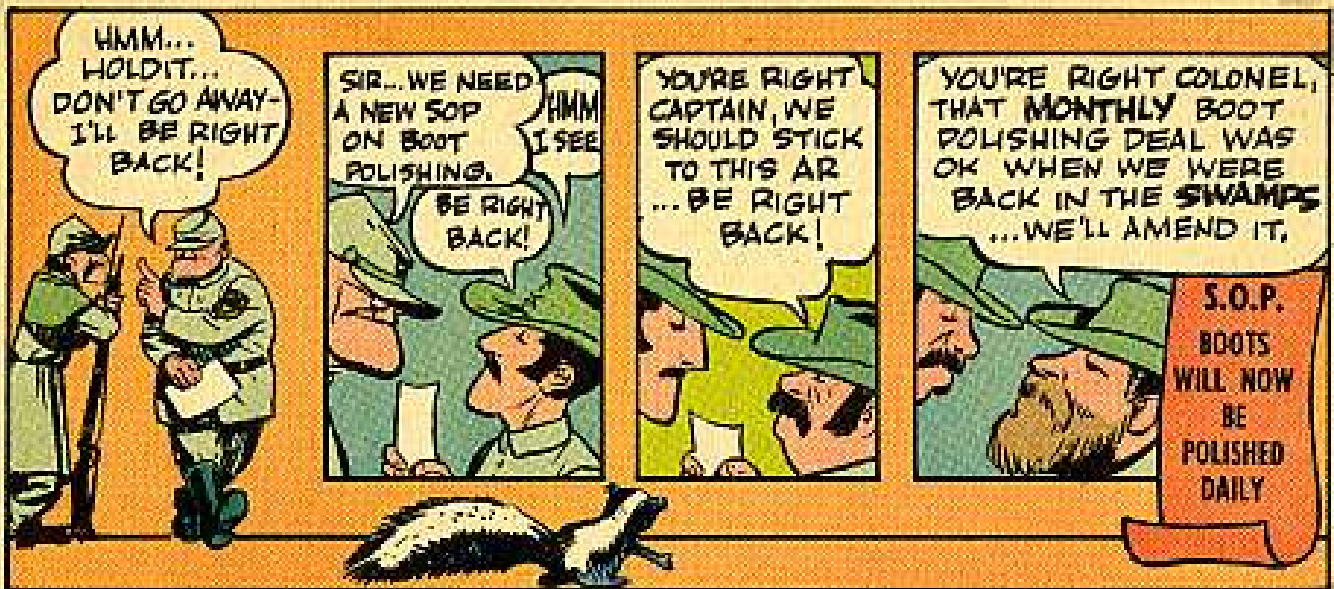

HMM...  
HOLD IT...  
DON'T GO AWAY-  
I'LL BE RIGHT  
BACK!

SIR... WE NEED  
A NEW SOP  
ON BOOT  
POLISHING.  
HMM I SEE  
BE RIGHT  
BACK!

YOU'RE RIGHT  
CAPTAIN, WE  
SHOULD STICK  
TO THIS AR  
... BE RIGHT  
BACK!

YOU'RE RIGHT COLONEL,  
THAT MONTHLY BOOT  
POLISHING DEAL WAS  
OK WHEN WE WERE  
BACK IN THE SWAMPS  
... WE'LL AMEND IT,

**S.O.P.**  
BOOTS  
WILL NOW  
BE  
POLISHED  
DAILY



OKAY... THE S.O.P. IS  
HEREBY AMENDED  
TO PROVIDE FOR DAILY  
POLISHING OF BOOTS BY  
ALL PERSONNEL!



GIT GOIN'  
BOY... START  
POLISHIN'!

I AIN'T  
GONNA CAUSE  
THE AR SAYS  
SHOULD BUT IT  
DOESN'T SAY  
MUST HAR, HAR...  
PREETY SHREWD, HUH?



B'DAY  
PASS  
VOID

YEH,  
SHREWD

NATURALLY  
THE MAN  
WHO SIGNED  
THE S.O.P.  
HAS TO  
BACK YOU  
UP!



BUT YOU CAN AVOID LOTS  
OF TROUBLE IF YOU DON'T  
TRY TO READ THINGS INTO  
THE AR'S... LET THE PEOPLE  
WHO MAKE SOP'S WORRY  
ABOUT THE "DEEPER  
MEANINGS."



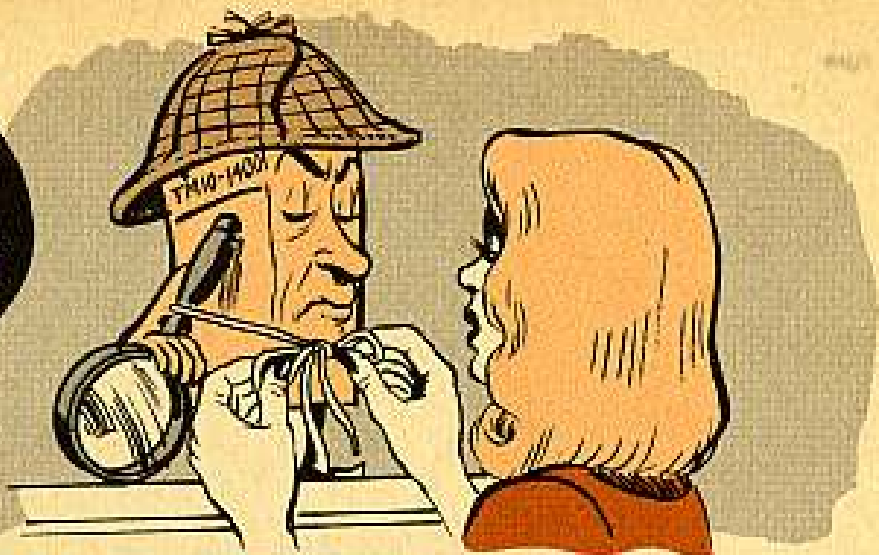
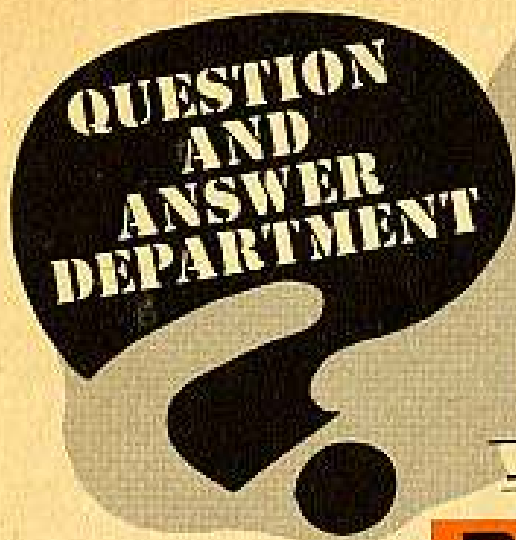

## PM PLOT

Dear Connie,

Where can I get a roundup on just how to plan maintenance and care for some of this special Quartermaster equipment?

Cpl W. D. S.

Dear Cpl W. D. S.,

The ink's almost wet, yet. On TM 10-1400—first edition of a new PM "bible" for QM units.

The plot is simple but true: Good organizational preventive maintenance on Quartermaster special purpose vehicles and equipment means a happy ending for the whole cast of characters. That includes the operator, inspector and CO.

Some of the other "characters" who appear are trailers and attachments plus mobile laundry, bakery, bath, clothing, textile and shoe repair machines.

Not to mention refrigeration and portable gasoline dispensing equipment.

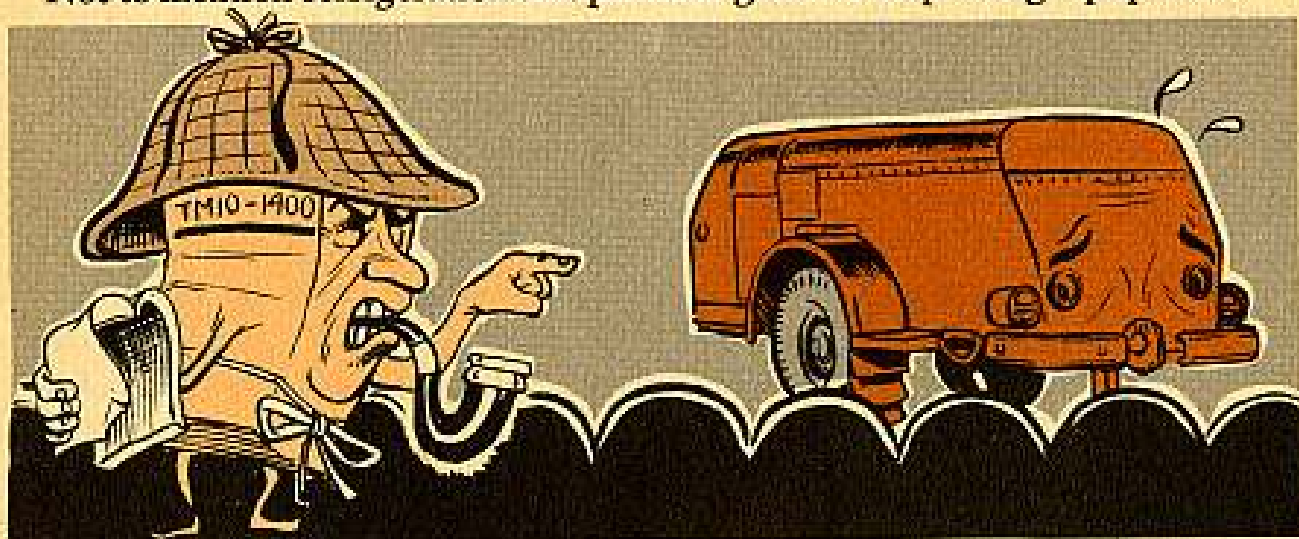

And TM 10-1400 wraps up the PM Story on QM SPV with short chapters on organizational responsibility, operator preventive maintenance services (first echelon) and inspection and organizational preventive maintenance services.



Connie

## TAIL EXTENDER

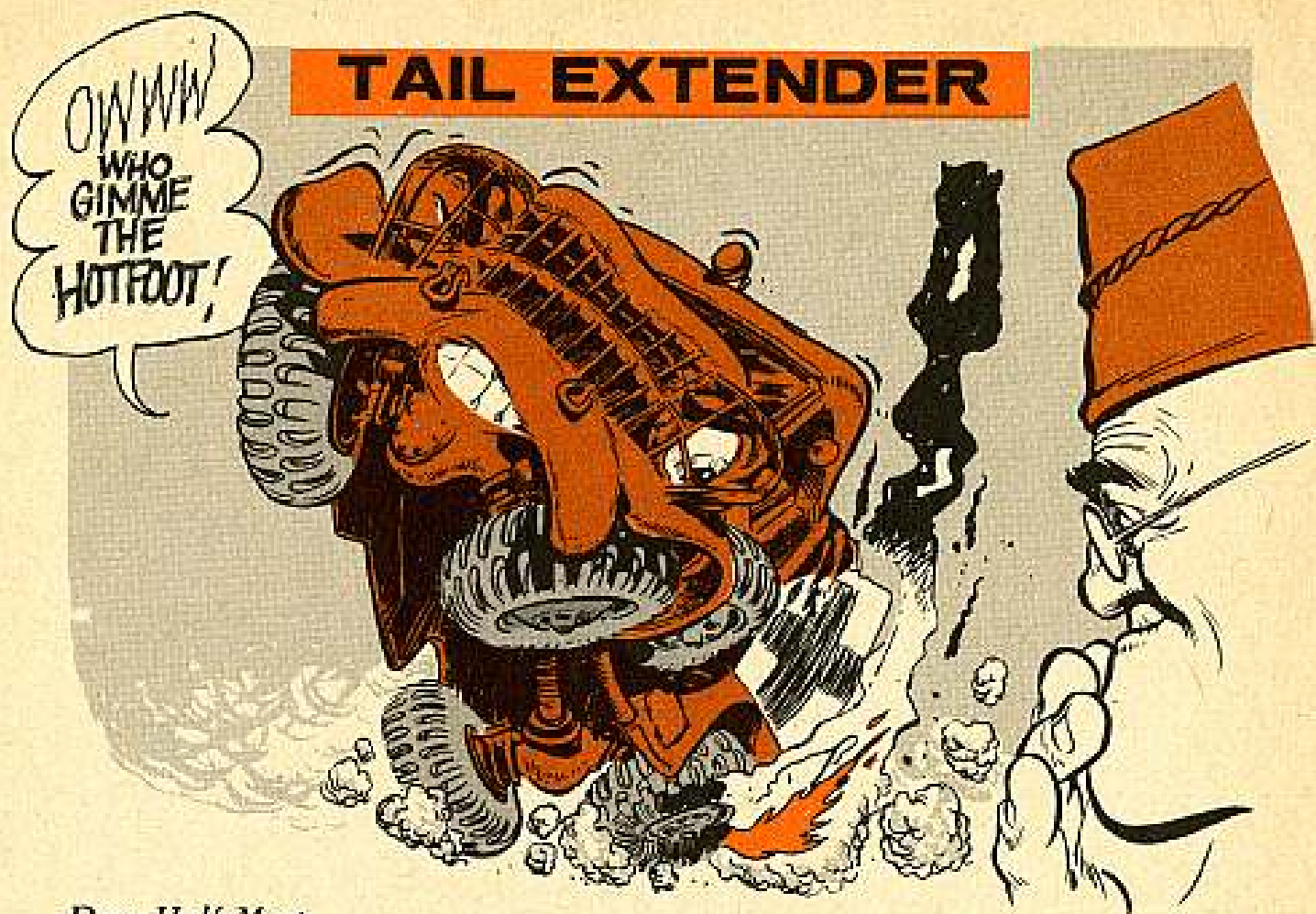

*Dear Half-Mast,*

*During our summer encampment, heat from the exhaust pipe on one of our M43 ¾-ton ambulances destroyed one of its rear tires.*

*This bobtail pipe's said to be made that way for deep water fording, but it's at least four inches too short for safety in normal use. Is there a pipe for this vehicle that'll reach all the way to the rear?*

*Sgt E. W. H.*

Dear Sgt E. W. H.,

Unless you got an M37 tail pipe on that M43 by mistake, Sarge, it's hard to see how you got the kind of tire-burn you describe. Even the M37 pipe discharges exhaust about eight inches from the rear tire and at right angles to it. So even a mixup like that shouldn't burn the tire.

But assuming you've got the right tail pipe—either FSN 2990-735-0371 or FSN 2990-798-0221—that bobtail pipe should have been extended long ago.

MWO Ord G741-W5 (2 Apr 54) authorized the extension on the M43 and the M201 telephone installation truck. But that MWO has been canceled. Besides, the newer model M43's are getting a longer pipe.

There's still danger in that short pipe, though—to you and your passengers. It may let carbon monoxide get inside the vehicle. So the pipe should be extended by a field fix just like the canceled MWO—after approval by your local area CO, o'course.



Natch, you'll replace this extension with your fording gear when you go fording.

*Half-Mast*

## KIT-OR BIT BY BIT?

Dear Half-Mast,

Some of our M38A1 Jeeps have side curtains that need a repair job. Others never had any curtains, so we need both the curtains and hardware to put 'em on. PS 60 gives the numbers for each curtain, but our Ordnance support just has the canvas kit, FSN 2540-039-7803.

How do we go about getting just the parts we need?

SP5 C. J. B.

Dear SP5 C. J. B.,

What you'll need for a Jeep weatherproofing job depends on whether attaching parts are now on the vehicles.

Assuming that each of your Jeeps now has a Cover, top with rear curtain assembly, FSN 2510-040-2558, you'll find all the items you need to complete the job in Kit, canvas closure, FSN 2540-039-7803 (G249). This kit has all the canvas and hardware attaching-items needed for one M38A1 Jeep—plus instructions on putting them on.

The FSN's listed in PS 60 for individual canvas items are the numbers you'd use if you want to order just replacement canvas. That is, if you don't need the hardware items to attach 'em.



*Half-Mast*

# COMMUNICATIONS

YOU, TOO,  
CAN BE A...

## MASTER PAINTER



A touch of the brush makes the difference.

And even if you're not a Rembrandt, you can still paint a good PM picture on your radio or telephone equipment.

Just use the touch-up technique. Not too much paint and not too little. Many a piece of Signal gear has staggered back to the rear so covered with layer over layer of paint that the support crew had to dig deep to find the dials, decals, plates, etc.

So when rust shows, or a few cracks open up in the paint on your panels, covers, cabinets, etc., give the gear the quick brush-off treatment.

First, get rid of the dirt and grease and stuff like that. Best thing to use is some Cleaning Compound, Liquid. A pint can is plenty—FSN 7930-395-9542 (Sig). After that use some fine grade sandpaper to feather the ragged painted edges. Sand away until nice, clean metal is showing. And then dip in your brush and start touching up. TM 9-2851 can give you more advice than Rembrandt on how to paint that gear—in case you're rusty.

The paint you want to use every time is:

Enamel, Synthetic Lusterless; OD; MIL-E-11237; 1 pt can FSN 8010-598-5951.

It's listed in SM 11-1-8000. Needs eight hours to dry, and one coat's plenty.

That there enamel will even satisfy the official Repair Standard that says "when the original finish cannot be determined, a lusterless green (olive drab) finish will be applied."

There's one finish, incidentally, that you can pretty much leave alone. That's any aluminum (antennas, antenna mounts, etc.) that's been anodized. Because

anodizing is a fancy process that puts a hard, bluish-gray coating on aluminum that'll resist just about anything.

It makes the aluminum feel smooth and polished. Untreated aluminum is a little whiter looking and a little coarse and gritty and not as smooth. So painting any aluminum gadget that's been anodized would be like gilding the lily.

## FALSE IMPRESSION

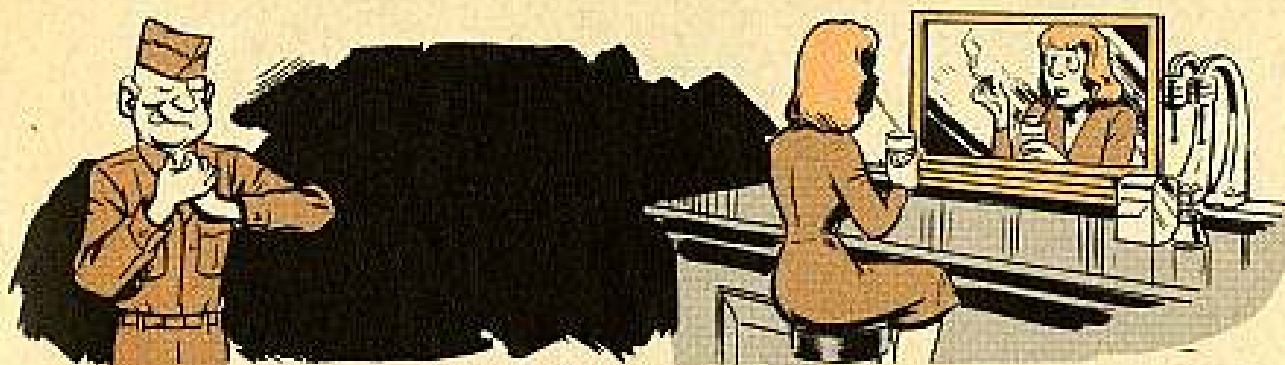

Appearances can be mighty deceiving sometimes.

Take the power output meters on the RT-66/GRC's for example. They can easily give a false impression of what's being put out—and what's not.

False impression No. 1: An operator is sending a message down the line of Set 1 of his AN/GRC-3 when the meter goes dead on his transmitter. Naturally, he figures she's not puttin' out.

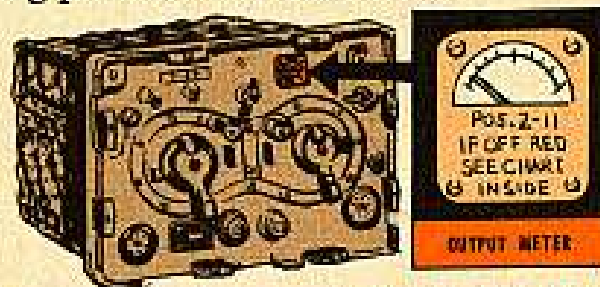

Not necessarily so, because the tiny diode that hooks the meter into the circuit sometimes burns out. When that happens, the meter goes dead—but the set is still putting out a signal strong as ever.

You'll find out soon enough if your RT is dead, but don't give up and get off the net the minute your meter plays dead.

False impression No. 2: A reverse situation, where the meter does show a reading when your set is not transmitting. Tricky but true.



It happens when dirt or MFP (moisture fungus-proofing) fouls up the contact on the antenna switching relay. That sets up a road block in the circuit and chokes off the output 100 per cent.

But, your meter will still give a reading because of the high concentration of electrical current so close to it.

In both cases, when you're sure your meter is giving a wrong reading, shut down and have a repairman check it through.



## A BAD RUB



Keep that radio and telephone gear clean.

By all possible means—and a few impossible ones, too.

Except one. Steel wool! Just picture it—a man rubbing away with a chunk of steel wool. Oh, how the rust and dirt disappear. And, oh how the little steel pieces flake off from the steel wool and sneak down into the chassis.

And then how the blue sparks fly when the set is turned on. Those tiny steel flakes pave the way for a short cut to a short circuit.

No steel wool, please. Better to use a clean rag and some Cleaning Compound, Liquid. A pint can should clean things up—FSN 7930-395-9542 (Sig).

## THAT CERTAIN FEELING

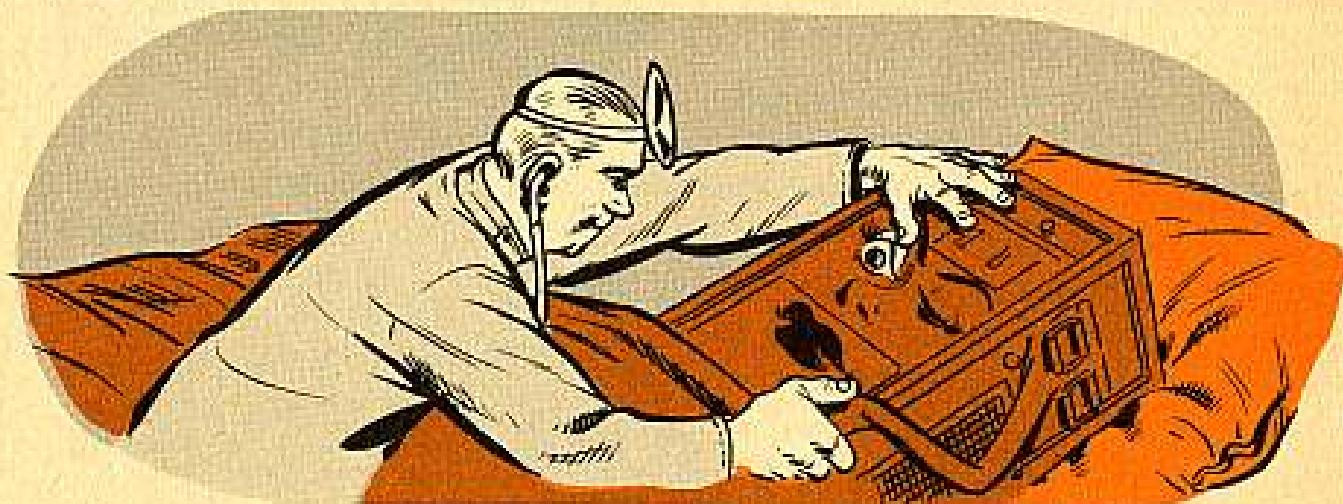

Sometimes a good quick feel is the best way to track down trouble. Using a flashlight, of course, helps to light up the subject.

Any time there's trouble in your radio assemblies, it's always a good idea to hold up on the test equipment and electrical checks until you've run a good, old-fashioned physical examination right there on the spot.

Many times it's quicker, easier and more satisfying to actually lay hands

(gently!) on those tubes, transformers, harnesses, bulbs, etc., to find the source of trouble.

And finding the trouble that way—especially if it's only something like a bad tube or harnesses rubbing together—means your set can stay on the line instead of going to the rear for a fancy checkout. The flashlight will help spot danger spots in the hard-to-see corners of your set.

Some cautions to bear in mind, though: Never feel around just for the feel of it. Poking around on a set that's operating 100 per cent can only lead to trouble.

And long before you do anything, kill the power. If it gets its juice from a power line, pull the power plug. Or just turn off the switch if it's a battery-operated set.

## ALL WRAPPED UP

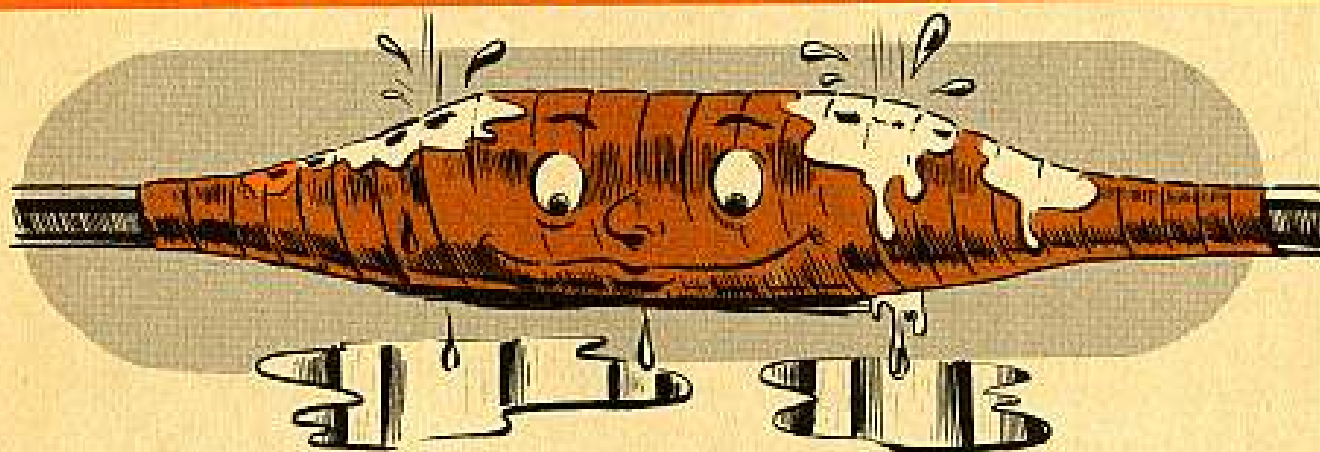

Keep the water out and the current in.

That's the simple idea behind wrapping some vinyl tape around the connectors of your Signal coaxial cables.

Changes in temperature and constant exposure to old man weather begin to break down even the tight grip these connectors make.

To keep water and moisture out, then, wrap those connectors in a bundle of vinyl tape with an adhesive backing. The vinyl, of course, is just about as waterproof a material as you can lay hands on.

Cover the whole connector—as well as about four inches of the cable on both sides. Spiral the tape back and forth about four times, allowing a 50 percent overlap on each winding, just like it says in TB Sig 276 (17 Jan 55).

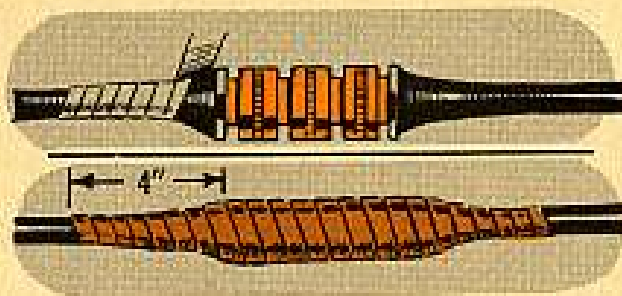

The stuff to ask for is: Adhesive Tape, black,  $\frac{3}{4}$  in wide, 108 ft long, FSN 5970-284-8410 (Sig) in SM 11-1-5970.

## GROUND ACTION

When the volts, amperes, decibels, ohms and all t'other members of the electricity family start jumping around inside your radio sets, there's somethin' soothin' about knowin' they're under control and working for you—and not agin' you.

And that means being grounded right.

Which also means that whenever you're hooking coaxial cable to an AB/15 mast base, the right ground action calls for the right adapter. In this case, Adapter UG-273/U.

This adapter can handle the ground strap from the mast base without interrupting the circuitry. Just clamp the strap to that adapter and you're grounded just right.

But not so with the TM-145 type adapter. They're not made for the AB/15's. If you clamp a mast ground strap on them you'll actually cut the antenna right out of the circuit—giving you more ground than you bargained for.

Check to see that it's the UG-273/U adapter.

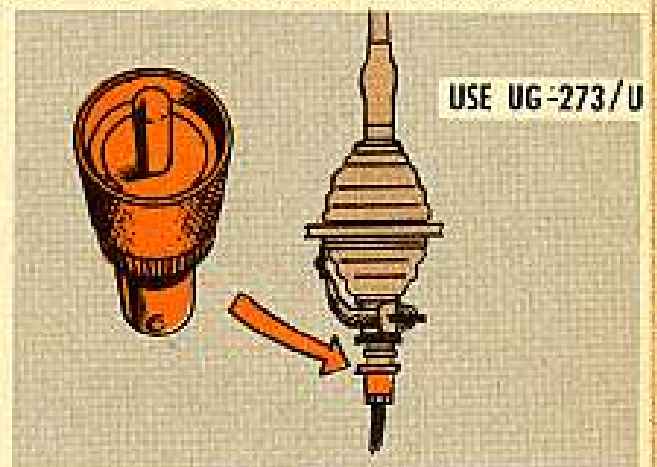

USE GROUND  
CLAMP ON  
UG-273/U

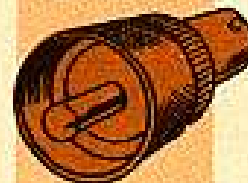

DO NOT USE  
TM-145

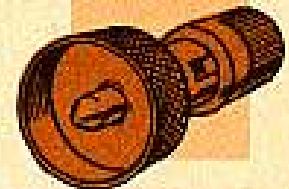

## FORGET IT...REGRET IT

Miss that "small talk" over the phone nowadays? You're apt to miss "big talk" if you forget to keep tabs on the batteries in your telephone equipment.

Eyeball 'em every month or so to make sure the contacts are clean and free from corrosion. Change 'em according to the amount of use you give your jabber set.

Notice weak voice? Change the batteries. And remember—if you're not going to use the equipment for quite a while, take the batteries out or corrosion may step in.



# RADAR

ROUND AND ROUND  
WITH YOUR ...

## TIPSY ONE DOG

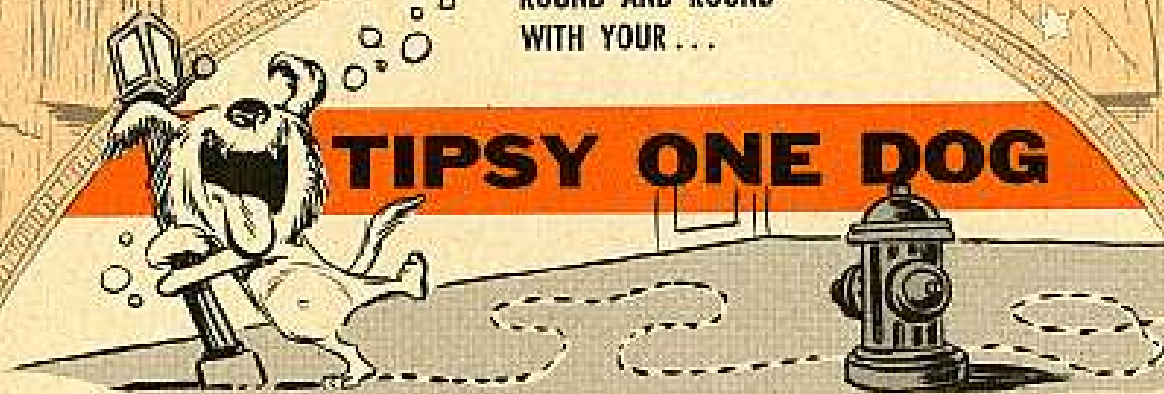

Been some grinding and gnashing noises coming from those Topsy One Dog (AN/TPS-1D) radars. The more they go around in circles the worse the noise gets.

Seems those scanners are developing gear train troubles in their antenna base. Too many gears are getting rusty, chipped and burned out from lack of lubrication.

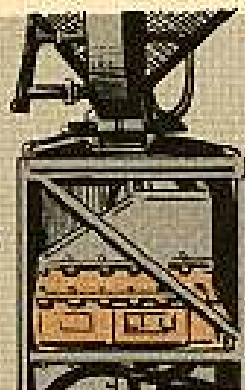

Hard to believe, but the lubricating oil (GO 90) in the base (AB-221/TPS-1D) gets gummy and dirty and soon clogs the gears—leaving you with a sick Topsy Dog.

Keep it healthy by checking the lube level extra close—which is easy enough since MWO SIG 11-1167-4 (It's now MWO 11-5840-218-35/1 (19 Sep 58).) gives you a window on the side of the base for a visual check. And if the weather is cold, be sure the heating unit is working right.

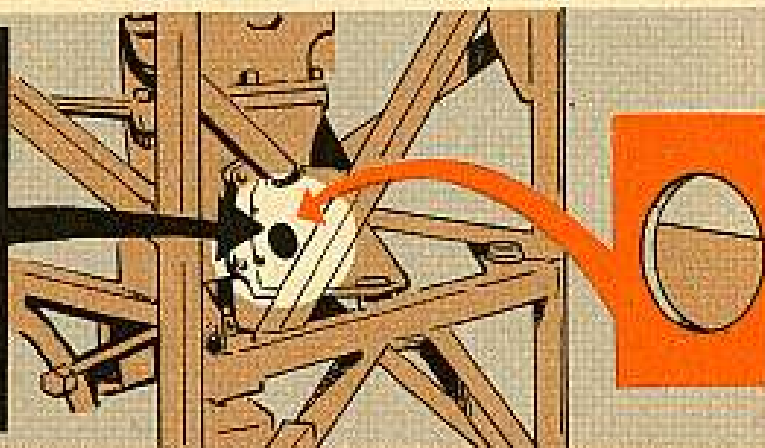

# LOOSE DZUS



When a Dzus is loose, lookout!

Those wing-like fasteners hold the panels of your radio and radar gear in place—and hold them tight. But they can't hold on if they're not tightened up right.

So next time you're ready to slip a front panel back into place, try this easy-on technique:

Line the panel up with the chassis and then make sure the screw of each Dzus fastener is properly "started" into its hole on the chassis. When this is done, turn each Dzus until it's ready for that final quarter-turn that clamps things waterproof tight.

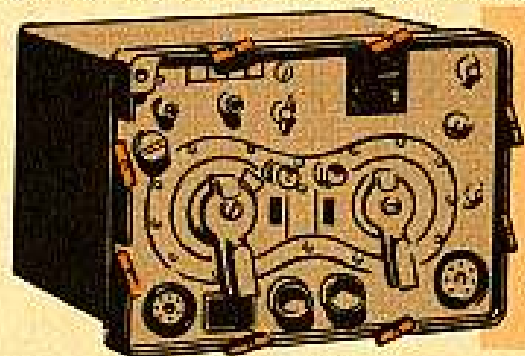

EACH  
DZUS  
IS  
READY  
FOR  
LAST  
QUARTER  
TURN

And then work right around the panel making the final, quarter-turn adjustment.

## WORK AROUND PANEL

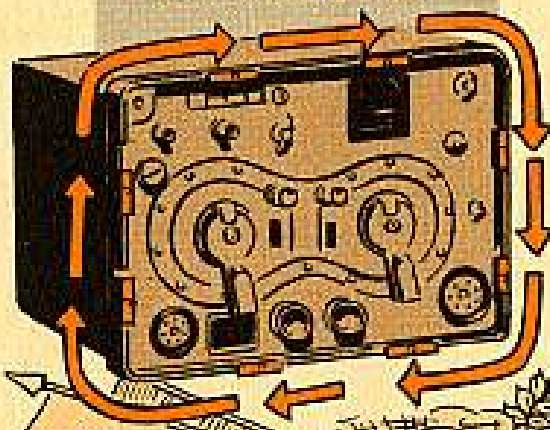

The danger lies in tightening up only one or two fasteners before the others are lined up and ready for final adjustment. That actually takes extra effort on your part and, worse still, puts a mighty heavy strain on the one or two Dzus's that were turned tight before the others.

**NIKE**

**WRONG  
NUMBER**

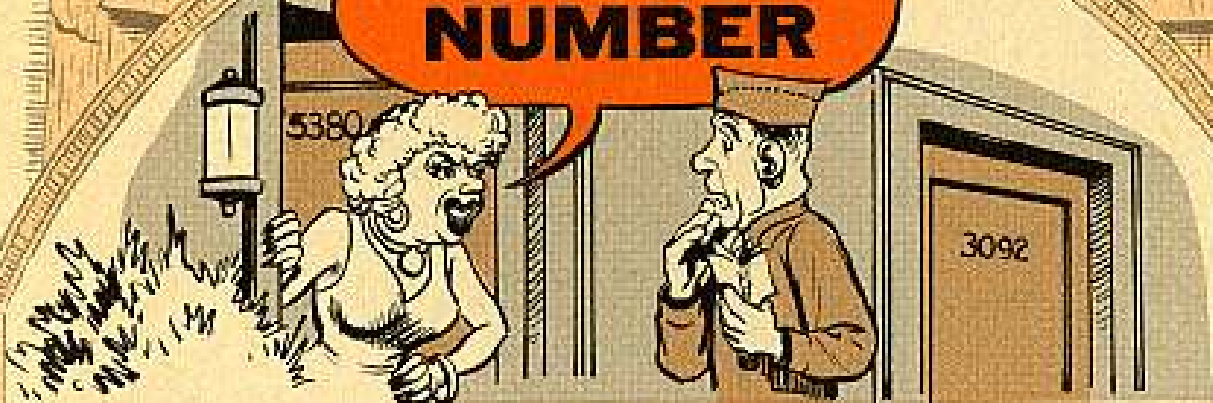

The name's the same but the number's changed.

On the red and black wire leads for the BB-401/U Nike-Ajax and Hercules battery.

Seems that SIG 7 & 8 BB-401/U (9 Dec 57) got its wires crossed and listed those two leads incorrectly.

So if you need one or the other—or both—ask for:

Red Wire w/ Terminal, one end: FSN 6140-620-6011

Black Wire w/ Terminal, one end: FSN 6140-620-6012

## **DON'T OVERFILL**

To save the BB-401/U batteries in your Nike-Ajax and Nike-Hercules missiles from cracked and leaking cells, don't overfill 'em. Keep the electrolyte level showing between the bottom of the inspection window and the red line, not flush with the red line. Natch, it's No-Go if the electrolyte level is higher than the red line or below the bottom of the window.

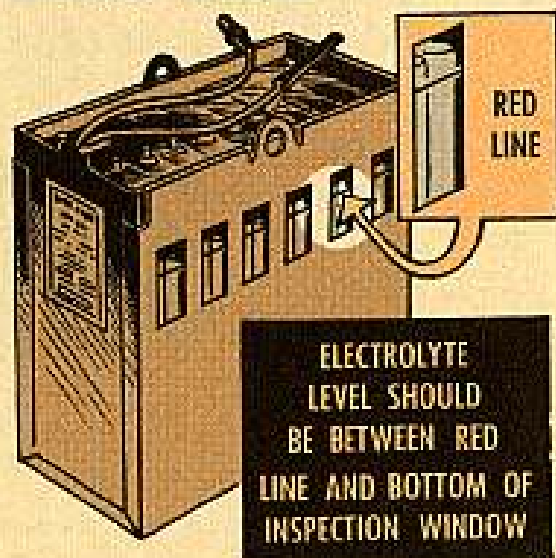

# FUSE NEWS



Dear Half-Mast,

*Is there any method for telling the voltage rating of a fuse by visual inspection? And is there any way to tell a slow-blow from a regular fuse when the glass is clouded up?*

Dear E. D. B.,

E. D. B.

Yes, there is. The information is stamped on the ferrules of most fuses, just like Military Specification MIL-F-15160C requires.

But since there's a code used, it's a little tricky to read it off. A typical fuse might be marked F01GR100A. Or possibly the marking would be broken up into two lines, which might look like this:

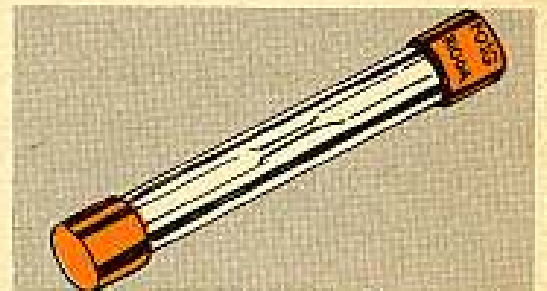

R100A

|                |               |                |
|----------------|---------------|----------------|
| STYLE          | <b>F01 G</b>  | VOLTAGE RATING |
| CURRENT RATING | <b>R100 A</b> | CHARACTERISTIC |

Either way it means the same thing. This particular one translates to a Style F01 fuse, with a G voltage rating (250), an R100 current rating (0.100 amps) and the A characteristic, which means it has normal interrupting capacity (not a slow-blow, and not a special high interrupter).

Now your voltage ratings are always stamped in as a letter, and they translate like this:

| LETTER | VOLTAGE (MAXIMUM) |
|--------|-------------------|
| A      | 32                |
| B      | 52                |
| C      | 90                |
| D      | 125               |
| G      | 250               |
| H      | 500               |
| J      | 1000              |
| L      | 2500              |
| N      | 5000              |
| P      | 10,000            |

The current ratings work like this:

| CURRENT SYMBOL | CAPACITY IN AMPERES |
|----------------|---------------------|
| R001 to R009   | 0.001 to 0.009      |
| R010 to R099   | 0.010 to 0.099      |
| R100 to R999   | 0.100 to 0.999      |
| 1R00 to 9R99   | 1.00 to 9.99        |
| 10R0 to 99R9   | 10.0 to 99.9        |
| 100R to 999R   | 100.0 to 999.0      |

You see how it is—the letter R is your decimal point.



Now as to the style figures, there are far too many of 'em to set down here, but they always lead off the marking with the letter F and two numbers. F01 happens to be a glass tube type, as are 02 and 04, while the 03's are ceramic or plastic. And different numbers have different dimensions.

But that's no problem to you. Just read the numbers off the blown fuse and be sure the one you use to replace it has the same numbers.

*Half-Mast*





MISSILE  
BLASTS



## HANDS OFF...STAY OUT

There's a heap o' maintenance to be done at any Nike site, so why go lookin' for trouble? Like maybe trying to tinker with the internal calibrations of your RF test set, f'rinstance.

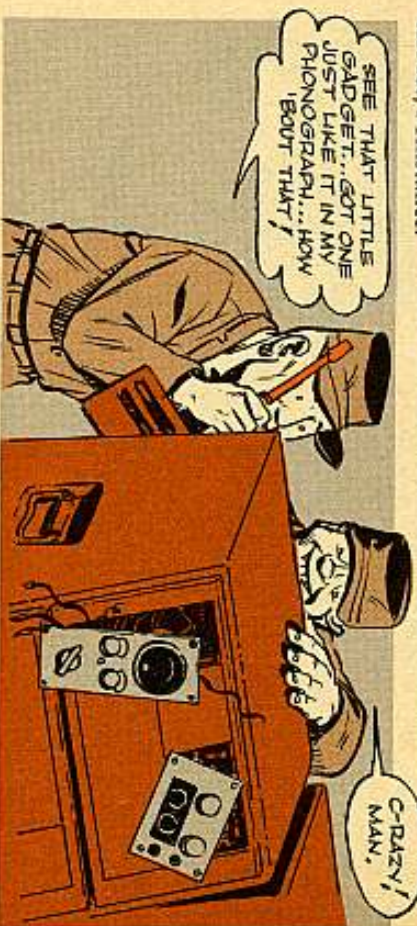

SEE THAT LITTLE  
GADGET...GOT ONE  
JUST LIKE IT IN MY  
PHONOGRAPH...HOW  
'BOUT THAT!

C-DAZY!  
MAN,

Some guys got the notion that a screwdriver is a missile's best friend, and tried to "fix" the trimmer capacitors in the micro-second oscillator or reference oscillator.

Next thing you know, the RF test set had to be sent back to Ordnance for a complete Ord 6 check-out.

So keep local tinkers out of the RF test set—lots of technical know-how is needed to do the job right. If you get tester trouble, send for your organizational mechanic—he'll know just which parts he can replace and what adjustments he can make. If he can't fix it, he'll send it back to Ordnance—they'll look it over and get it in first rate shape fast.

## LEAVE THEM ALONE

You Nike-Ajax men can overdo it when it comes to PM on the commutators in the frequency converters. Heard of one outfit where they cleaned 'em every day and had trouble every other day. Best policy is—eyeball 'em weekly, like it says in TM 5-5035-1 (May 56) but clean 'em just when they need it.

The commutator and slip rings aren't supposed to be brassy bright. Here's the way it works—after a few hours of operation, the commutator turns a chocolate



...AND WE SHINE  
'EM EVERY DAY  
SARGE...REAL  
PM, HUH?

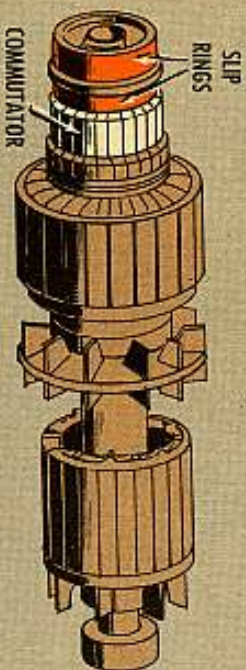

brown with a little polish to it. This shade'll vary in different climates. The big point is that the color'll be the same on all points of the commutator. Later, as the number of operating hours increases, the color'll darken and become uneven. Then, and only then, do you clean the commutator.

It's the same deal on maintaining the collector rings...except that the rings should last a lot longer before they have to be cleaned.

# ASHCANS AWAY

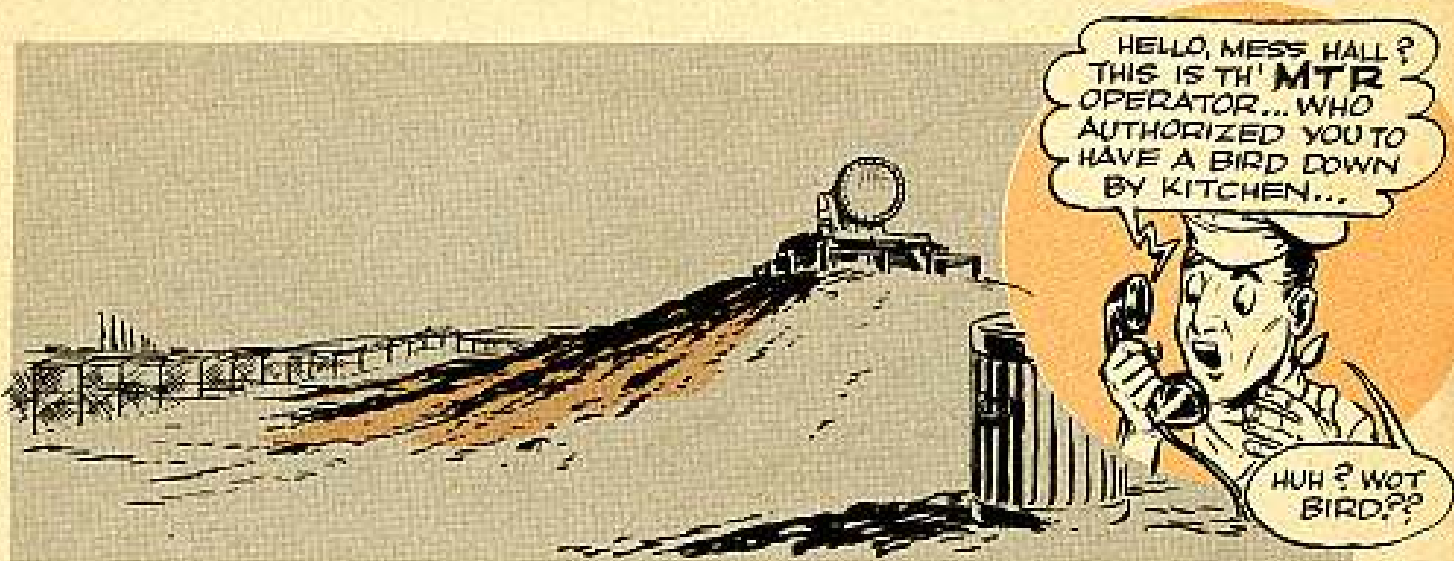

There's nothing like "locking on" a GI can instead of a Nike-Ajax missile when you're checking out your missile tracking radar. Could be downright embarrassing.

You can keep from looking like you were hit in the kisser with a load of beet juice by stashing away some scoop in your noodle. It reads like so:

Get to know the signal that bounces back off the missile so's you can tell it from ground clutter in the area.

Separate the missile beacon and MTR transmitter signals by at least 200 megacycles to pick up a minimum of ground clutter.

Keep stuff out of the launching area that could give a strong enough reflected signal for the MTR to lock on.

Check the coordinates of the missile and make sure you're pointed at 'em... and send a man to the MTR and have him look through the telescope at the launching area to see where the antenna is pointing.

## DISCHARGED FUSE

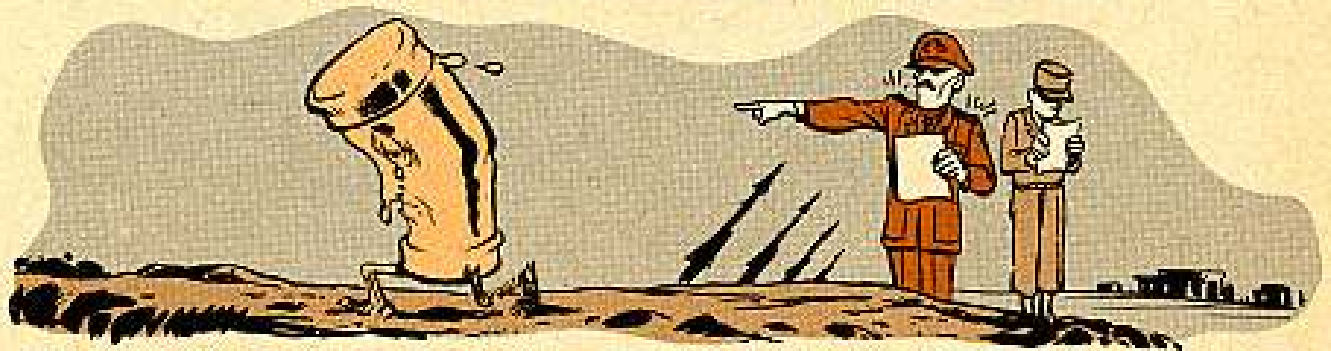

You know that 5-amp, 25-volt cartridge-type fuse that shows up in Ord 7 SNL Y4. According to the supply manual, the FSN 5920-280-3535 fuse is used in Nike-Ajax external guidance equipment.



The latest scoop is that the fuse has been drummed out of the corps... as far as the external guidance equipment goes, that is. The one you want now is a 5-amp, 115-volt fuse. It comes under FSN 5920-322-7574.

Ask your support unit to buck your requisition on to the supply depots 'cause this fuse is there just waiting to be issued to Ord 7 SNL Y4 users.

## GOTTA LEAK?

Could be—especially if you've got a Model BAF-55118 Recony air conditioner (FSN 4120-595-0742) with a serial number from 2001 through 2338. Hear tell that some of 'em using the duct adapter kit for dual installation have been losing some of their 18,000 BTU's.

The air's been getting out where the discharge and the return plenums fasten to the air conditioner cabinets. A heavier gasket's the answer and the later models have been equipped with 'em.

To keep your dual installation of the BAF-55118 equipment air tight, you'll need 31 feet of  $\frac{3}{8}$ -in x  $1\frac{1}{4}$ -in rubber gasket. Fourteen feet, 1 inch will go for the discharge plenum and 16 feet,  $8\frac{1}{2}$  inches for the return plenum. Order the rubber from your direct support unit (Jarron Products Co., part number C510-310, or equal will do the trick). It's a local purchase item.

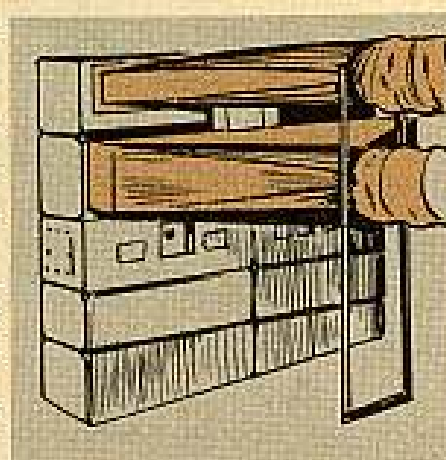

TO MAKE THE REPLACEMENT, TAKE OFF BOTH AIR PLENUMS... STRIP OFF THE  $\frac{1}{8}$ -IN RUBBER GASKET THAT CAME WITH THE CONDITIONER AND REPLACE WITH  $\frac{3}{8}$ -IN GASKET. CUT SNUG FIT.

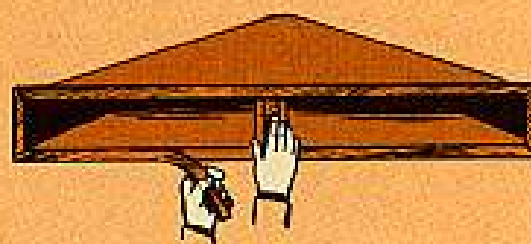
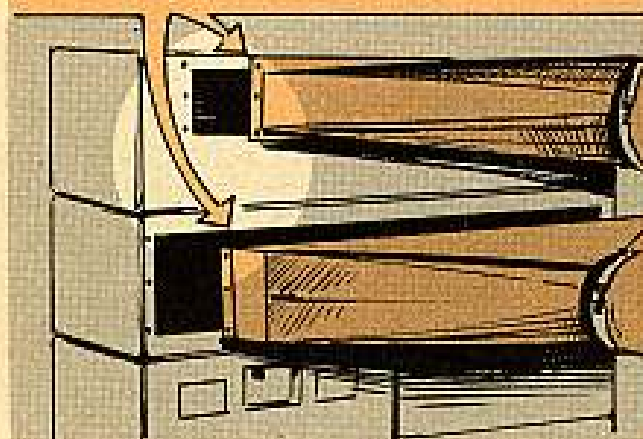

Cut the gaskets at the corners for a snug fit. Then you give it a coat of rubber cement to make sure you have a good seal before you put the plenums back in place.



## MIRROR MAGIC

You don't have to be a contortionist to take a squint at the O-rings in your Nike-Ajax missile—the ones located under Tunnel No. 3.

There's a tool in the system to make the job a lot easier. It goes under the name, Mirror, mouth, examining: magnifying glass, cone socket, without handle, FSN

FSN 6520-541-9350



FSN 6520-541-9005



EXAMINING O-RINGS WITH MIRROR

6520-541-9005. (Medical. That's right—it's a dentist's tool.) The handle that goes with it comes under FSN 6520-541-9350...and is called Handle, mouth examining mirror.

Both the mirror and handle are organizational tools, found in both Tool Set, Common, Mechanical Assembler, Guided Missile...and Tool Set, Common, Electrical Assembler, Guided Missile.

If your set doesn't have them, requisition the mirror and handle separately. They don't come as a single unit.

## NO LOAFERS WANTED

Keep your Nike-Ajax missile working right by removing every trace of acid around the oxidizer filter fittings, like it says in TM 9-5001-19.

The best way to do the job is to keep a neutralizing solution (5 pounds of bicarbonate of soda dissolved in 10 gallons of water) handy when fueling or defueling. When you're through, put the plug back in the fitting and sponge all around the fitting with the bicarb solution. Then, wash down the same area careful-like with plenty of water, so's you remove all traces of the residue.

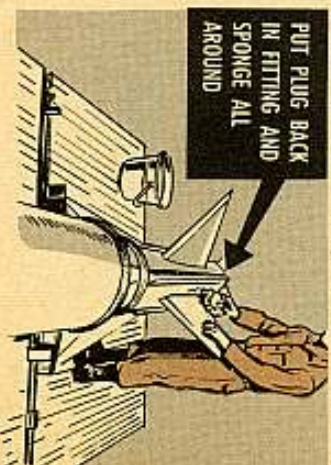

PUT PLUG BACK IN FITTING AND SPONGE ALL AROUND



COULD YOU PLEASE HURRY SIR? I NEED THAT MIRROR TO CHECK THE O-RINGS.

## GIVE HOOTS FOR BOOTS

Did you Nike-Ajax and Herc guys know there's a new type rubber switch boot for toggle switches awaitin' for you in the supply system?

That's right...the boot—like the one on your test power control unit—has been replaced by one that looks like so.

The number you need for requisitioning the new one from Ordnance is FSN 5975-535-9720.

And, if you're looking for scoop on getting a boot for the new type push-button switch, what you want to tell Ordnance is that the Ord Part number is 8909704. You need that scoop because the boot hasn't been given a Federal Stock Number.

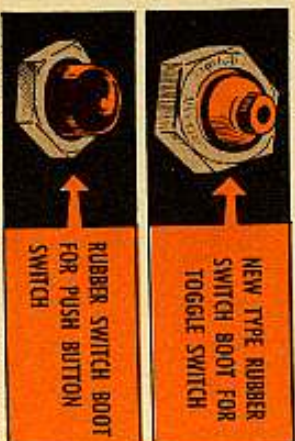

NEW TYPE RUBBER SWITCH BOOT FOR TOGGLE SWITCH

RUBBER SWITCH BOOT FOR PUSH BUTTON SWITCH

## LOG IT

Sure...it takes time, but it's important to keep your battery commander's Log Book up to date whenever you apply MWO's or make repairs to equipment at your Nike site.

One headache is recording work done by your support unit. When one of those guys comes to your unit to do some work, keep telling yourself you're not gonna let him slip out the gate until he puts the scoop in the log book. The same goes with any poop that is recorded in other places—like the missile log book. Get it down in black and white.



DON'T GET FLUSTERED, BOY! ALL WE WANT 'T'D DO IS TO ENTER THE SCOOP IN THE LOG BOOK...BEFORE YOU GET OUT OF THE GATE.

And don't forget to put the scoop in the books yourself—when you make the repairs or modifications.

RIG YOUR CAT  
WITH THESE NEW...

# TRACK SHOE NUTS AND BOLTS



Got some new track shoe nuts and bolts for your Caterpillar tractors...D6's, D7's, and D8's.

You'll find that even though these nuts and bolts are shorter than the ones you're using now, they'll take lots more punishment. 'Course, the big deal here is you don't need to use any lockwashers with 'em, but you do have to torque 'em high.

What's more, you can also use the new bolts with the former nuts...or the new nuts with the old bolts. In either case, you don't use any lockwashers.

You get these improved nuts and bolts through local procurement.

Here's a rundown on the nuts and bolts:

| TRACTOR MODEL              | FSN           | MFG. PART NO. | LENGTH                             | TORQUE   |
|----------------------------|---------------|---------------|------------------------------------|--|
| <b>NEW TRACK SHOE BOLT</b> |               |               |                                    |  |
| D6                         |               | 140-7H3596    | 1 <sup>15</sup> / <sub>16</sub> in | 450 foot-pounds (± 50) when used with new nuts         |
| D7                         | 5306-567-3404 | 140-7H3597    | 2 in                               |  |
| D8                         |               | 140-7H3598    | 2 <sup>3</sup> / <sub>8</sub> in   | 325 foot-pounds (± 25) when used with old nuts         |
| <b>NEW TRACK SHOE NUT</b>  |               |               |                                    |  |
| D6                         | 5310-550-2992 | 140-7H3606    | 5/8 in                             | 450 foot-pounds (± 50) when used with old or new bolts |
| D7                         |               | 140-7H3607    | 23/32 in                           |  |
| D8                         |               | 140-7H3608    | 13/16 in                           |  |

| TRACTOR MODEL              | FSN           | MFG. PART NO. | LENGTH              | TORQUE   |
|----------------------------|---------------|---------------|---------------------|--|
| <b>OLD TRACK SHOE BOLT</b> |               |               |                     |  |
| D6                         | 5306-263-8924 | 140-2F1009    | 2 $\frac{1}{16}$ in | 450 foot-pounds ( $\pm$ 50) when used with new nuts  |
| D7                         | 5306-260-4502 | 140-S1577     | 2 $\frac{1}{4}$ in  |  |
| D8                         | 5306-508-2552 | 140-7F8619    | 2 $\frac{3}{8}$ in  |  |
| <b>OLD TRACK SHOE NUT</b>  |               |               |                     |  |
| D6                         | 5310-423-8945 | 140-2B9512    | 49/64 in            | 325 foot-pounds ( $\pm$ 50) when used with new bolts |
| D7                         | 5310-271-4656 | 140-1B4433    | 27/32 in            |  |
| D8                         | 5310-274-7734 | 140-1B4434    | 1 in                |  |



If you've got one of those Engineer rotary compressors, remember to use nothin'but non-detergent oil in it.

You indentify the right oil by this number: MIL-L-15016A.

Here's what you want:

| <b>LUBRICATING OIL, GENERAL PURPOSE</b> |                   |             |
|---|-------------------|-------------|
| 32° to -10° F (20 weight)               | FSN 9150-223-4137 | 5-gal drum  |
|   | FSN 9150-235-5578 | 55-gal drum |
| 32° to 130° F (30 weight)               | FSN 9150-231-6639 | 5-gal drum  |
|   | FSN 9150-231-6641 | 55-gal drum |

Of course, you use regular OE in the engines that drive the rotary compressors, but you use only non-detergent oil in the compressors. Just like the LO says.

Detergent oil will bust up your rotary compressors.

## ARMY AIRCRAFT



## LET'S NOT SLIP A DISK

Surely not on your spine, although lots of people seem to be doin' it these days. And not on your older Sioux (H-13) whirlybirds either, please.

Some pilots are haunting their mechanics trying to get them to slack off on the control disks.

Sure, Sir, we know it makes for easier flying, most of the time. But comes a developing vibration condition, or any other situation that gives you either vibration or excessive control pressures, you'll find that control disk is your good friend after all.

So please to not annoy your worthy crew chief with requests for unauthorized adjustments. When that bird came back from Field Maintenance, the lateral disk was set for a 3-to-4.4-lb drag, the fore and aft was set between 4.2 and 6.1 lbs... like para 7-83, page 7-38 of TM 1-1H-13C-2 (June 58) says.

## DRY RUN DRIES IT

Just a reminder that oil sometimes accumulates on the clutch shoes of your Sioux (H-13's) to the extent that when you first rev your engine the blades don't start to turn.

So relax, don't flip! Just shut down the engine, wait a minute and fire up again. Most times the first start will have wiped off the oil for you, and you'll be OK on the second try.

Of course, if the dry run doesn't fix you up, or if the problem keeps haunting you, then have your support look at the clutch shoes, which may be worn or glazed.



## IS YOUR AIRCRAFT A GAS CHAMBER?

It's such a relatively short time ago that aircraft were open cockpit jobs, with the pilots and passengers sitting out in the weather, that people still think of 'em as airy, to say the least.

But it's not necessarily so. Present-day aircraft have nice tight cockpits, with nary a stray blizzard anywhere in 'em. Which is fine and dandy, except that the same enclosures and seals that keep the wild blue yonder outta your face also keep the atmosphere inside the cockpit in.

Which means that everyone maintaining aircraft has to be extra careful with the engine exhaust systems, cockpit heating equipment and so on. It's just like your nice tight automobile—an exhaust leak can kill you.

In fact, it has killed people! Not too long ago an aircraft crashed for no apparent reason, smeared the pilot and totaled the ship.

The medics scraped up enough of the former pilot to examine, and found there was so much carbon monoxide in him that it was an even bet he was dead before





he hit the ground. And it was sure that if he wasn't dead, he had passed out, which is still how come the aircraft hit the deck.

Wherefore, leave us review the maintenance allocation charts in the new -20P's (old -18's, para 6i) which says that the inspection and replacement of the exhaust ducts, collectors, etc., is an organizational function. That's another good way to help make sure none of your ships go knockin' the rocks off a public mountain.

## 'AISY NOW!

Faith, and would you be twistin' away at the quarter-inch pipe plug on your Shawnee's oil pump until you busted the poor darlin' entirely? Be 'aisy on her, man.

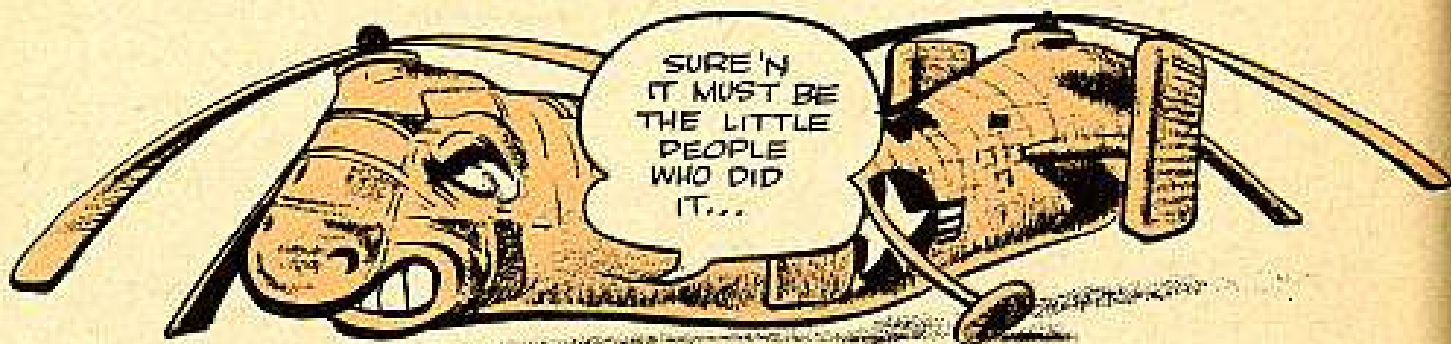

Sure and it's not Murphy's law, exactly, but it's the likes of Murphy that does it, for all of that.

That quarter-inch pipe plug on the oil pump body of your Shawnee (H-21) engines is there to pre-oil the engine, like TM 1-1H-21-2-4 (Oct 57) tells you on page 94, paragraph 5-55. And when you screw it in, all it needs is 60 to 90 inch pounds, which is to say 5 to 7½ foot pounds. And that isn't very much torque.

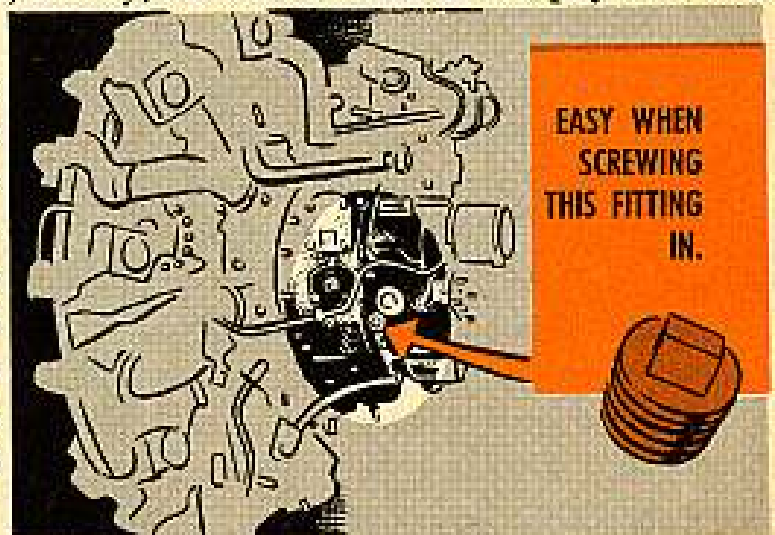

But, that's not only all you need—it's all you can stand. You are screwing a tapered plug into an aluminum alloy housing, and it doesn't take much to bust the housing. It's like driving in a wedge to split a log.

So watch yourself, OK?

And just in passing, there're a couple other pipe plugs in that same area. Pay particular attention to this picture, and be sure it's the right plug that you take out to pre-oil the engine.

## SNAFU?

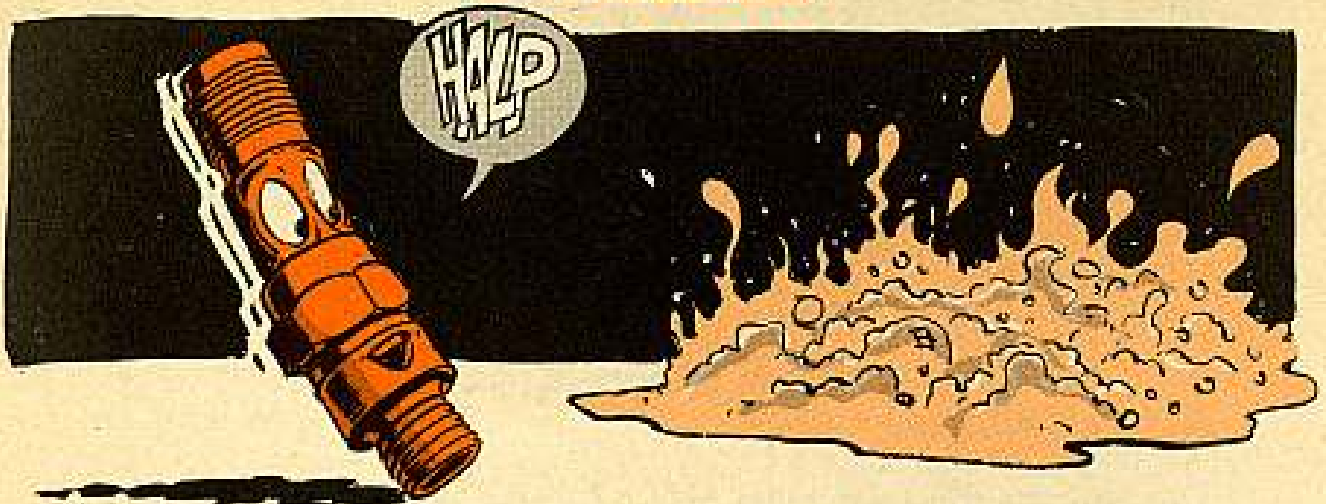

Does the old expression "Situation Normal—All Fouled Up" apply to the spark plugs of your O-335 engines? Or any other aircraft engine, for that matter?

So check, or have your maintenance officer check, with the Quartermaster POL people to see if they are using TCP (tricreysl phosphate, Type II, MIL-T-9188B) additive in the avgas they are issuing you.

This additive, mixed one gallon to each 4000 gallons of avgas, will be a real help in reducing spark plug fouling. But mind you, it only goes into the highly leaded fuels, 91/96, 100/130, and 115/145.

When used with these fuels, it helps prevent lead deposits. But it has no effect on lead deposits once they are formed, so your best results will come from using it right from the start in new or rebuilt engines.

Here's a joker; you've got to have the right mix, because the use of too much TCP can cause valve corrosion and combustion chamber deposits, while using too little will actually give you more spark plug fouling than using none at all.

Remember, TCP is not to be added to the fuel tanks of your aircraft directly. It should be put into the fuel tanker before the tanker is filled, and the whole mix recirculated until it is thoroughly mixed. And you'd best treat this gentleman with proper respect, because he's just as toxic as avgas. Don't get him on your skin and don't inhale the vapors.

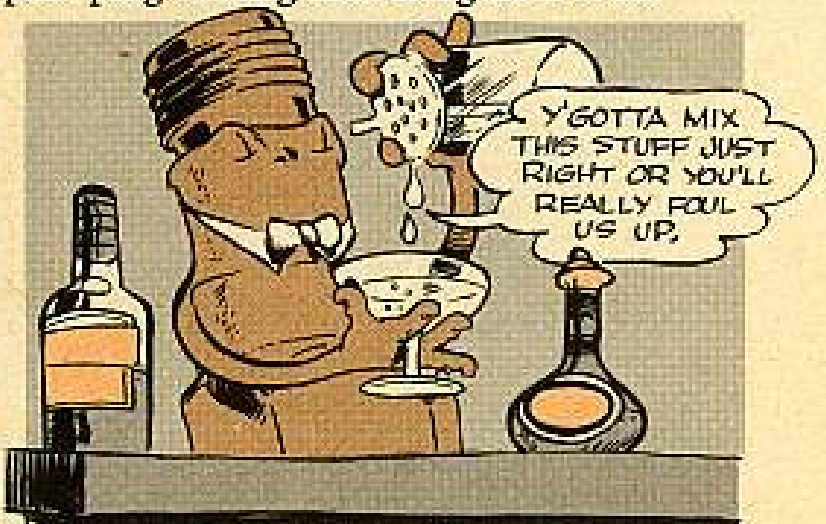

But, properly used, TCP will cut down your unscheduled spark plug changes to the vanishing point, and that's a blessing for sure.

The full official poop can be found in TO 42B1-1-5 and TB AVN 23-2.

# CONTRIBUTIONS



## BIRD BLOCKERS

Dear Editor,

This business of pigeons in the pylons is going beyond a joke. We've been finding 'em in the tail booms of both our H-19's and our H-23's as well as in the big Sikorsky you wrote about before.

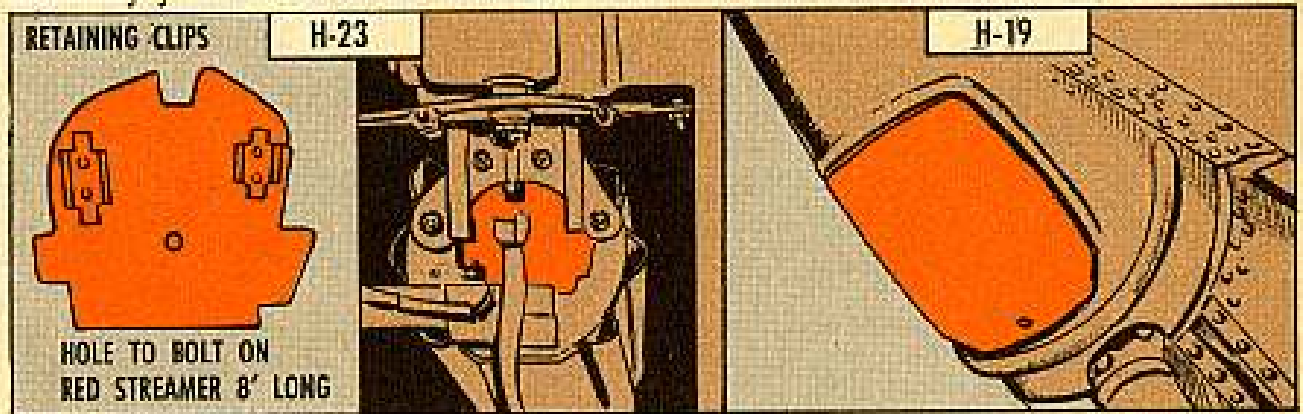

So we've made up a set of covers for the openings in the tails. We put 'em on when we tie down, and remove 'em before flight. The inclosed sketch will show you what I mean.

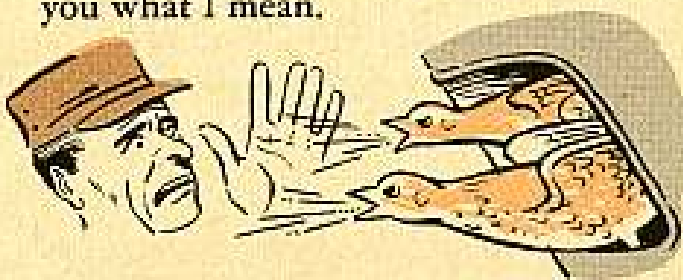

SFC Arthur B. North  
Ft Eustis, Virginia

*(Ed Note—A good notion, Sergeant, and thanks so much for the sketch. It makes it so much easier for us to see what you mean. I notice that you made a small cover for the oil-level check hole on the H-19's as well as the big plate. And see that you have those "remove before starting" red streamers attached to the covers and fastened to the aircraft whenever the plates are in, to remind the crews to take 'em off.)*

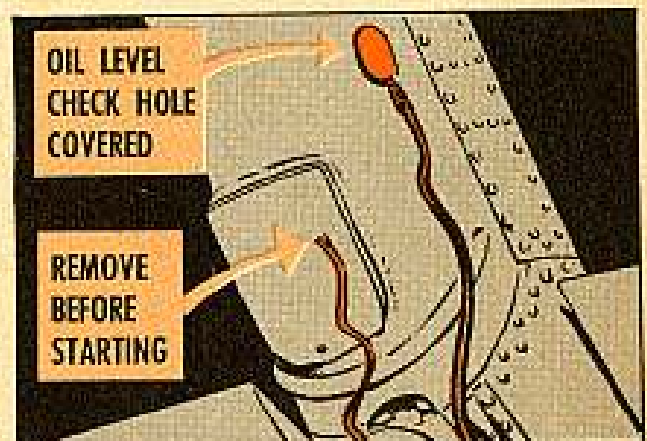

## CLEANING SOLVENT FILTER

Dear Editor,

How to get additional use out of cleaning solvent that'd been gooked up in our organizational shops was a tough problem. We use a heckuva lot of the costly stuff and it hurts to lose any of it.

But, now we've got it licked, thanks to a double-decker filtration unit made after a post-wide survey showed just how serious the problem was.

There're a couple-three ways the filter gadget can be made, depending on materials on hand. What we did was use a 55-gal steel drum for the lower filter and receptacle and the bottom half of a 35-gal drum for the upper filter tray.

Cotton waste was used as the lower filter bed and fine sand in the upper one.

The "refined" solvent was drawn off through a faucet about two inches from the bottom of the big drum. Directly below this faucet is the sediment drain plug. By draining the sediment periodically, we could be sure we had refined solvent.

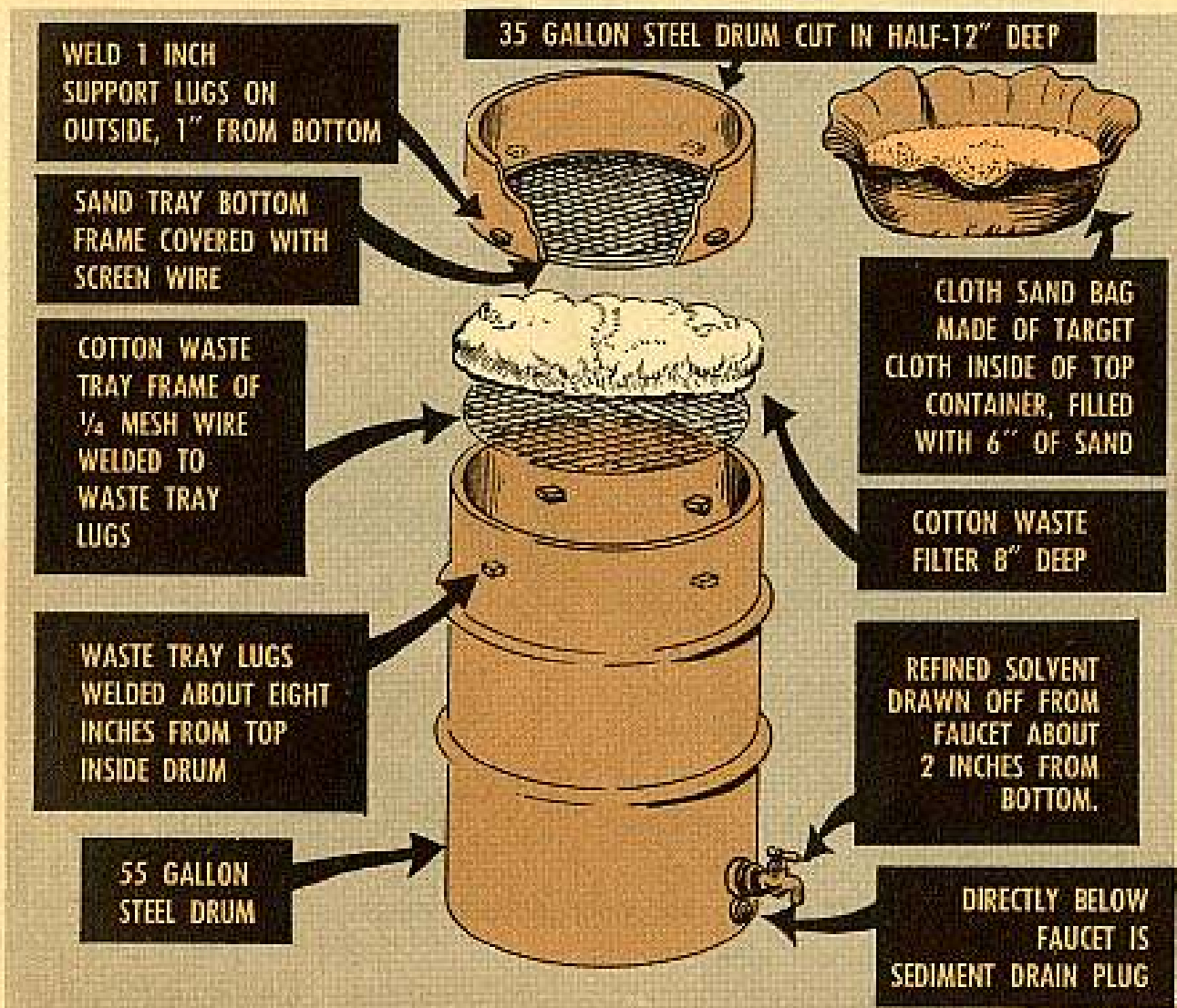

To test the filtration unit we used dirty cleaning solvent that'd been used in the shop on bearings coated with grease, dirt and rust—the gookiest we could

find. Yet it came out clean and clear. In fact, based on the results of this test, we figure to reduce waste of cleaning solvent around here by 75 per cent.

Maybe you'd like to spread the word on this to other outfits using a lot of cleaning solvent.

Arthur H. Smith  
Ft Polk, La.

*(Ed Note—A right smart money-savin' idea.)*

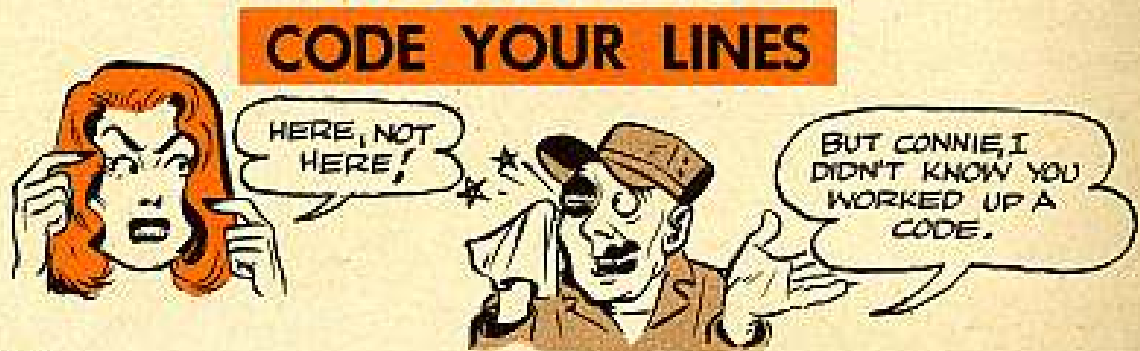

Dear Editor,

On the new AOSI 895-5 fuel injection engines we have found that it is easy to make the wrong connections at the vapor separator. Both the fuel-injector-return-line and the vapor-line have the same fittings, and will fit either outlet from the vapor separator.

Unfortunately, if you cross the lines and connect them to the wrong ports on the vapor separator, you can come up with raw gasoline at the AC fuel-pump pressure flowing freely into your right intake manifold. This leads to the worst hydrostatic lock you ever saw.

I think the fittings should be changed so that it would be impossible to make the wrong connections. But in the meantime, I'm identifying the injector-return-line and fitting with one dot, and putting two dots on the vapor separator line and fitting.

This will at least help prevent the wrong connections.

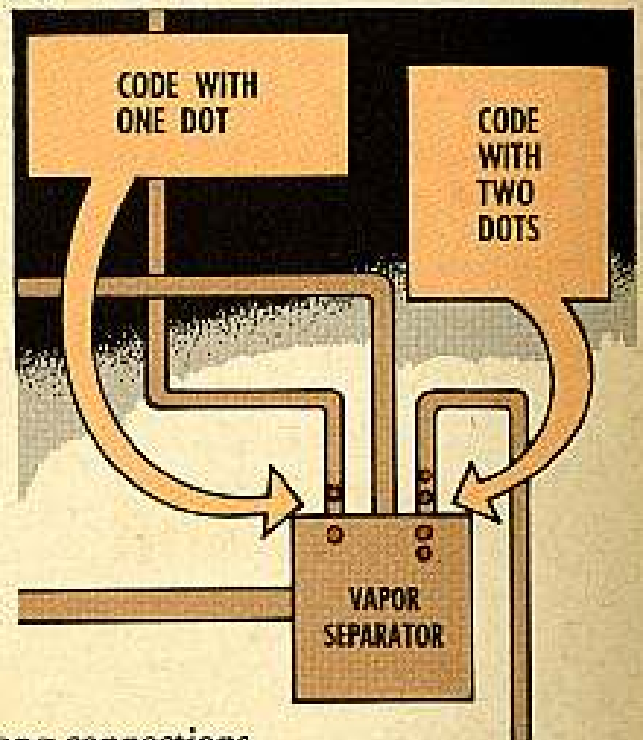

B. A. Morgan  
Ft Bragg, N. C.

*(Ed Note—While the design people are considering changing the fittings, your color code can be saving engines right now as part of an education campaign.)*

# Connie Rodd's

## BRIEFS



### Not for you

Don't get to stewing about not being able to get an M48 or M48E1 machine gun mount for your M38 or M38A1 Jeep. It shows up in some TOE's, but the mount went on the dash of the old World War II ¼-ton utility trucks—the GPW and MB models. Today's Jeeps use different model pedestal mounts.

### Bang-up TM

If you don't already have it, make room on your assembly building pub shelves for TM 9-1970-2. It's loaded with scoop on taking care of Nike-Ajax ammo. And some parts hash over the care of protective clothing.

### Put on pressure

Seem like the boom on your M74 tank recovery vehicle can't take the load it's supposed to? Try **upping** the pressure 100 PSI on the relief valves which control the boom winch motor pressure to **2200 PSI** and the auxiliary winch motor pressure to **1500 PSI**.

### Under Wraps

It's a smart armorer-artificer who keeps small arms repair parts under their original wraps until he uses 'em. That blocks moisture which could open the door to rust. And with parts that don't come packaged, use a light coat of oil to keep rust away.

### Well, skive this!

It'd behoove you shoe repair shop operators to latch onto Change 1 (6 Oct 58) to TM 10-262. It contains a Maintenance Allocation Chart that tells who does what and when—all along the line.

### Pop 'em

Been looking for a tool that'll pop the snubber bearings in your M48-series tanks? Seek no more. It used to be listed as Remover and Replacer, snubber bearing, FSN 5120-098-6724, but now it's called Puller Mechanical, FSN 5120-630-8744, in Tool Kit, Organizational Maintenance (2d Echelon) Special Basic, Set B. Your battalion's got it.

### Telephone rusty?

You say you got troubles 'cause rust is ruinin' the outside telephone equipment on your M41-series light tanks? MWO 9-2350-201-20/2 (25 Sep 58) solves your problem. This **urgent** MWO tells you how to go about installing a new telephone cover kit.

### Picture story

All your pioneer tools in place on those M-series wheeled vehicles? It's a cinch to get 'em right and dodge the gigs if you thumb through the pictures in TB Ord 2300-20/4 (18 Aug 58). It shows stowage locations and brackets with the actual tools in place.

**Would You Stake Your Life on the Condition of Your Equipment?**



## *Now... Like Then—*

An Army-wide directive (like an AR) is designed to serve as a guide for subordinate commands.

Command and unit operating procedures pin down just how such directives apply under local conditions.

That's why, when the word gets to company, battalion and battle group level, it's like this:

Until told otherwise, you follow your own outfit's SOP—(Standing Operating Procedure)—that's the official word as far as you're concerned. (See Page 29)