

Issue 68

PS

1958 Series

THE
PREVENTIVE
MAINTENANCE
MONTHLY

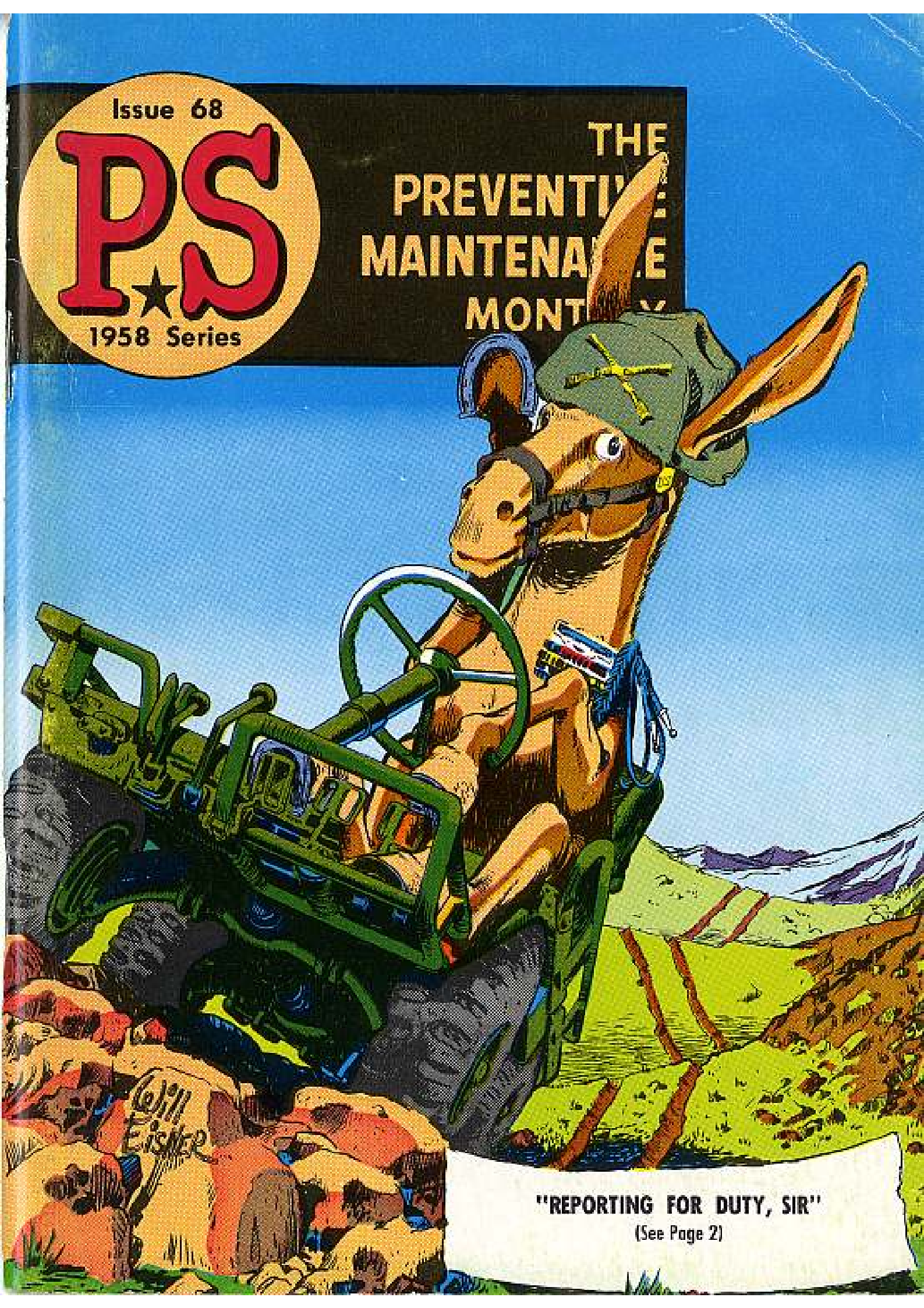

"REPORTING FOR DUTY, SIR"

(See Page 2)

On Tactical Vehicles . . .

IT TAKES TEAMWORK

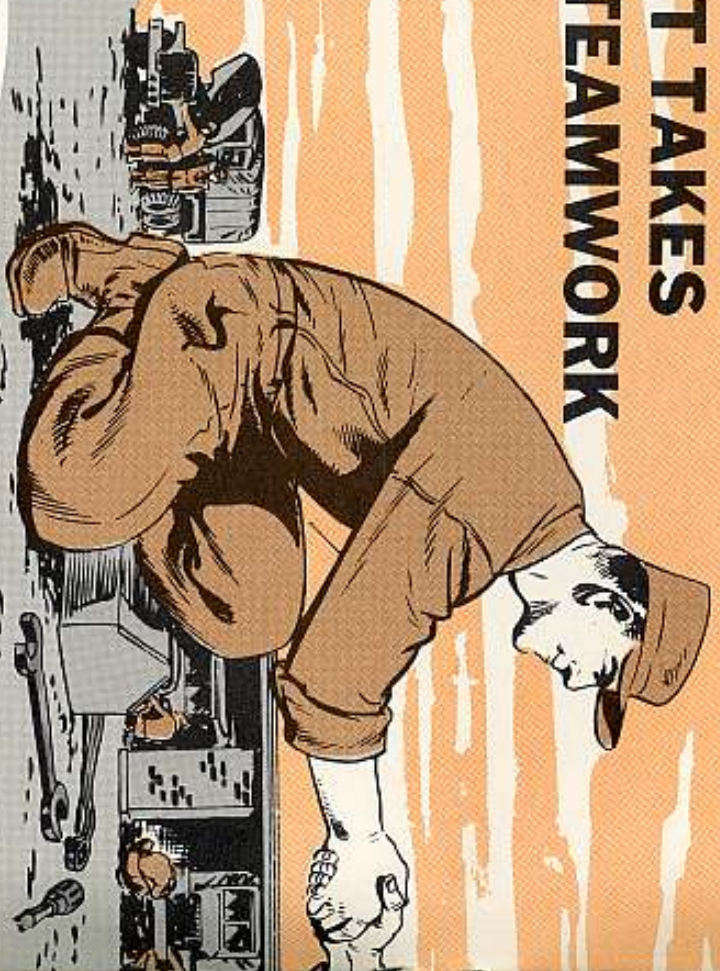

Cooperation and teamwork are two words that every driver and second-echelon mechanic must keep in mind to make everyone's job a lot easier and to keep those vehicles rolling like they should.

To wit—a driver (or operator) is more than just a driver, and a mechanic is more than a mechanic. If they play it smart, both these men go all out for the other one.

For the driver—para 14b of TM 9-2810 (Oct 53) talks about first-echelon participation. It says that the driver should help the mechanic in pulling second-echelon services on his truck. For example, if your mechanic's tied up and

it's time for your truck's tires to be rotated—a second-echelon job—there's no reason why the driver can't do this. The job'll get done a lot faster.

Figure it this way—the driver is an operator of a vehicle, but he's also sort of a junior mechanic. There's no reason why the driver can't do a lot of second-echelon work, if he does this work under the eye of the mechanic. This keeps a busy mechanic on more important jobs.

On the other hand, a mechanic, even a busy one, should be ready to help out a driver in doing first-echelon maintenance, if he's needed. Change 2 to TM 9-2810 says the B maintenance service is done by the crew or operator of a



vehicle—supervised by squad, section and platoon leaders, and assisted by company or battery mechanics.

There can be times (but they're pretty rare) when a driver just can't do his after-operation and weekly services—either he's too busy or his vehicle is on the go 'round-the-clock. In this case, second-echelon can help out on the maintenance services, even though these services are tabbed first-echelon. FM 25-10 (Feb 53) covers this in para 34d.

So, you see, the whole deal boils down to first and second echelon working together—teamwork and cooperation.

PS

THE
PREVENTIVE
MAINTENANCE
MONTHLY

Issue No. 68

1958 Series

Published by the Department of the Army for the information of organizational maintenance and supply personnel. Distribution is made through normal publication channels. Within limits of availability, older issues may be obtained direct from Preventive Maintenance Agency, Raritan Arsenal, Metuchen, New Jersey.

IN THIS ISSUE

EQUIPMENT

Wheeled Vehicles	2, 10, 14, 24, 26-42, 63, 64
Tracked Vehicles	18, 23, 25, 61
Publications and Forms	23, 56-60
Missiles	44-49
Refrigeration Units	50-51
Army Aircraft	52-53
Hand Tools	54-55
Immersion Heaters	62

DEPARTMENTS

Gonnie Rodd	23
Question and Answer	37
Contributions	61
Gonnie Rodd's Briefs	65

PS wants your ideas and contributions, and is glad to answer your questions. Just write to: Sgt Half-Mast, PS, Raritan Arsenal, Metuchen, New Jersey. Names and addresses are kept in confidence.

The printing of this publication has been approved by the Director of the Bureau of the Budget (27 Apr 50). DISTRIBUTION: Army: DCSPEP; ACST; DCSOPS; DCSLDS; ACSHC; CANO; GAA; OUSAASOTC; OAF; OINFO; TIG; TTAG; OLL; OOH; ONGB; OCSMWR; Technical St. Div.; Chaplain Bd.; CAME Bd.; TAG Bd. USA; USA Int'l Bd.; Technical St. Div.; USCOMVARD; OS Maj. Genl.; MPW; Arents; Corps; Div.; Bng; Regt; Bn; Co; Btry; Pl & Comp; Svc Company; Bn Svc Sqn; Joint Sqn; Specialized Sqn; PMSI; Sr Div Units; PMSI Jr Div Units; PMSI Maj Sct Div Units; Gen Depts; Svc Svc; Gen Depts; Depts; and Tr. Army Comd.; AF; USAFIC; Fld Comd.; AFSPW; Part of Emb (OS); Trans Terminal Comd.; Army Terminals; OS SMO Army; Pg; Arsenal; Concludecom; DB; Engr Maint Cer; RWS; Div Engr; Engr Unit; MG; State AG Special Unit; USAR; MIL Dist Special Unit; for explanation of abbreviations used, see AG 330-9L.

Lodeeaze and Gentlemen... Step right up and meet the one, the only—

MECHANICAL MULE

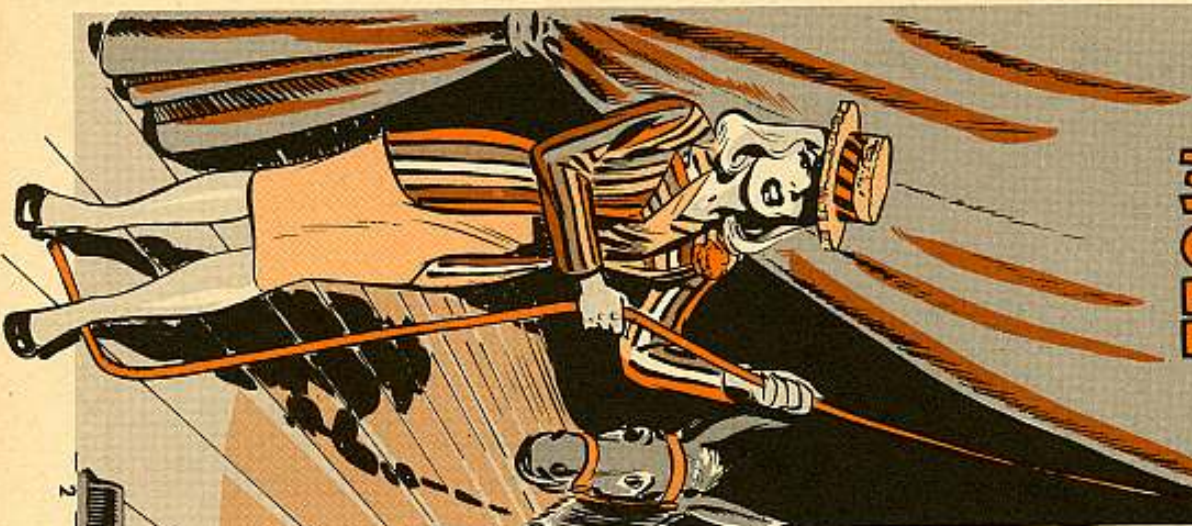

This tin critter is the infantry man's best friend—(next to his rifle, of course). It can carry up ammo, carry back casualties, mount a reckless rifle, haul a mortar, and what's even better, now and then it comes put-putting in with a back-load of hot chow.

It can go just dog-gone near anywhere a rifleman can go. Cross-country, up hill, down dale, and around, in and out between the trees and the rocks. You can steer this little beggar on all four wheels when you have to and it'll weave in and out of a ten-foot circle. In other words, it'll turn on a dime and hand you back a nickel change. It can carry a load that weighs more than it does. She's a dilly.

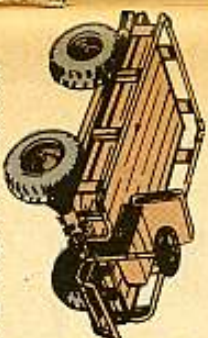

This talk's about the new "Mechanical Mule," the Carrier, light weapons, infantry, 1/2-ton, M274. It's a sort of a four-wheel cart with an air-cooled engine to drive it. There's a driver's seat up front for operation cross-country in rear areas.

When you get up where the trouble is and unfriendly characters are so impolite as to point firearms in your direction, you climb the blazes down off that seat, pull the steering wheel brace loose, swing the steering wheel over front and down and you can back the machine anywhere you want to—while keeping your head down for your health. You can walk behind it or crouch when needed. Half-Mast, being lazy, aims to rig him a sort of toboggan so he can plumb lie flat down and drive.

Your Mule will be around about 4x8 feet, give or take a few inches. With the seat stowed and the wheel over front, she's only 27 inches high. In riding position, your buggy's still less than 4 feet high. Except for the foot and a half or so that the seat takes up in the front corner, the whole platform is available for loading. So, you can keep the load pretty low, too. Payload capacity of the vehicle is 800 pounds—which is more than its big sister, the Jeep, can carry.

There are a couple of disadvantages to this beast. First, she'll only do about 25 miles an hour, and second, you've got no springs. You farm boys know that a wagon without springs is plenty rough.

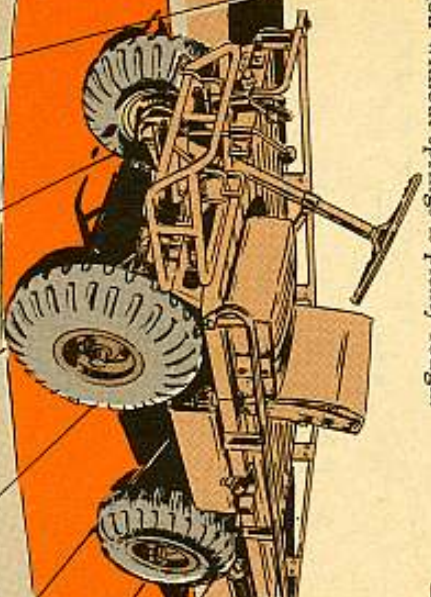

Anyway, this machine isn't designed for the road. Given good roads you'll pick it up, shove it in the back of a deuce and a half truck, block it and then fling the load in behind that. The crew climbs in on top of that and away you all go.

This tin critter only weighs about 900 pounds, so four good men can pick it up up real easy. She's designed to be operated up front where the trucks can't go. There's no cab on her, but then nobody in the front-line area has a cab up anyway, so you get wet when it rains.



OPERATION

So leave us look at this little brute and see how you operate it.

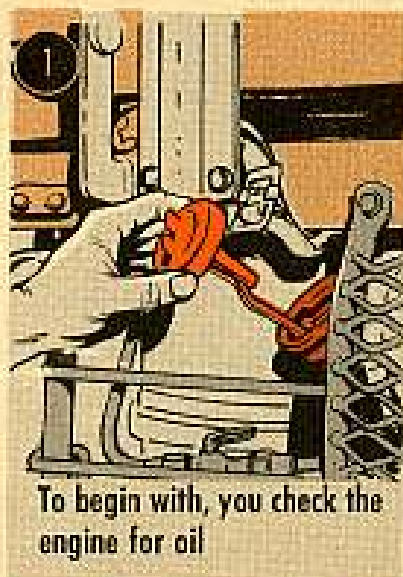
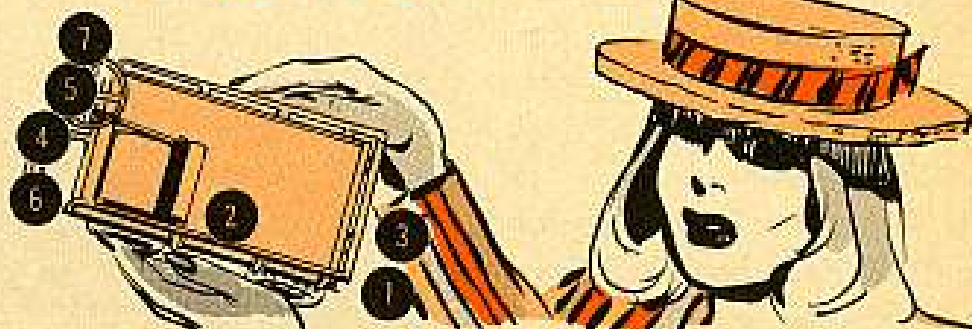

To begin with, you check the engine for oil

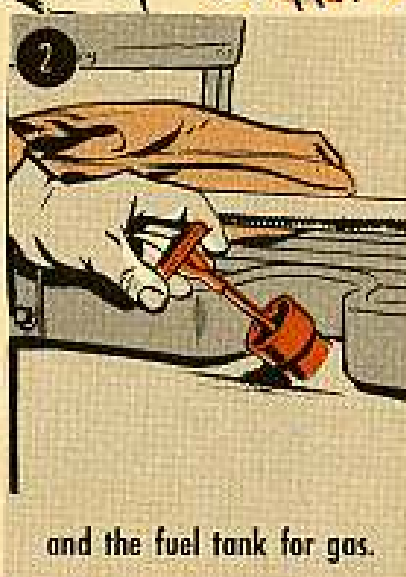

and the fuel tank for gas.

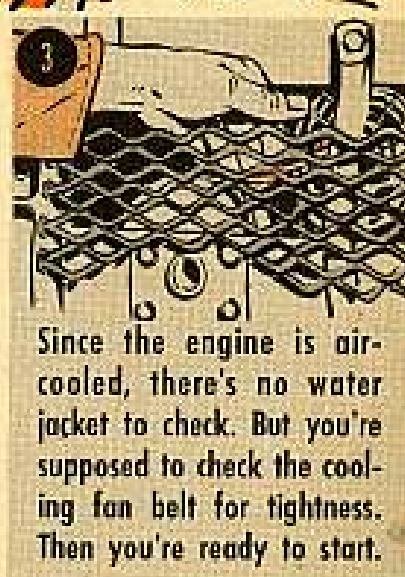

Since the engine is air-cooled, there's no water jacket to check. But you're supposed to check the cooling fan belt for tightness. Then you're ready to start.

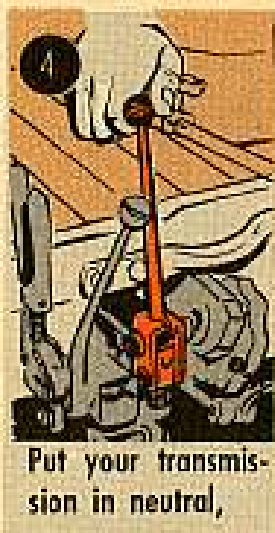

Put your transmission in neutral,

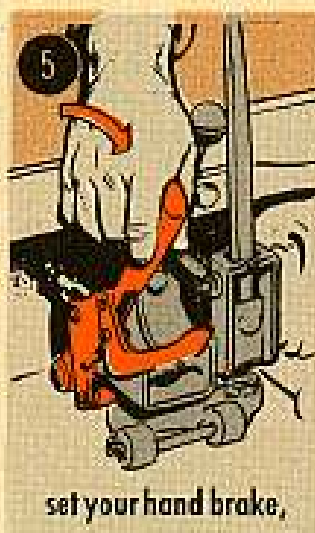

set your hand brake,



turn on your ignition



and pull out the hand choke a little bit if it's cold weather and you think you'll need it.

There's one trick to remember with any pull-type starter on a Mule or on a chain-saw or anything else. That is to pull easy on that cable until you know that it has fully and firmly engaged the dogs. You ease out on the cable till you feel a stout pull, then you give your yank to start the engine. If you just jerk and pull on it, you batter the starting dogs and you may tear up the starter. Never let go of the starting cable handle after you pull it forward—rapid rewind by the starter sheave could cause the cable to snap or break.

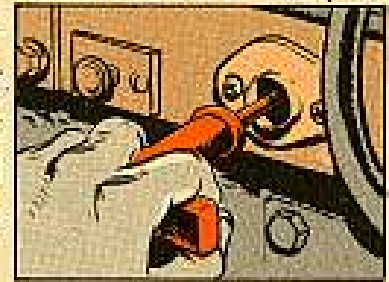

Once your engine takes off o'course, you close the choke, adjust the hand throttle as it warms and close the hand throttle for idle.



Put the auxiliary shift lever forward for high-range, depress your clutch, engage your conventional transmission in low gear and drive off—same as any other vehicle.

You operate in high-range, of course, on good roads, or good trails. But if you find you have steep hills or extremely rough terrain to cross, stop, shift to low-range, take off again in the low ranges using your conventional transmission through low, second and high, same as before. To stop, it's the same as any vehicle. You slack off your throttle, apply your brake, declutch, shift to neutral and, if you park the vehicle, set the hand brake. At which time you can reach under and shut off the ignition switch.

That's all there is to it for safe cross-country operation. But when you encounter either extreme rough cross-country or enemy fire then you'll want to get down off the vehicle and operate it from the ground.



To do this, you release the latch on the steering wheel brace

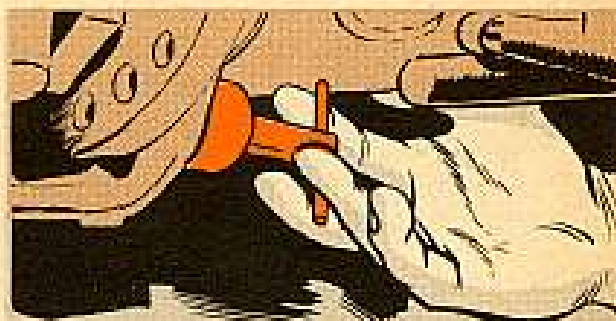

and the lock pin in the steering gear box.

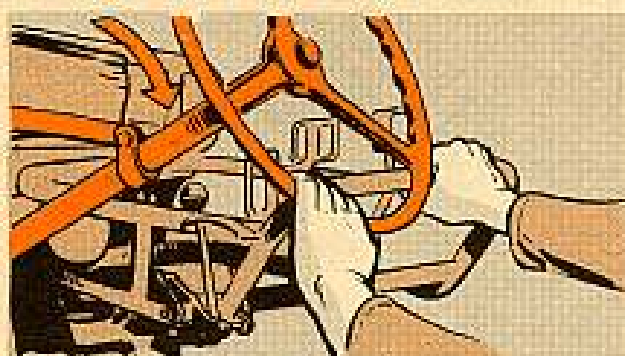

Put the wheel over forward

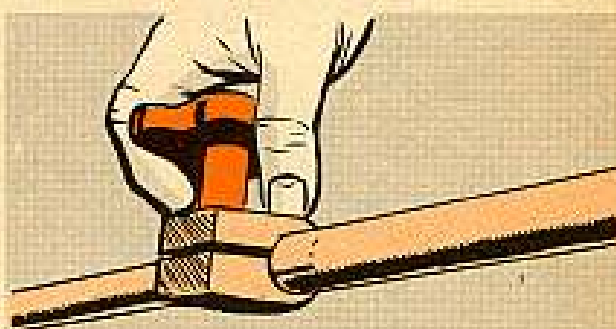

and latch it.

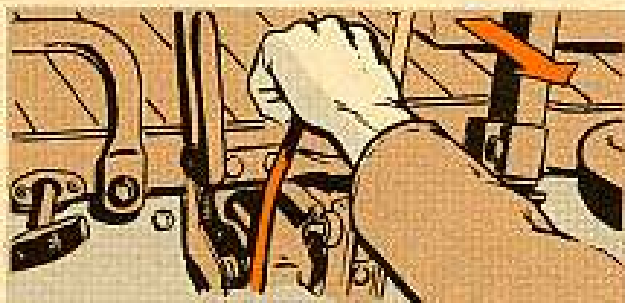

Then shift the vehicle into low-range—that is, bring your auxiliary shift lever to the back position.

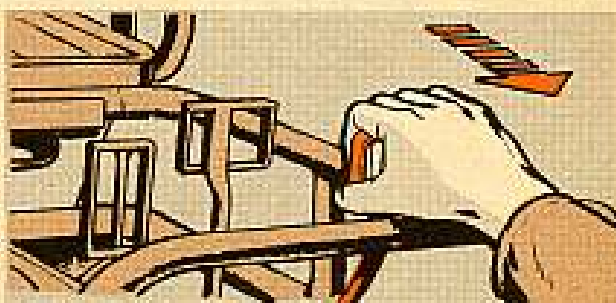

Now when you come to engage the main transmission, you'll have to squeeze the clutch pedal down by hand...

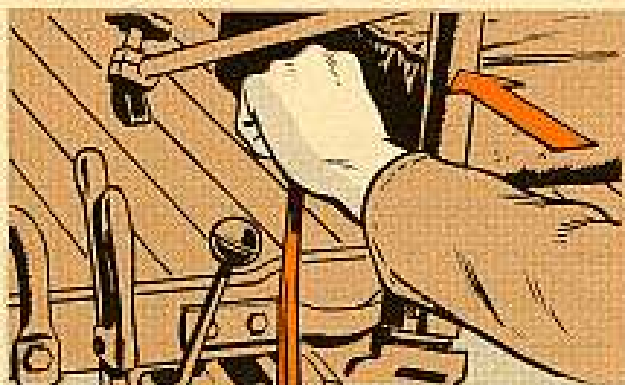

and put your main transmission in reverse.

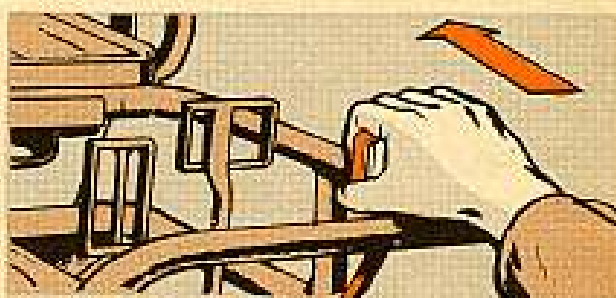

Then release clutch slowly.

Being in low-range and in reverse, the vehicle will move as slow as 4-MPH so it'll start off easy and you can walk right along behind following it. You set your speed by your hand throttle. You can duck as far as the situation requires, and you can steer from the position you're now walking in. If the territory is going to call for extremely sharp turns, if you've got rough ground—lots of trees, rocks, and so on—you can put the vehicle into four-wheel steer.

To do this, stop the vehicle and open the small plate on the platform which is located just to the right and behind the seat.

In there you'll find the steering clevis for the rear wheels—it's on a long rod and it's hooked up to a bracket on the right hand frame member. Pull a lock pin out of that clevis pin, pull the clevis pin out of the bracket, and move the rear wheel steering rod over 'til you can put the clevis pin back through that hole on the front wheel steering bell crank. Be sure to seat the clevis pin firmly home and put the lock pin in again.

You're now in four-wheel steer. Which means your rear wheels will turn in the opposite direction from your front wheels and the vehicle'll practically turn on a dime.

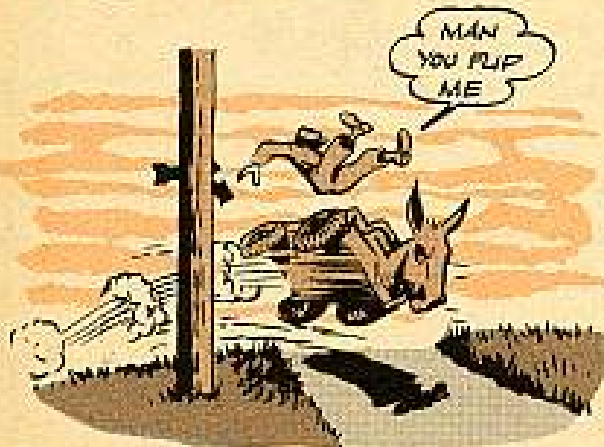
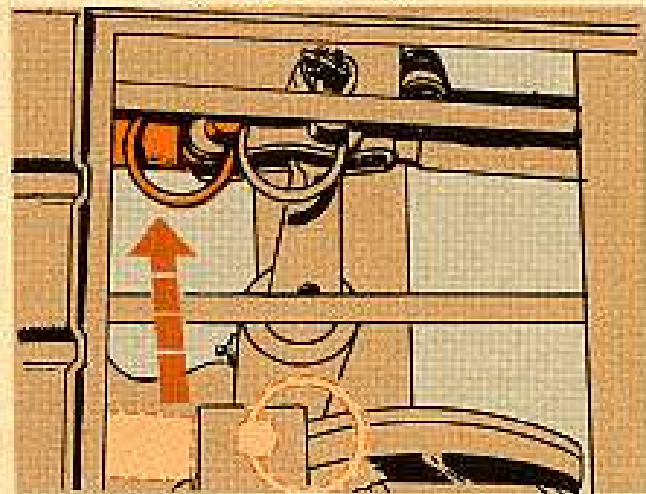
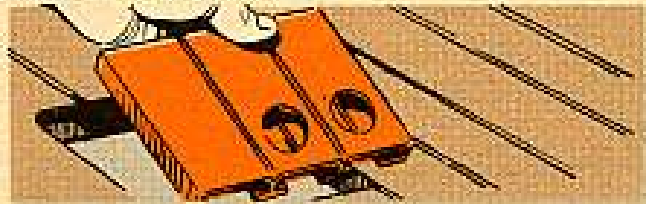

CAREFUL—One thing you've got to remember. This vehicle has only one brake drum. It's located on the front-axle power input, and it's the only brake on the vehicle. This brake is adequate and'll give you control and stop you safely in any but the wildest kind of driving. However, you do want to use your gears for descending long grades. Shift clear down to low in the transmission and, if necessary, into low-range. Descend your grades in gear to save wear on the brake drum. Then when you need the brakes you'll have 'em.

You can also use four-wheel steer when driving from the driver's seat if the condition of the terrain requires a sharp turning radius. Now, be careful not to drive too fast in four-wheel steer and not to leave the vehicle in four-wheel steer when you know you're going to be driving fast, because you'll find it's extremely responsive and you might flip it.



COLD WEATHER-



In temperatures from 40° F to -10° F you refill your engine crankcase with OE 10. In temperatures from 0° F to -65° F you refill your crankcase with OES. In addition, of course, you'll change lubrication according to the lube order. That's the only change you make for cold weather.

HOT WEATHER-



No special treatment for hot weather. Use OE 30 for all temperatures above freezing.

DUSTY OPERATIONS-

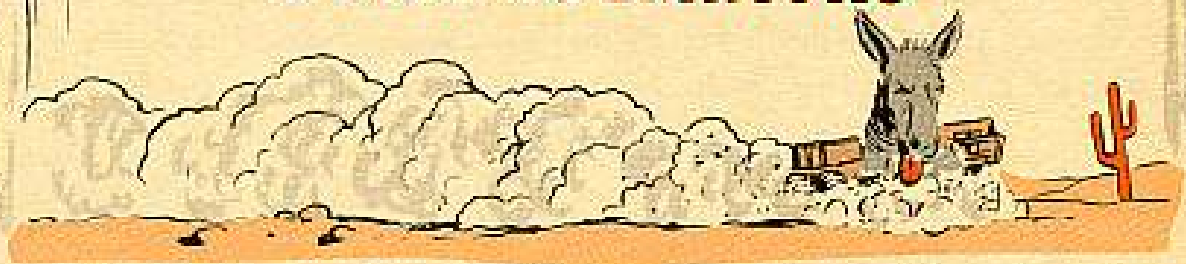

For operation under extremely dusty or sandy conditions the only special precaution you've got to take is to keep checking your engine oil level and keep your air cleaner clean. Clean and refill your air cleaner daily or oftener if it needs it.

LUBRICATION-

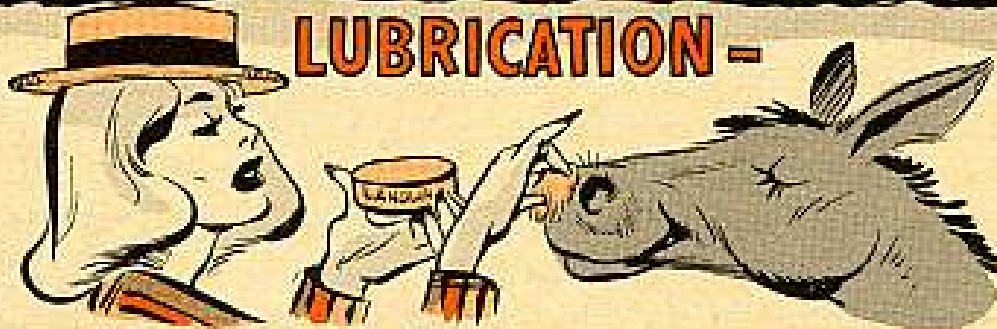

Daily: The only daily lubrication needed is to check the engine oil level and be sure the air cleaner is filled to its bead level with the same oil you are using in the crankcase.

Weekly: Check lubricant level in front axle, rear axle, transmission, steering gearbox, drop gears, steering knuckles and wheel bearings. Grease universal joint. Clean the rain-deflector/pre-cleaner (take it off and wash it in solvent). Use your oil can (with PL) on the brake, clutch and throttle cables and disconnects, the hand throttle, the shifting control rods and brackets, the steering locking and sector joint, the storage clips and access door locks, the tow bar clamp screw, the steering column brace, the tow bar bell-crank and the tow bar drag link.



Monthly: Check and clean the crankcase breather. Lubricate tie rod sockets, drag link sockets, U-joints, steering connecting rod, brake linkage, clutch linkage, shifting linkage, pedals, etc. In fact, all the grease fittings.

160 hour: Crankcase draining is done on the basis of operating hours, 160 of 'em to be exact. Drain while the engine is hot, and clean and inspect the oil filter at the same time. Also take off the sump (oil-pan) and clean it. Refill to the full mark, then run the engine a few minutes and check oil level again, adding a little oil if necessary to make up for that which went into the oil passages and oil filter housing.



Annually: On an annual service, you'll check the front axle drain (drain 'er and refill); the drop gears; the universal joints; the steering knuckles and wheel bearings fill (drain and refill); and the transmission rear axle (drain and refill 'er—she takes 2 quarts).

You've got considerable disassembly involved in getting at some of these. The clutch pilot-bearing has to be lubricated when the power pack is out of the vehicle. The chances are it'll go back to battalion maintenance or higher for the inspections.

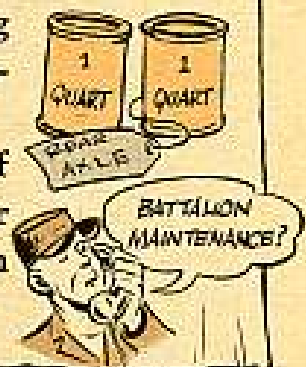

Tire pressure is 12-PSI.

Publications out on the Mule are:

- TM 9-8034-10 (for the driver);
- TM 9-8034-20 (for the mechanic);
- TM 9-8034-20P (parts list).



YOUR JEEP'S

EQUIPMENT

A tool is just a hunk of iron until you need it. Then, brother, it can be the most important thing in the world.

That's why you should keep a constant tab on the equipment on your trucks. To start you off, here's the dope for your M38 and M38A1 Jeeps.

The guide below goes for both your M38 and M38A1 Jeeps. The M38 carries an extra screwdriver and different publications—but with these exceptions, the stuff you carry on both Jeeps is the same.

You may find that the FSN's given here are different from those in your SNL's. These numbers were taken right from the latest supply manual on tools (SM 9-1-5100).

Not all the equipment shown here comes as OVM. Some is authorized by your Table of Organization and Equipment or Table of Allowances or by other supply authorities. Check your vehicle's SNL's closely for the difference.

THIS IS THE LATEST POOP



M38A1

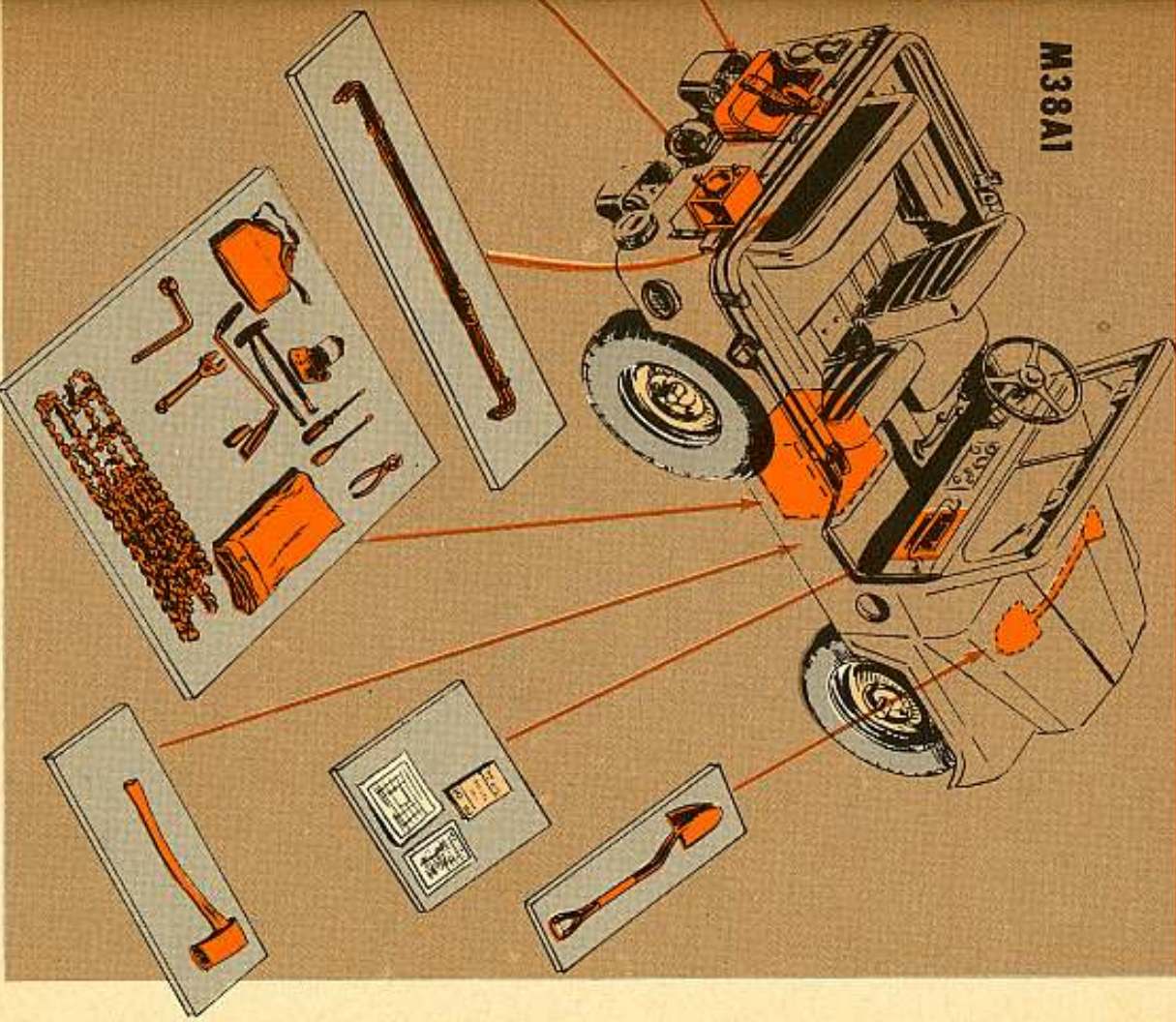

M38

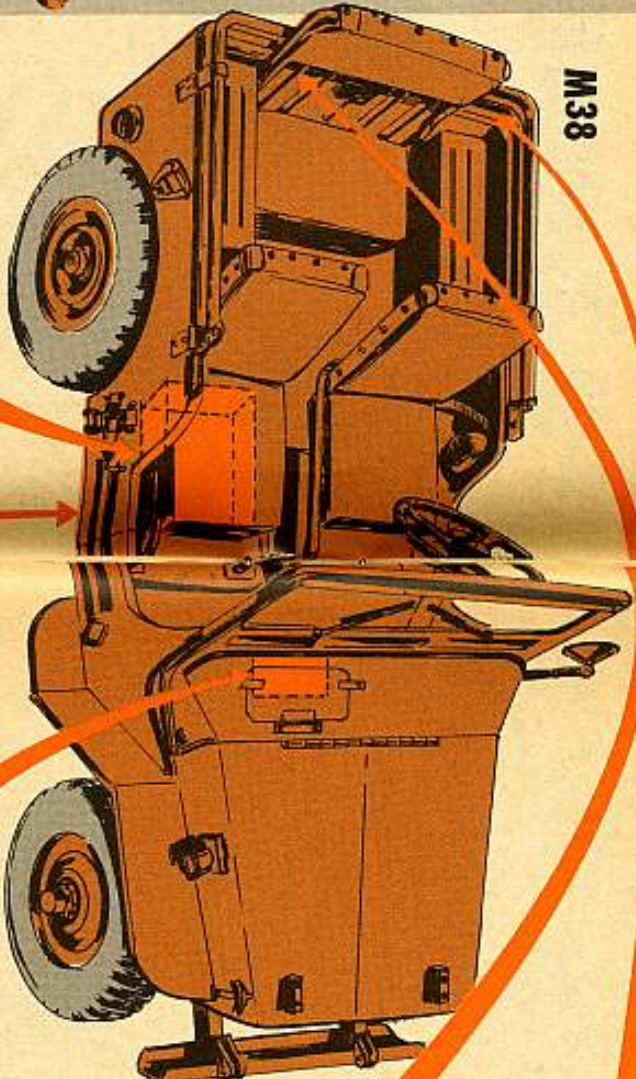

BAG, TOOL, empty, 20 1/4 x 18 1/4 in to top of flap, open.



FSN 5140-772-4142
1 auth
Tool compartment

PLIERS, SLIP JOINT: slight nose, comb, w/ cutter, 8 in lg.



FSN 5120-223-7397
1 auth
Tool compartment

SCREWDRIVER, FLAT TIP: mtl w/ wood inserts hd, flared tip, 3/8 in w, 6 in lg blade.



FSN 5120-227-7349
1 auth
Tool compartment

SCREWDRIVER, FLAT TIP: wood hd, flared tip, 1/2 in w, 4 in lg blade (M38 only).



FSN 5120-277-9491
1 auth
Tool compartment

JACK, SCREW HAND: geared, upright, 1 1/2 ton cap, 7 3/4 in closed h, 15 3/4 in extended h, w/o xtn cap.



FSN 5120-244-3314
1 auth
Tool compartment

WRENCH, WHEEL STUD NUT: sgle hd, offset socket, hex, 3/4 in opng, 9 1/4 in lg.



FSN 5120-422-8803
1 auth
Tool compartment

WRENCH, OPEN END, ADJUSTABLE: sgle end, 3/4 in jaw cong, 8 in lg.



FSN 5120-240-5328
1 auth
Tool compartment

WRENCH, PLUG, STRAIGHT BAR: sq 1/2 in plug, 2 1/2 in lg.



FSN 5120-708-3302
1 auth
Tool compartment

CHAIN, ASSEMBLY, TIRE: single, 7.00-16 and 7.50-15, type P.



FSN 2540-054-0044
{See SB9-99 for basis of issue.}
Tool compartment.

COVER, TOP: w/ rear curtain (M38).



FSN 2510-769-7412
1 auth (This is a component of vehicle, not OVM.)
When not in use, in tool compartment.

COVER, TOP: w/ rear curtain (M38A1).

FSN 2510-040-2558
1 auth (This is a component of vehicle, not OVM.)
When not in use, in tool compartment.

BOW, VEHICULAR TOP: front and rear.



FSN 2510-737-2809
1 auth (This is a component of vehicle, not OVM.)
When not in use, in back of rear seat.

WHEEL, PNEUMATIC TIRE



FSN 2530-287-2314
1 auth
On spare tire carrier

TIRE, PNEUMATIC: 6-ply rating, light truck, cross-country tread, w/controlled bead, 7.00-16.



FSN 2610-289-9586
1 auth
On spare tire carrier

INNER TUBE, PNEUMATIC TIRE: truck and bus, 6.50/7.00-16.



FSN 2610-289-7332
1 auth
On spare tire carrier

CAN, GASOLINE, MILITARY: MIL-C-1283A.



FSN 7240-222-3088
(If issued, TOE or TA was authority.)
In gasoline can bracket



SHOVEL, HAND: rd point, Ref Dwg Group 60, section A, style 1; D-handle; commercial size no. 2; blade, 11 1/2 to 12 1/2 in lg, 9 1/2 to 10 1/4 in w, open back; no special features; Fed GGG-S-326, type W, Class A, style 1.

FSN 5120-250-1499
(If issued, TOE or TA was authority.)
*Side of vehicle

In motor pool



DA Form 478

LUBE ORDER



TM 9-8014 (M38A1)
In glove compartment

TM 9-8012 (M38)



AX, SINGLE BIT: 4 3/4 in w/cutting edge; 4 lb wt of head; 36 in lg handle; not rated non-sparking and non-magnetic; no special features; Fed GGG-A-926, type 1.

FSN 5110-222-0455
(If issued, TOE or TA was authority.)
Side of vehicle

EQUIPMENT STORAGE ON—

YOUR G741 3/4 -

Here's another rundown on your vehicle's equipment—this time on the G741-series 3/4-ton trucks. It spells out the right names, the FSN's and where you carry the stuff on your vehicle.

Again, not all the equipment shown here comes as OVM. Some is authorized by your Table of Organization and Equipment or Table of Allowances or by other supply authorities. Check your vehicle's SNL's closely for the difference.

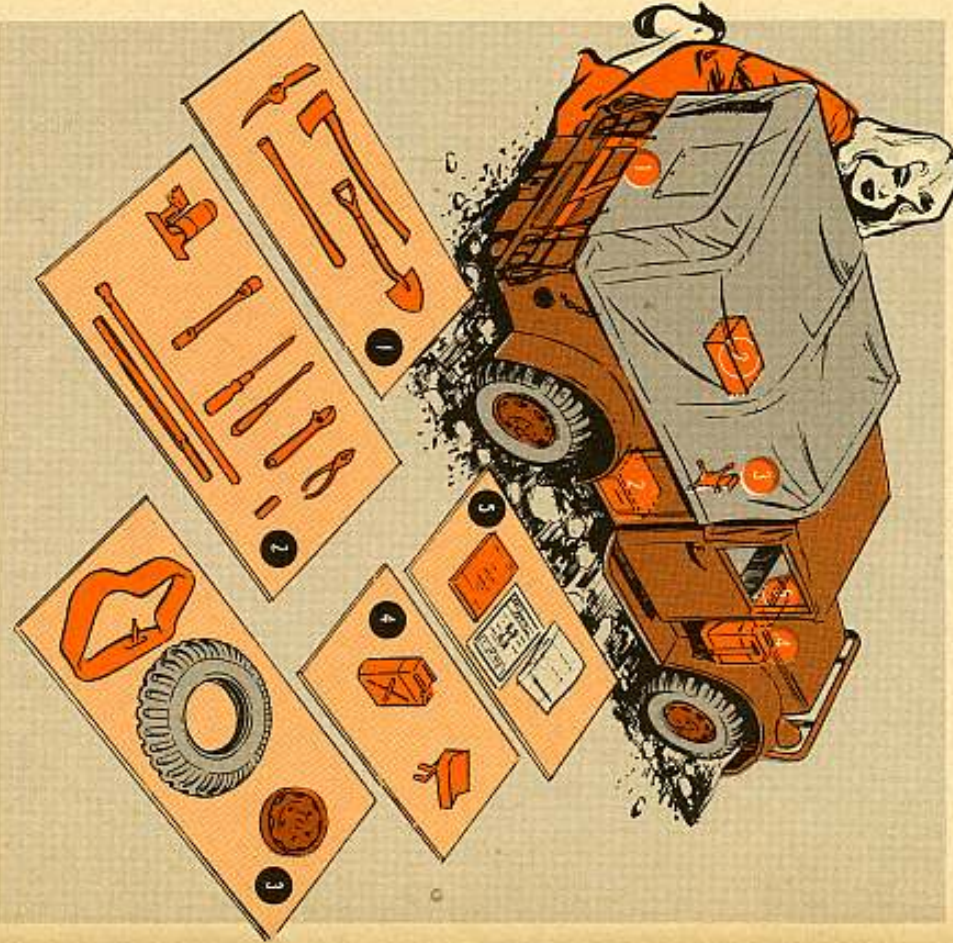

TON TRUCK



Your G741 has two tool compartments—one on each side of the vehicle, just to the fore end of the rear fender. Divvy up those tools equally between the tool compartments, so nothing is jammed up. There's plenty of room.

The equipment for your G741 may include pioneer tools. If you have 'em, they're kept in the pioneer tool rack, which is fastened to the vehicle's tail gate.

HERE'S HOW THAT G741 OVM STACKS UP—

<p>BRACKET, TOOL: pioneer equip set (motor vehicle) for M37 and M42 only. FSN 5120-357-5494</p>		<p>(if pioneer tool set is issue, TOE or TA was authority.) SHOVEL, HAND: rd point, Ref Dwg Group 60, section A, style 1; D-handle, commercial size no. 2; Blade, 11½ to 12½ in lg, 9½ to 10½ in w, open back; no special features; Fed GGG-S-326, type IV, class A, style 1. FSN 5120-250-1499</p>	
<p>HANDLE, MATTOCK, PICK: 36 in overall lg; railroad or clay pick; no special features; Fed NN-H-93, grade AA. FSN 5120-254-6618</p>		<p>Pioneer tool rack</p>	
<p>MATTOCK, pick type: Fed GGG-H-506, type II, class F; w/o handle; 5 lb size; no special features. FSN 5120-243-2395</p>		<p>Pioneer tool rack</p>	
<p>AX, SINGLE BIT: 4¾ in w/cutting edge; 4 lb wt of head; 36 in lg handle; not rated non-sparking and non-magnetic; no special features; Fed GGG-A-926, type I. FSN 5110-222-0455</p>		<p>Pioneer tool rack</p>	



BAG, TOOL, EMPTY, 20 1/2 x 18 1/2 in to top of flap, open.

FSN 5140-7724-142

1 auth
Tool compartment



PLIERS, SLIP JOINT; slight nose, comb. w/ cutter, 8 in lg.

FSN 5120-223-797

1 auth
In tool bag



SCREWDRIVER, FLAT TIP; mtl w/wood inserts hnd; flared tip, 3/4 in w, 6 in lg blade.

FSN 5120-227-7349

1 auth
In tool bag



SCREWDRIVER, CROSS TIP; Phillips No. 3 tip, wood hnd, 6 in lg blade.

FSN 5120-293-3346

1 auth
In tool bag



WRENCH, OPEN END, ADJUSTABLE; sigle end, 1/4 in jaw o/png, 8 in lg.

FSN 5120-240-5328

1 auth
In tool bag



WRENCH, PLUG, STRAIGHT BAR; sq 1/2 in plug, 2 1/2 in lg.

FSN 5120-708-3302

1 auth
In tool bag

LUBE ORDER



TM 9-8030

In glove compartment



JACK, HYDRAULIC, HAND; self-contained, 3 ton cap, 9 1/4 in closed h, 15 1/4 in extended h, sigle pump, w/ screw extn.

FSN 5120-233-6829

1 auth
Tool compartment



CAN, GASOLINE, MILITARY, MIL-C-1283A

FSN 7240-222-3088

(If issued, TOE or TA was authority)
In gasoline can bracket



BRACKET, DRUM, for inflammable liquid, S, welded, w/ strap.

FSN 8110-473-6331

1 auth
Bolted to right front fender



TIRE, PNEUMATIC; Truck and bus, 8 ply, mud and snow tread, 9.00-16.

FSN 2610-051-1700

1 auth
On spare tire carrier



TUBE, PNEUMATIC; Truck and bus, 9.00-16.

FSN 2610-051-9265

1 auth
On spare tire carrier



WHEEL, PNEUMATIC; TIRE

FSN 2530-738-8452

1 auth
On spare tire carrier



BAR, SOCKET WRENCH HANDLE; 3/4 in dia, 30 in overall lg.

FSN 5120-243-2419

1 auth
Tool compartment



WRENCH, SOCKET; wheel stud nut, I, dble, 1 3/4 and 1 1/2 in hex openings, 11 3/4 in overall lg.

FSN 5120-293-2452

1 auth
Tool compartment

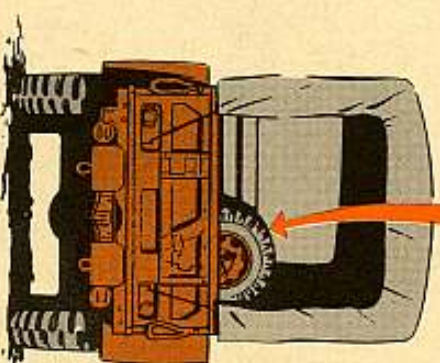

DA Form 478

In motor pool

TANK TALK

'Gas' Pains?
Bleed 'Er!



Ever have that condition that comes the morning after the night before? You don't feel good till you've taken something to get rid of that hangdog gassy feeling.

Ditto for the hydraulic system in your M48 and M48A1 tanks—every once in a while it's gotta be bled to get rid of air that's making your gun act sluggish and fizzled out.

HERE'S HOW:



1. Traverse the gun to the front of the tank hull so the gun's automatic elevator circuit won't foul up the bleeding procedure.



3. Turn the turret power switch ON and elevate and depress the gun through its full arc of travel three times. 'V' can use either the manual elevating control handle or the gunner's power control handle.



2. Check the oil level on the dipstick in the power-pneck oil reservoir. You'll find it on the turret floor directly behind the gunner's seat. Make sure the oil level is at the FULL mark; if it isn't, add oil.



4. Turn the turret power OFF and check the oil level in the power-pneck reservoir again. Add more oil if necessary to bring the level to FULL.

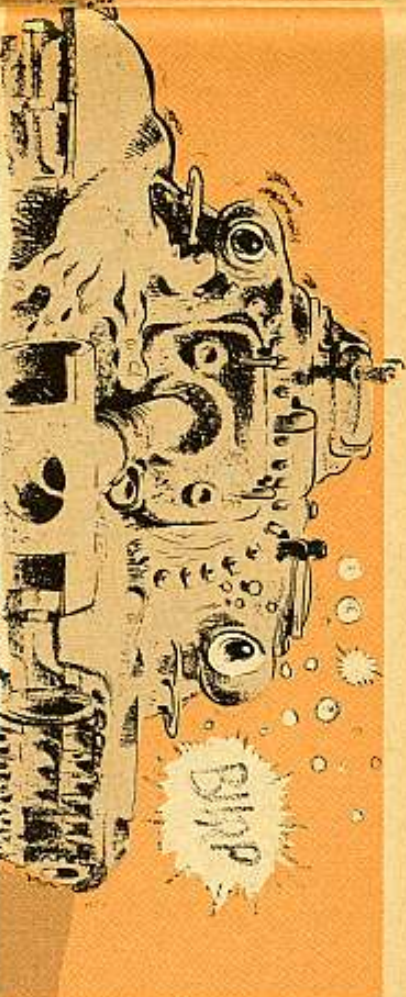

5. Just crack both bleeder plugs located atop the front and rear flange housings of the elevating mechanism cylinder. An $1/8$ -in. open-end wrench'll do the trick. (Careful—you don't want to loosen that plug too much or you'll think you've struck oil.)

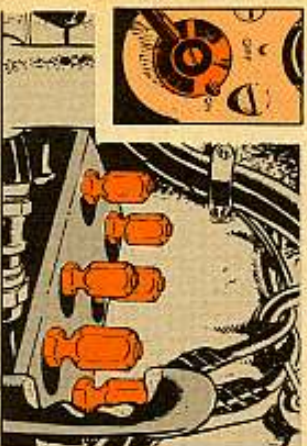

7. Leaving the turret power ON, bleed the remaining elevating system lines by using the bleeder valves on the anchor plate, located on the forward turret wall below the elevating hand pump. Loosen each plug (here you'll use a $5/8$ -in. wrench), bleed the air, retighten the plug and go on to the next one.

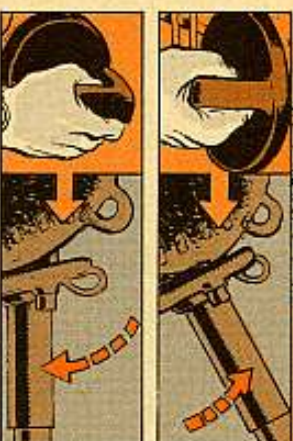

6. Turn the turret power ON and slowly elevate and depress the gun in power until the oil no longer looks foamy—when it's clear red, and flowing smoothly, you'll know all the air is out. Unhand the gunner's control and tighten the plugs.

For the left rear plug (looking at the anchor plate from the gunner's position) after loosening it, work the accumulator pump handle to bleed it.



For the center front and rear plugs, use the manual-elevating control handle.

For the right front and rear plugs, use the gunner's power control handle.

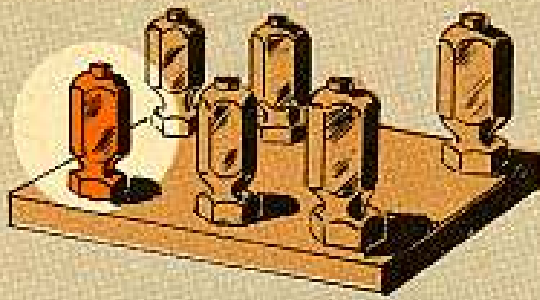

8. The left front plug is the drain line, so you don't have to touch that one.

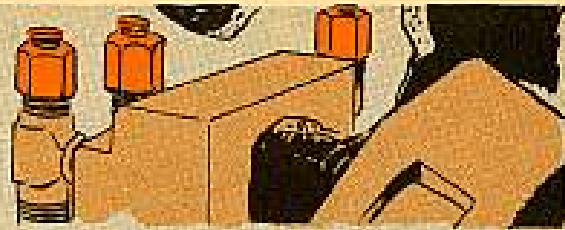

9. If you take a squint in back of the gunner's control handle assembly, you'll see a bleeder cap on each of the three tees leading from the valves on the manual elevating control handle. To bleed these lines, open each of the caps slowly, one at a time, rotate the elevating hand pump to bleed, and retighten the caps.

10. When you're all through, turn OFF the power-pack and refill the power-pack oil reservoir to FULL. Elevate and depress the gun several times using both power and manual controls. If the gun still doesn't feel rigid, bleed the system again.

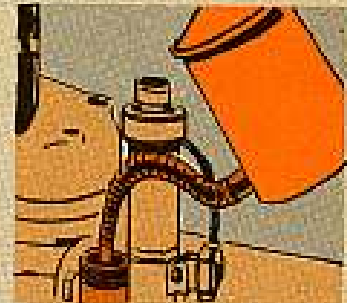
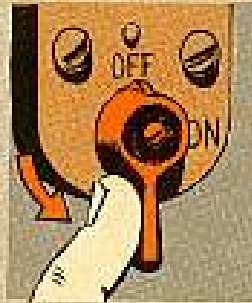

The Right Tool

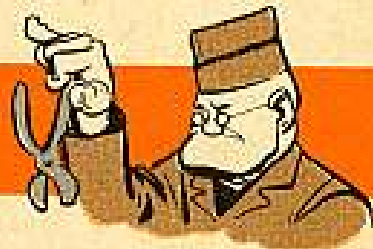

Next time you want to turn your 895 engines at the accessory end, don't do it the hard way, using makeshift tools. There's a tool in the system just made for the job.

It's found in Set B, Special Tool Set, Organizational Maintenance, and goes by the name of Wrench, socket, engine turning, splined type (28 int splines) $\frac{3}{4}$ -in female sq drive, $1\frac{7}{8}$ -in OD, 2-in lg, FSN 5120-310-4673.

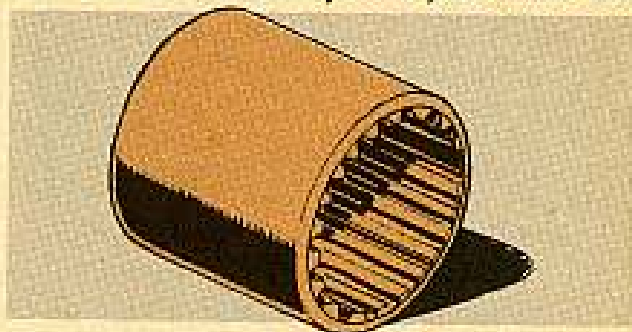

You can use it for all your vehicles that have an AO- or AOS-895 engine.

You don't have to order the whole tool set to get the wrench, either. You're authorized to order the wrench by itself—just take a peek at your vehicle's Ord 7. You'll find the wrench listed under "Organizational Tools and Equipment."

Safety First

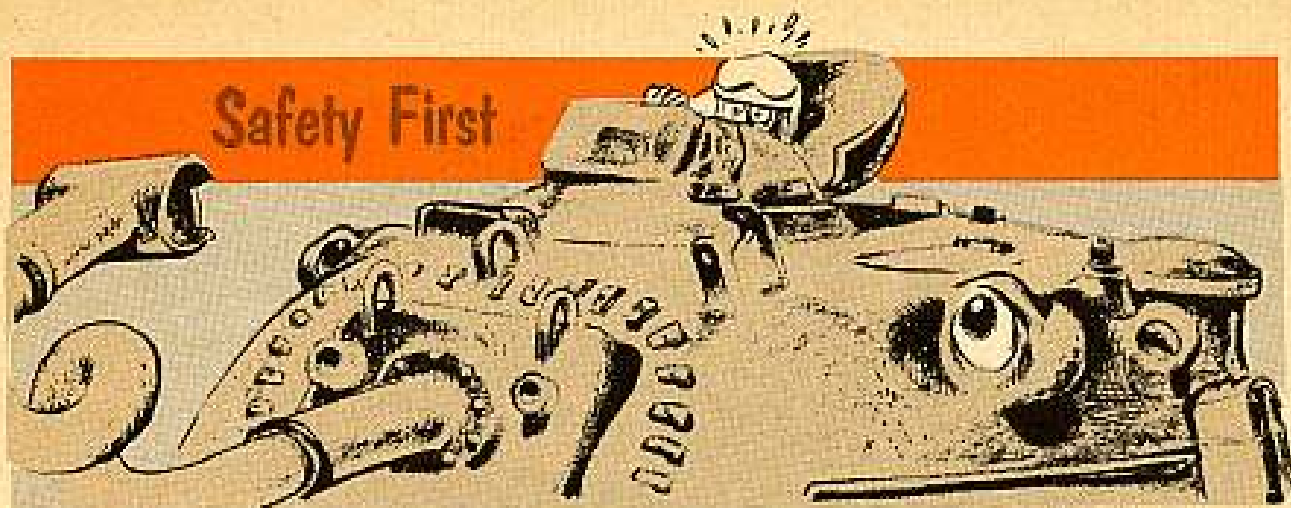

Yup. That's what the rule is no matter where you are, and it holds doubly true when you're ready to operate the hand firing lever on the 90-mm gun in your M48-series tanks. You gotta make sure that the safety lever's flipped off 'fore you fire your weapon.

A couple of slow Joes forgot all about that lever during practice t'other day. Result? They yanked hard on the hand firing lever while the safety lever was still on. Ended up with a broken hand firing mechanism bracket, which did 'em no good at all.

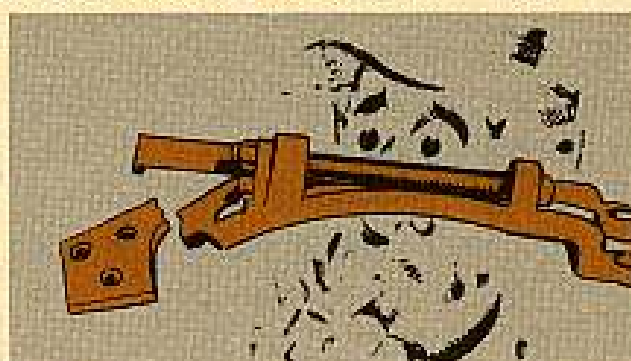

The pressure you put on the firing lever is supposed to turn your hand firing shaft, but when the safety lever's on, all that pressure goes to the bracket instead, and something's got to give.

So make **Safety First** your own rule . . . for keeps. Check your safety lever to be sure it's flipped toward the rear 'fore you fire.

Missing Gaskets

Been wonderin' what gaskets to get for sealing the main air cleaner body to the oil reservoir (cup) on the M46-series, M47, and M48-series tanks?

If you've got a Vortex air cleaner on 'em now, get Gasket, FSN 5330-282-6156 (G274). If you've got the Donaldson on 'em, then get Gasket, FSN 2940-563-4463 (G251).

Won't be any trouble gettin' 'em through regular supply channels, so order now. Be sure to get the right gaskets for the right cleaner.



O'MIGOSH,
I DIDN'T...

Put It Back Right



Next time you're helping your support unit replace the final drive in your M47 tank, make sure you remove the whole final drive, 'stead o' just taking off the end cover. With that end cover off, it's real easy to start fiddlin' around with the gears and shafts inside, and first thing you know, you may be holding that final drive pinion in your hand, wonderin' where it came from.



And, what's worse, you may be tempted to put it back . . . the wrong way. Y'see, the final drive pinion is counterbored at the end that's toward the transmission, so's the final drive in-input shaft will fit into it.

Don't be fooled, either, thinkin' that you couldn't put it in wrong, 'cause it'll fit either way. Only thing is, you'll burn up the whole final drive if you put it in backwards.

So, don't take chances—if you see that final drive pinion out of the final drive, mark the counterbored end some way so's the next guy'll know it goes toward the transmission.

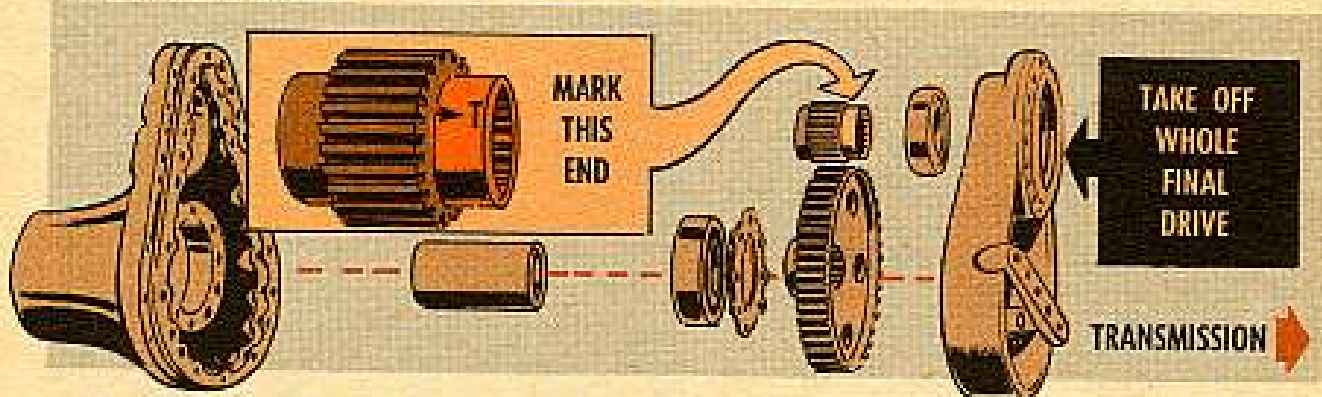

By the way, TB Ord 546 (9 Dec 53) gives you some worthwhile dope on final drives, which'll be of use when you help your support unit do a job on this part.

Connie Rodd's

"SHORT 'N SWEET DEPT"

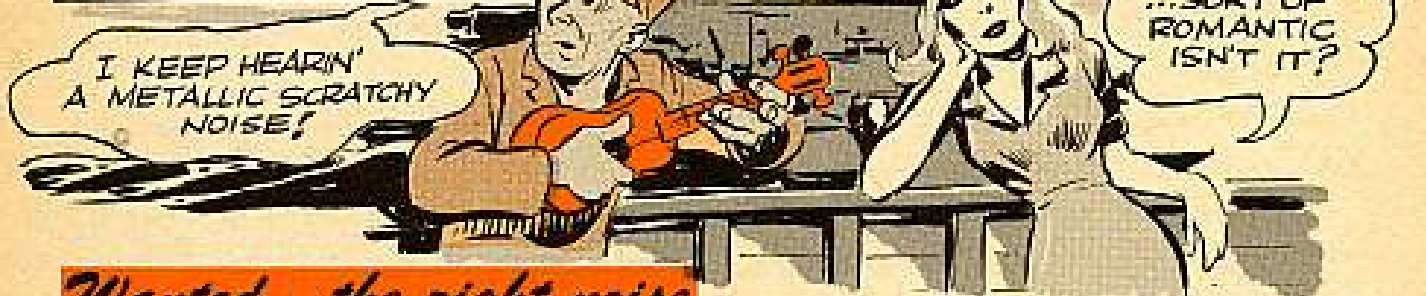

Wanted...the right noise

On your M42 twin 40-mm motor carriages and your M41A1 tanks—if you hear a metallic scratchy noise coming from your Li'l Joe's fuel-line quick-disconnect coupler assembly when you're connecting or disconnecting it, you want it there—and, then again, maybe you don't.



On your M42's after serial number 1385 and on your M41A1's after serial number 3589, a new type of fuel-line quick-disconnect coupler assembly (FSN 2910-620-0932) was put in. When connecting or disconnecting this coupler, you'll hear that metallic scratchy noise. Don't let it worry you—you want it there.

Now, on those M41A1's below serial number 3589 and on those M42's below serial number 1385, you have an older

style coupler assembly, FSN 4730-738-8570. When connecting or disconnecting with this one, you should hear no noise. If there is noise, you'll know that there's lots of dirt and grit around that assembly and it needs cleaning out, before it starts freezing on you.

MWO to a "T"

There's nothing better for trouble than plowing ahead into a job without first giving the how's, what's, and where's, a good going over.

And that goes double when you're getting ready to apply MWO's or TM 1 changes to any piece of equipment. Not looking before you leap is a good way to botch up things.

So, keep two jumps ahead of your next move...study that MWO or TM 1



until you really understand it...and please, don't make with the shortcuts.

Messin' around

So, you can't get yourself some of those vehicle classification signs called out in FM 5-36 (April 55), "Route Reconnaissance and Classification?" Well, that's OK—because you can make your own.

Just meander over to your mess hall and see if you can find a few tin can bottoms lying around, either 9 inches in diameter or a little bigger. If the lids are bigger, you just cut 'em down to that 9-in size.

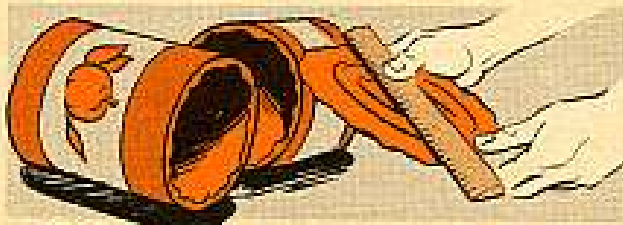

Before you paint 'em up, it'd be a good idea to file or stone the edges of the lid 'cause they can be cutting-sharp and



wicked. Then you just paint the background of the sign with yellow paint and use black paint for the numerals.



If you can't scrounge the cans, make your sign from any piece of flat sheet metal or a piece of plywood.

Para 33 of FM 5-36 and its Change 1 gives you some good clues on making these signs. Para 36 of the FM tells you which classification number you want for your vehicle.

As far as issue vehicle classification signs go—they're on the way, but so far they're not ready for issue. So, don't bother with requisitions until you're given the go-ahead.

MPH: KmPH

Remember back to your high school algebra days when $x + y$ used to equal z ? Thought those days were gone forever when you waved goo'by to your ol' alma mater? Not so, brother, not so.

Although it isn't real tough trying to get Km (kilometers) translated into MPH (miles per hour) it can be one pain in the neck. So, the Army's done it for you, and here's the story.

MPH	KmPH	MPH	KmPH
10	16	40	64
20	32	50	80
30	48	60	96

Notice from this table that for every 10 miles you travel, you're actually going 16 kilometers. For example, if you travel 20 miles you've come 32 kilometers. Figuring still further, you can see that 1 mile is the same as 1.6 kilometers.

It'd be a good idea to put that MPH-KmPH table on some gummed paper and stick it on your vehicle's dashboard near the speedometer. That way a quick glance will tell you right off how many kilometers you've covered in how many miles.

Of course, this only goes for you guys who are stationed in countries where they use kilometers 'stead of miles.

How's your lead



Check the ignition wires on your AV 1790 and AO-895 combat vehicle engines, will you? They could be heading for a breakdown if they're the wrong ones.

You see, there have been two lead assemblies put into the supply system under FSN 2920-732-4011 (G244). One's good and the other's no good. The good one has a spark plug sleeve made of a ceramic material. The other one's sleeve is a rubber-like material. Another tip-off to a bad cable is that it's too long, which causes it to kink and short against the cable shielding.



If you have any leads with this rubber-like sleeve—replace them. When you get new ones from supply make sure you don't get the rubber-like material one. Tell 'em you need the ceramic-type lead. Or, failing that, replace the rubber jobs with the ceramic ones whenever you can get your mitts on some.

Headlight clue

Ord 7 SNL G258 (June 1955) page 45 for your M52 105-mm self-propelled howitzer, says this 'bout Headlight, Service Assembly: "Use Headlight FSN 6220-776-5212 (G251) until depleted, then use Headlight FSN 6220-741-9686 (G260)"—the new one.

If you get the new one for some of your vehicles, you'll be thrown for a loss. The brush guard assembly, mounting, and wiring are different, so the secret's to get the right light for the right vehicles.

To clue you in when orderin' your next batch of lights, the only way you're sure to get the right one is to give the serial numbers of the vehicles you are orderin' for.

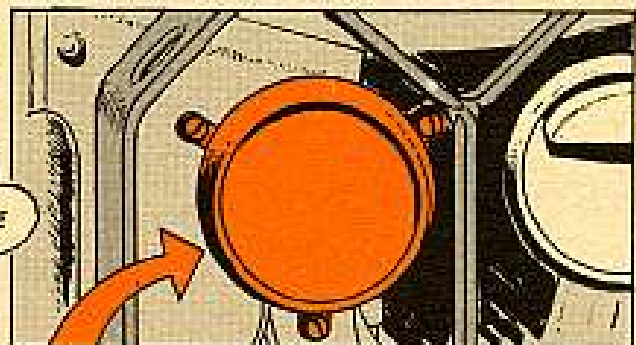

All vehicles through serial number 466'll get Headlight FSN 6220-776-5212 (G251).

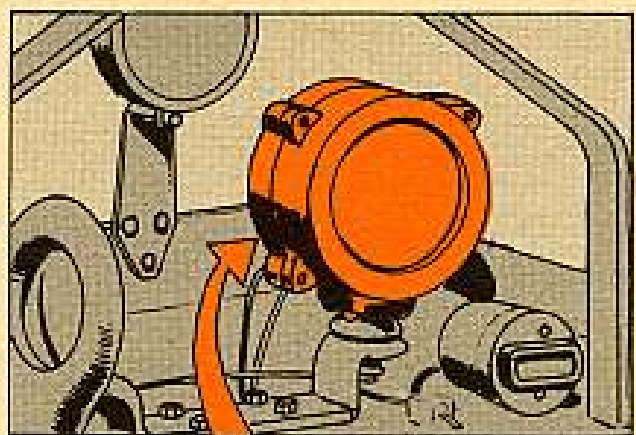

After serial number 466 they'll get Headlight FSN 6220-741-9686 (G260).

Touchin' 'em off

Any unit with a Model 632 GMC 5-ton commercial truck-tractor with contract number DA-20-113-22575 tacked on it, better get the fifth wheel operation lever fixed up pronto. And don't go hookin' up any semis till you do.

The lever has a 30° (downward pitch) angle in it that, when making a turn—or when the fifth wheel portion is lower than the front of the tractor and the rear of the trailer—hits the base of the fifth wheel and releases the load.

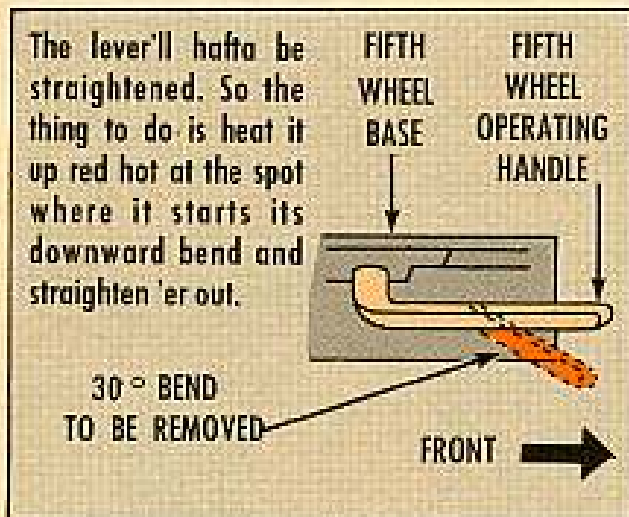

This done, you can now look back knowing your load will still be with you.

Checkers, Anybody?

The only batteries that'll fit in your G749-series 2½-ton trucks—the way the battery retainer's set up now—are your Delcos. For all other batteries, you're going to have to do a little finagling.

And, it may be sooner than you think, because many Exide and Willard batteries are on their way. When you go to put these batteries into the

truck, you'll find that you can't tie down the battery retainer because of the checker-board arrangement of the battery vent caps.

So, you have to follow the dope given in TM 9-8024 (Oct 55) on page 291 and in Fig 155.

All you do is measure over 1¼ inch from where the battery tie-down bolts were originally placed and drill two ¾-in holes.

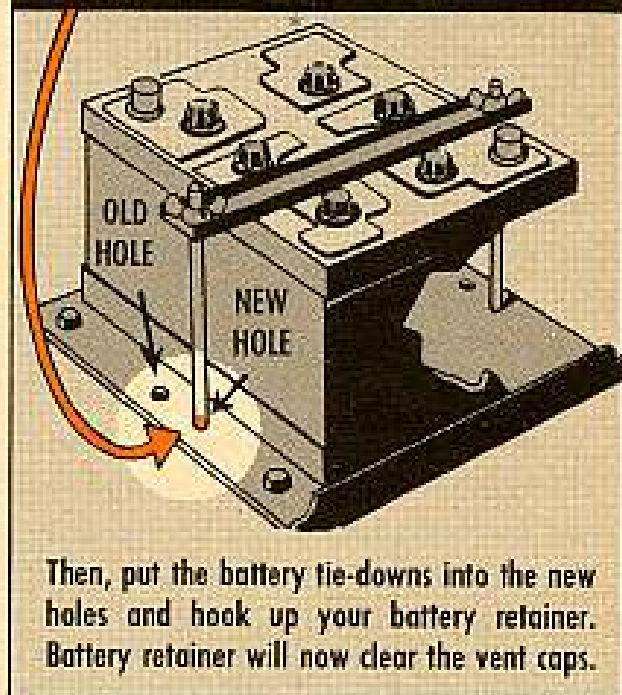

Better check first before doing this job—it may already be on the truck. You can check your 478 jacket file or look at the truck to see if TB 9-819A-9 or the instructions in TM 9-8024 were applied. This TB gave the instructions before TM 9-8024 was published. The TM picked up the dope and superseded the TB.

Clickity-clackity end

You hearin' a clicking noise from the rear end of your M38 or M38A1 Jeep? Before you run that truck back to support with a cry of "bad rear," check one thing out first.

Achin' mains

If that axle nut is loose, the rear-axle-shaft key'll be loose and click itself against the wheel hub. So, tighten down on that nut and this may solve your problem.

One more bit of info about that axle-shaft key. The key has a chamfered end so it'll fit real snug with the chamfer on the rear-axle-shaft.

Now, some guys're getting things sorta fouled up when they go to reassemble their rear-wheel assemblies. Seems they're putting that key in wrong. First thing you know, the keys get mashed up—and so do the axles and bearings.

So, the way to do it is like this:

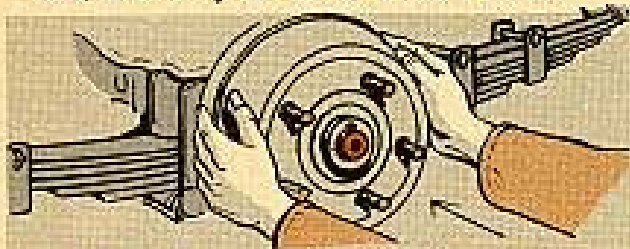

Set the hub on the axle shaft, but don't set it up all the way.



Line up the keyway in the shaft with the keyway in the hub.

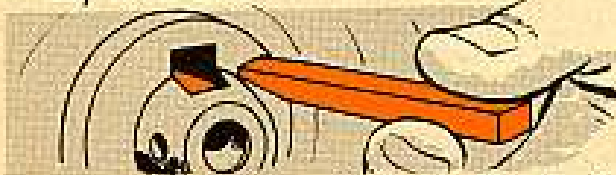

Now, put the key in with the chamfered end down. This is the end that'll go in first.

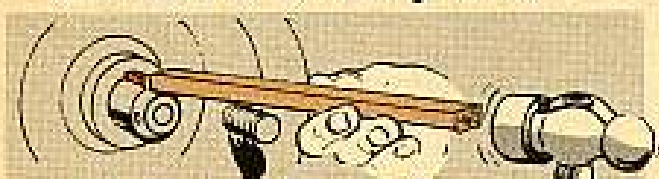

Set the key in as far as she'll go. Then, tap the hub and key into place on the shaft.

Transmission moans are being heard on some of the early production Model 424 2½-ton stake and platform trucks. The front mainshaft bearings of these transmissions are getting small pits in their cones—you'll know it when you get a whining noise from your transmission when it's in neutral and the clutch is engaged.

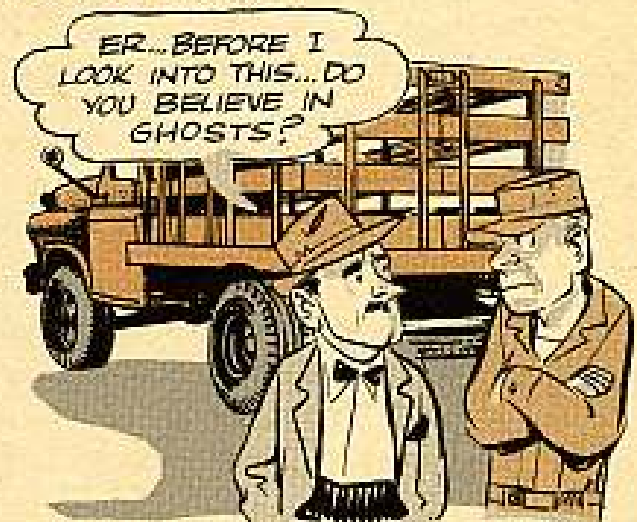

A few hundred miles after you first notice the whining and wailing, the surface of the cone starts breaking apart, and you get more noise. In time, all the other bearings in that transmission get themselves ruined by the metal chips which come flying off that mainshaft bearing. Most of these things happen after the truck gets 2000 to 3500 miles on her.

If you have yourself some of these troubles, you'd best get that truck back to support, so they can get it to the manufacturer's representative. If that transmission fouled because it didn't have enough lube in it when it came to you from the manufacturer, he'll give you a new gear box or repair the old one.

Belly bad situation

Just to keep from getting a good jab in the tummy by those rear reflectors on the ½-ton, 4x2, Chevy carry-alls or panel jobs, Models 3100-3116, better get 'em off the rear fenders and onto the rear panels of the body soonest.

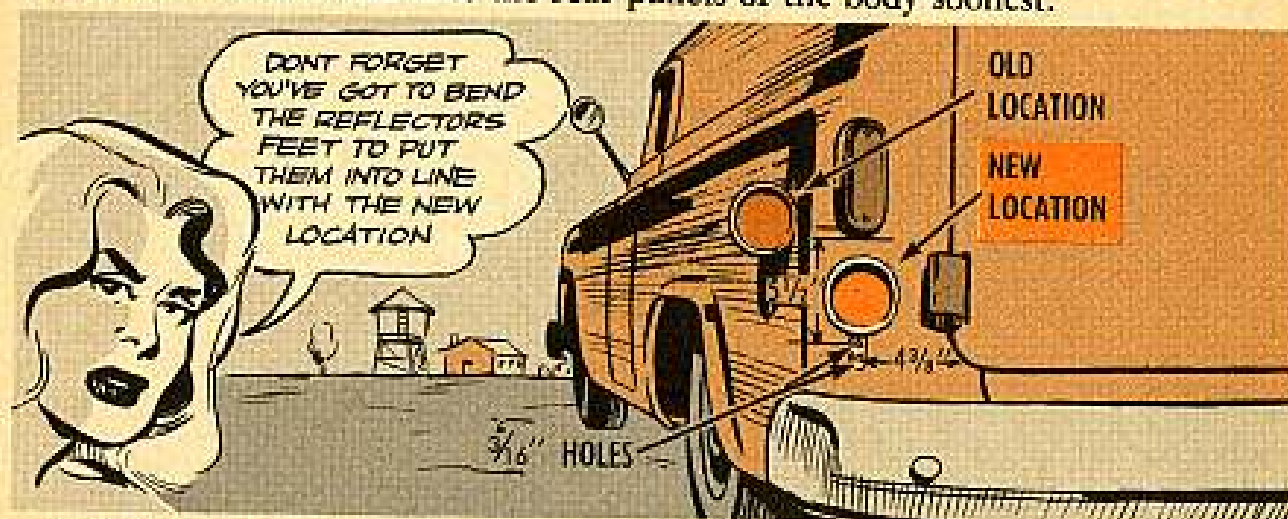

First, take the two tapping screws out of each reflector—but don't throw 'em away. Weld or lead shut the gapping holes left from the removal of the screws. Smooth off the filling, and prime and paint—like it says in TM 9-2851.

Before the reflectors can be put into their new location, their foot has to be bent out to bring 'em into line with the reflector body. To do this, put the bracket in a vise and, by pushing slowly—with most of the pushing pressure on the bracket—straighten 'er out. Be a mite careful or you may pull the bracket loose from its rivets.

Now, drill two $\frac{3}{16}$ -in holes on each side of the truck's rear panel. Drill the first hole $4\frac{3}{8}$ inches from the edge of the gate or door opening (depending on whether you have a carry-all or panel job), and $5\frac{1}{2}$ inches below the bottom of the tail light. The second hole is vertically lined up with the first hole and spaced 6 inches below the tail light. Do this on both sides of the rear panel.

Now, put the reflector's tapping screws into the holes and install the reflectors with the bracket below the reflector itself. If you've taken any of the truck's paint off, be sure to touch it up.

Your authority to do this is MWO Ord 763-W3 (3 May 57).

Clean as a whistle

Here's a good tip on keeping your vehicle's cooling system free of rust. Lay off using that engine cooling system cleaning compound (MIL-C-10597B), FSN 6850-272-9327, when you drain that system in the Spring and Fall.

More harm than good can be done to the system if that compound's used too much. After cleaning with this stuff, the metal surfaces are primed for rusting.

So, never use the compound as a routine thing—use it only when it's needed to clean out badly clogged radiators or rusted cooling systems.

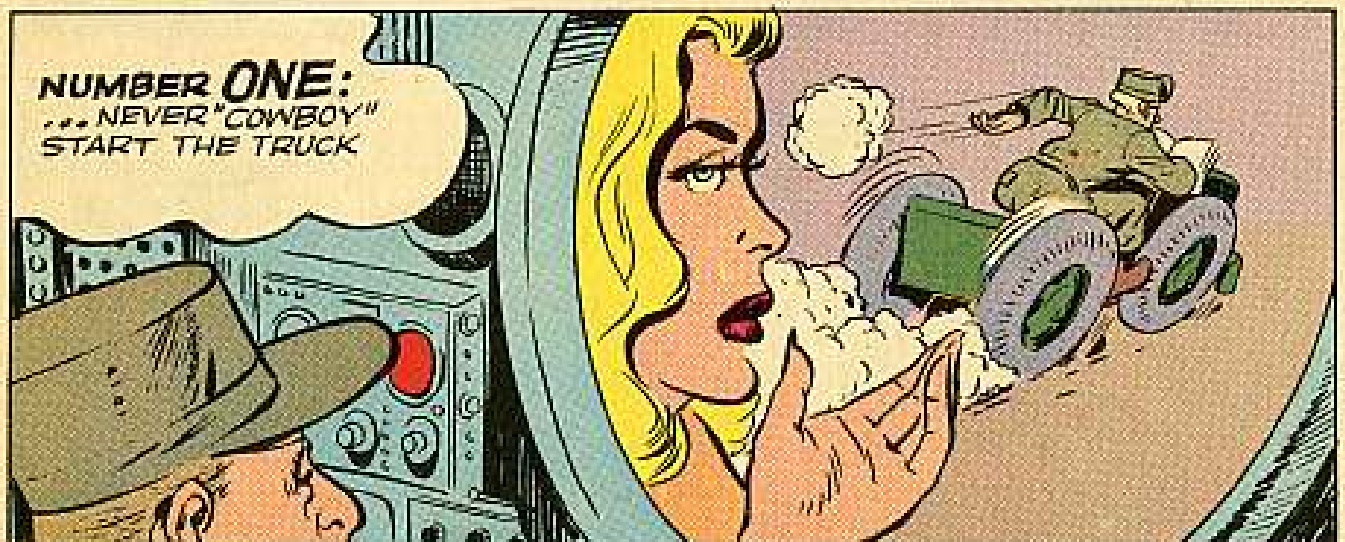
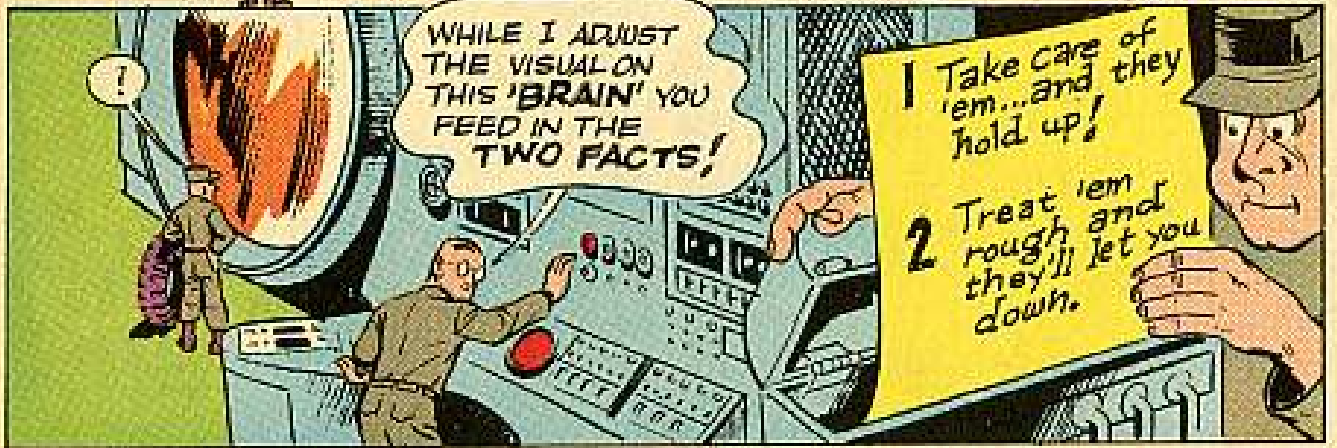
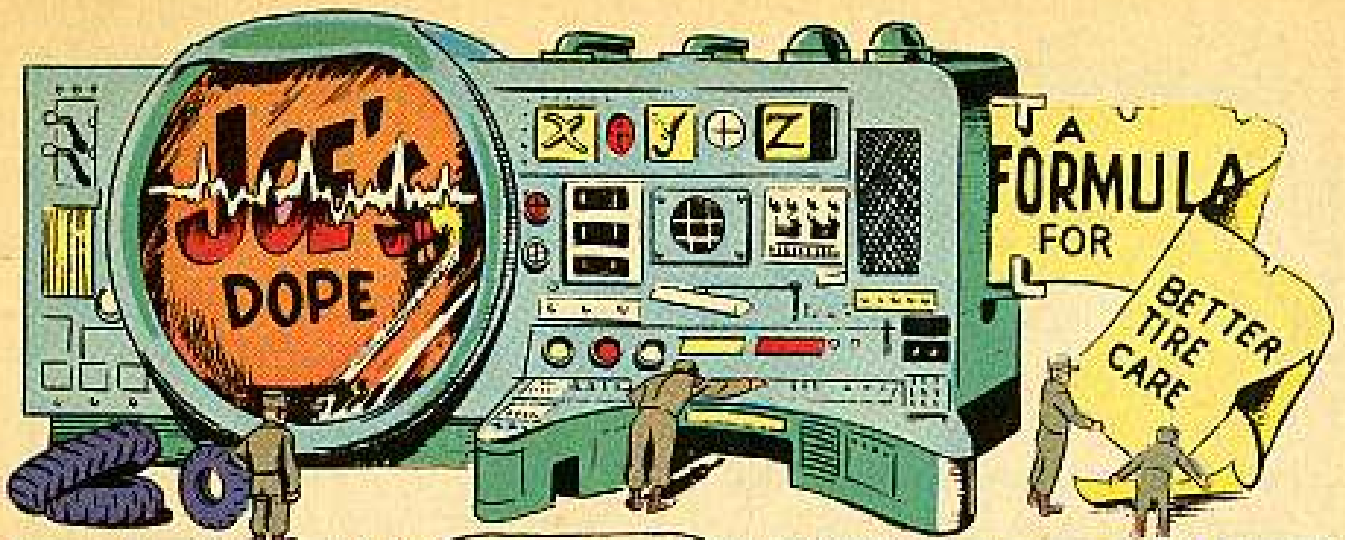

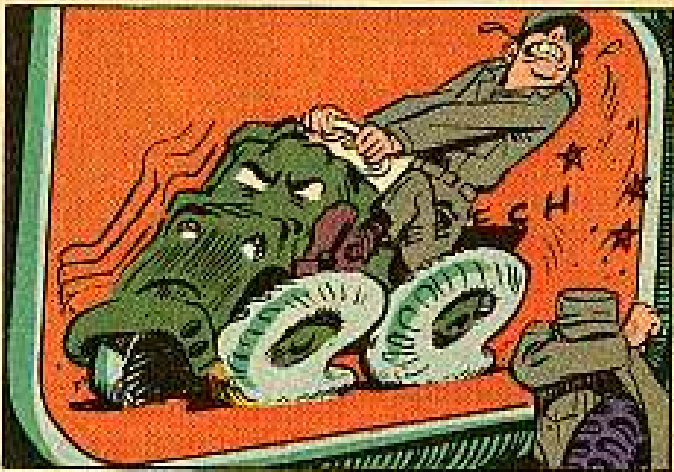
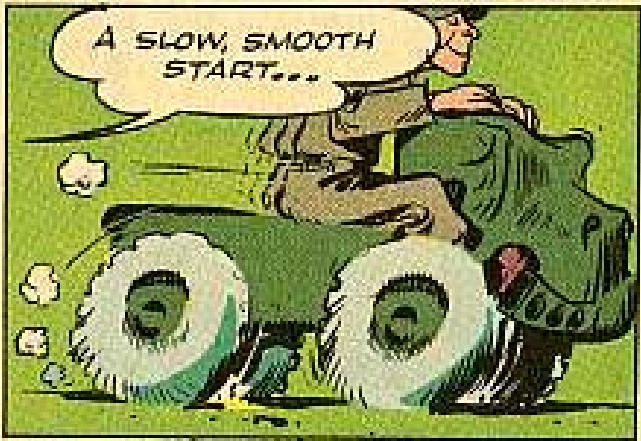
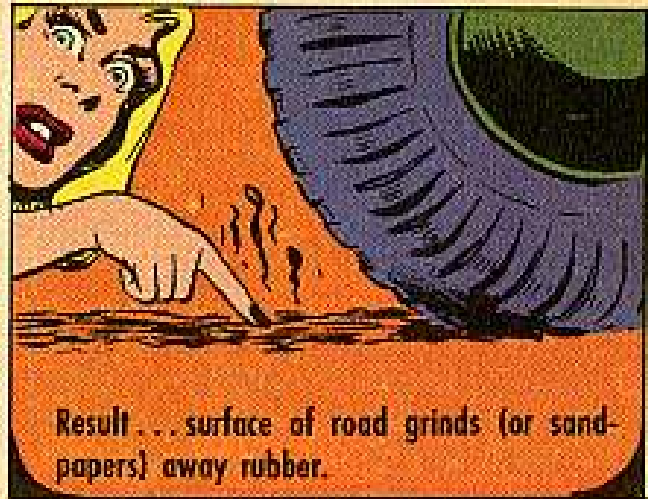

**NUMBER THREE: A BIG
TIRE KILLER IS SPEED
... PASTE THESE THOUGHTS
IN YOUR HAT!**

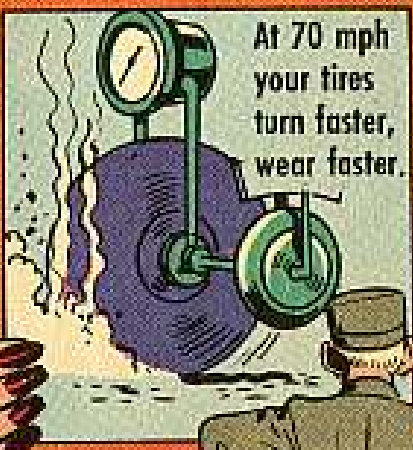

At 70 mph
your tires
turn faster,
wear faster.

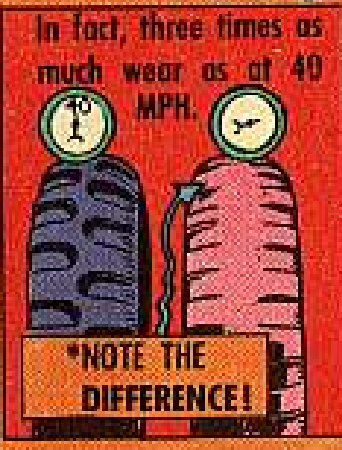

In fact, three times as
much wear as at 40
MPH.

***NOTE THE
DIFFERENCE!**

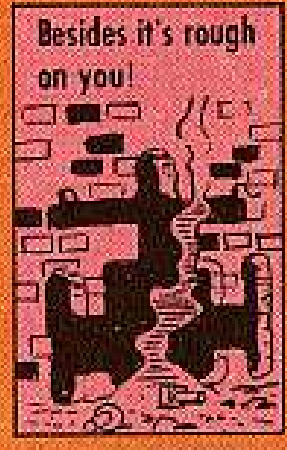

Besides it's rough
on you!

**NUMBER FOUR
... TIRES HAVE GOT TO
BE INFLATED RIGHT
ALL THE TIME FOR
THE PROPER WEAR...
HERE'S THE DOPE!**



Check your tire pressure
only when a tire is
cold... because...

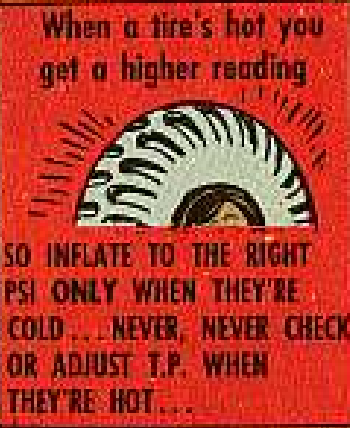

When a tire's hot you
get a higher reading

**SO INFLATE TO THE RIGHT
PSI ONLY WHEN THEY'RE
COLD... NEVER, NEVER CHECK
OR ADJUST T.P. WHEN
THEY'RE HOT...**



... and check your
TM for their proper
pressure

Joe's

Dope Sheet

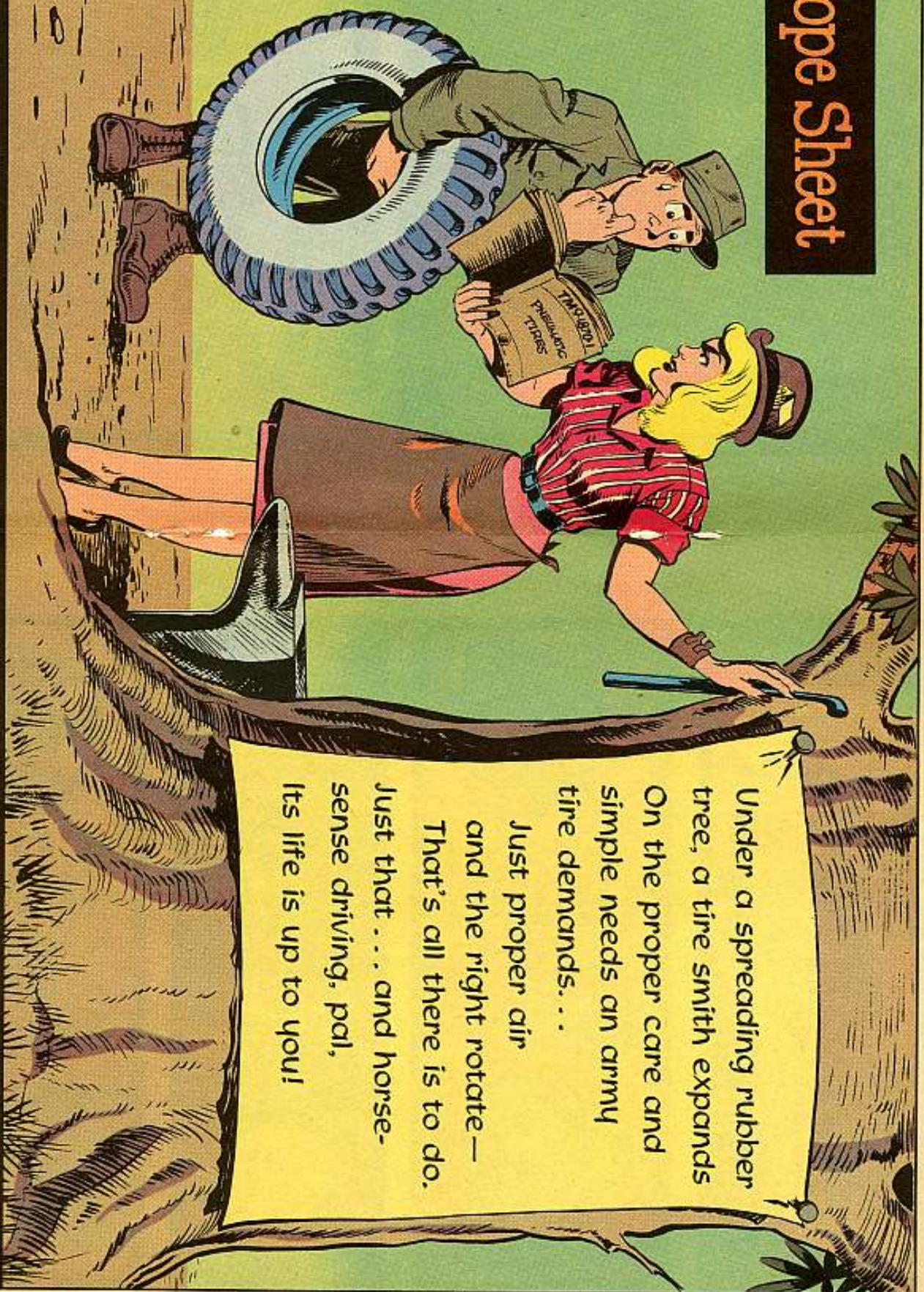

Under a spreading rubber tree, a tire smith expands On the proper care and simple needs an army tire demands. . .

Just proper air and the right rotate— That's all there is to do. Just that . . . and horse-sense driving, pal, Its life is up to you!

WE HAVE THE WORLD'S BEST EQUIPMENT . . . Take care of it

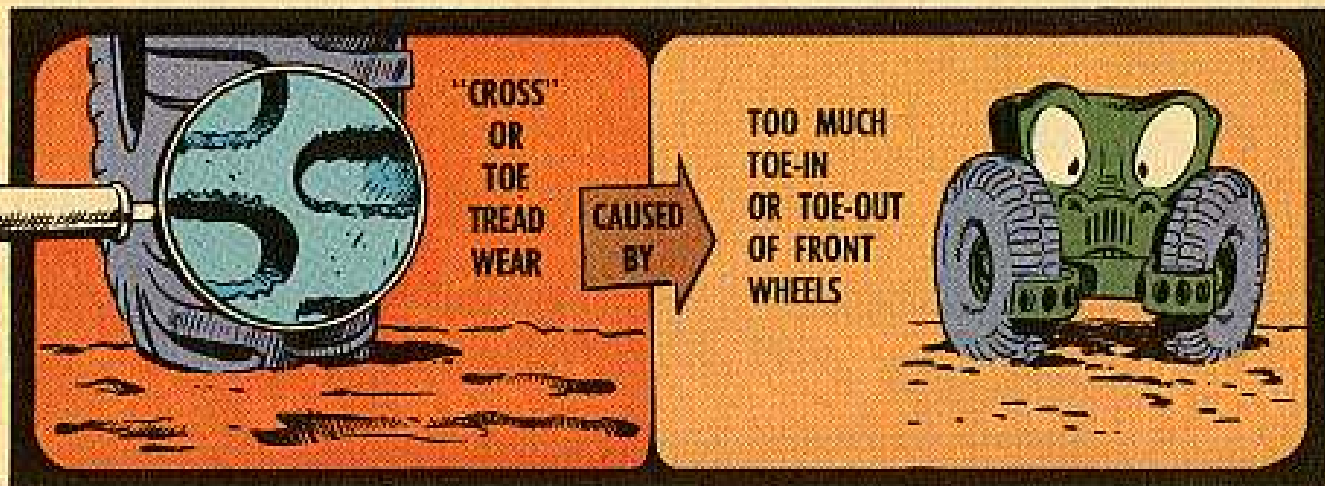
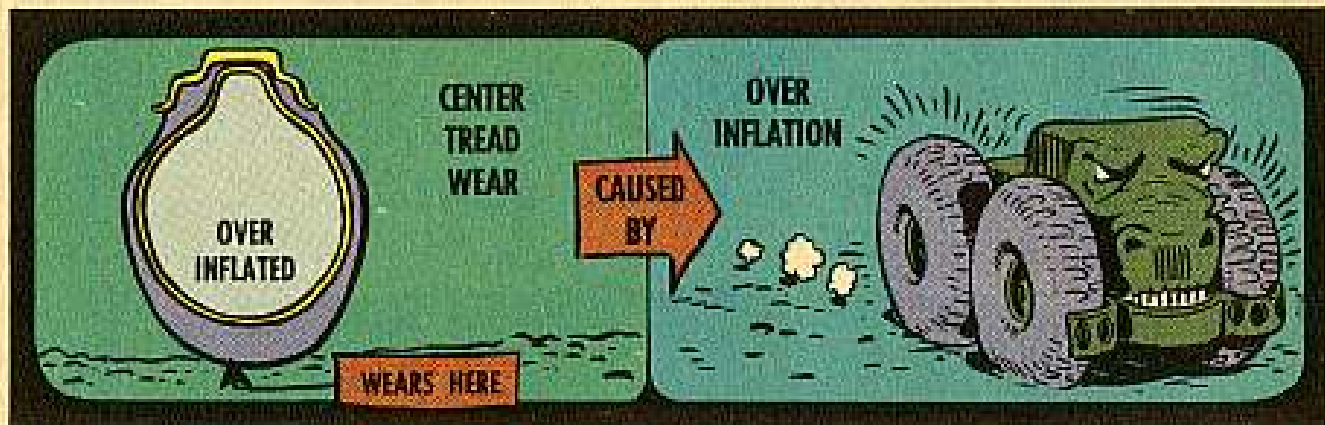
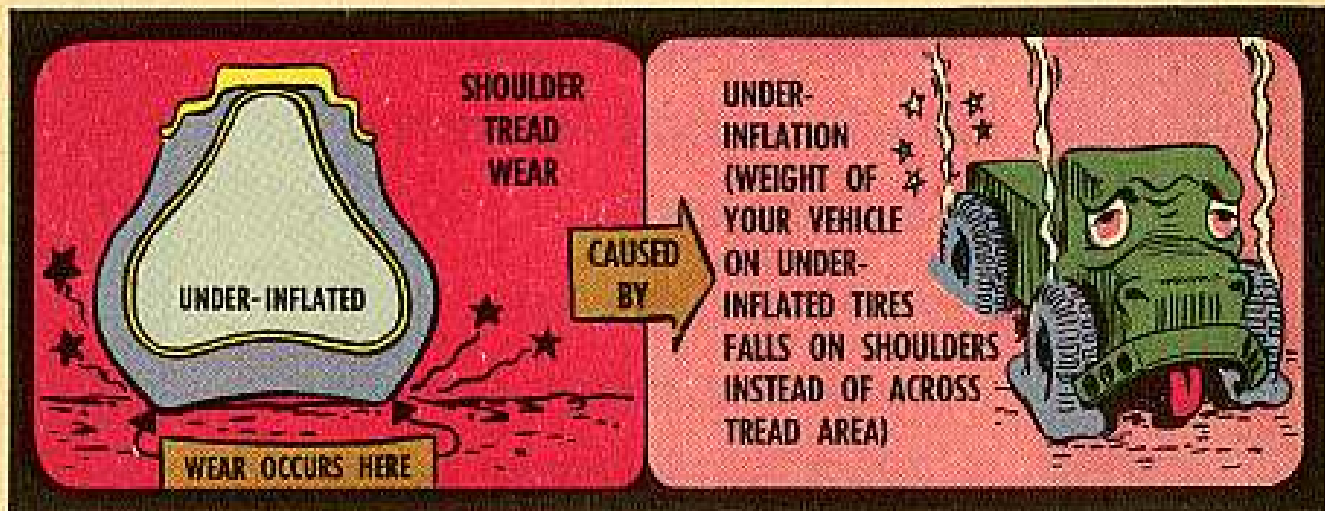

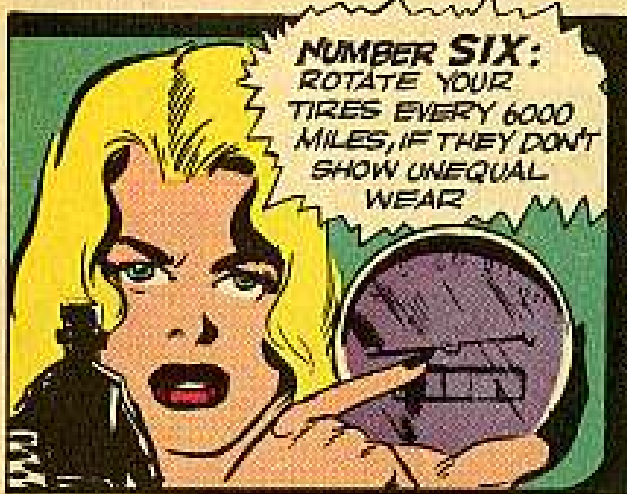
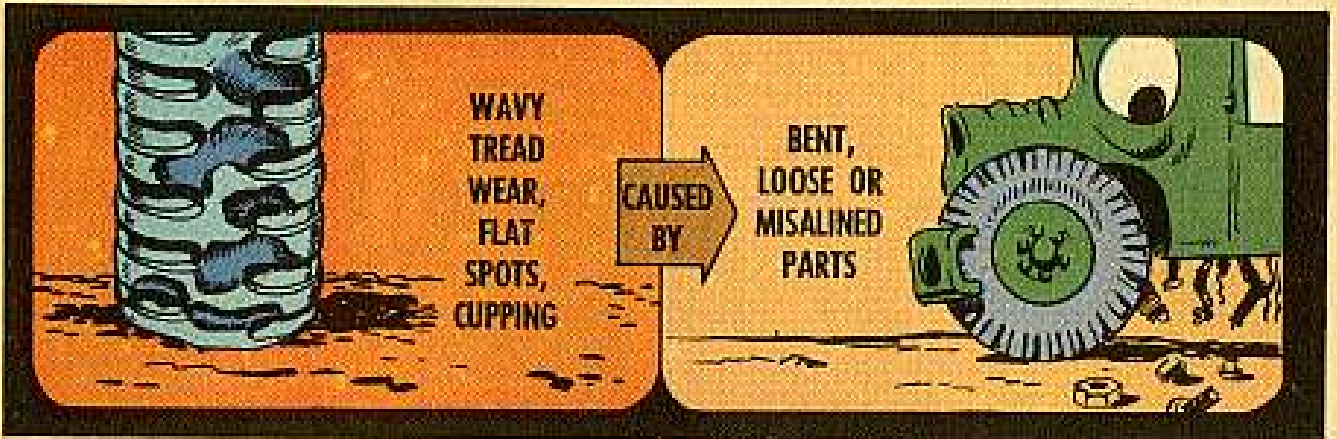
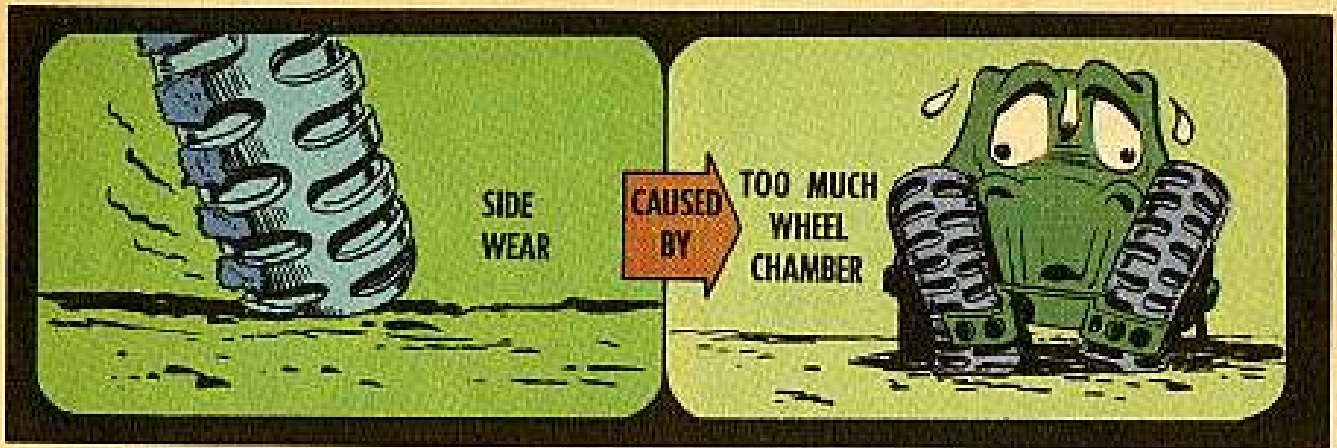

BUT... if they show unequal wear, find out why, fix it, then rotate every 2000 miles until uneven wear straightens out.

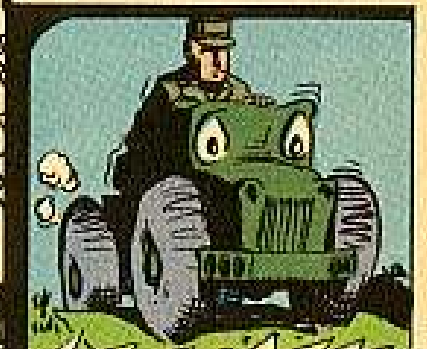

Rotating tires (including spare) gives you lots more wear out of them.

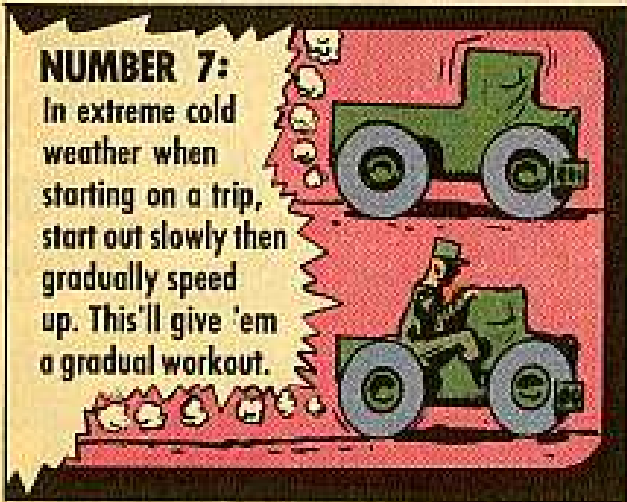

NUMBER 8: HEAT, usually caused by over-inflation or under-inflation is one of the worst tire killers.

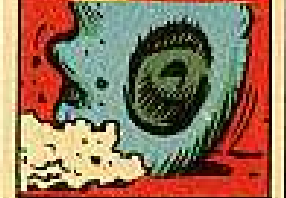

One thing more...TM-9-1870-1 is just the thing for pneumatic tires, especially section III. So take a look, huh?

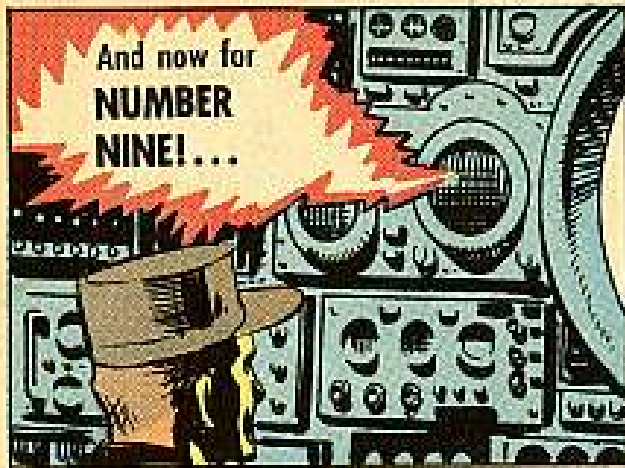

And now for
**NUMBER
NINE!**...

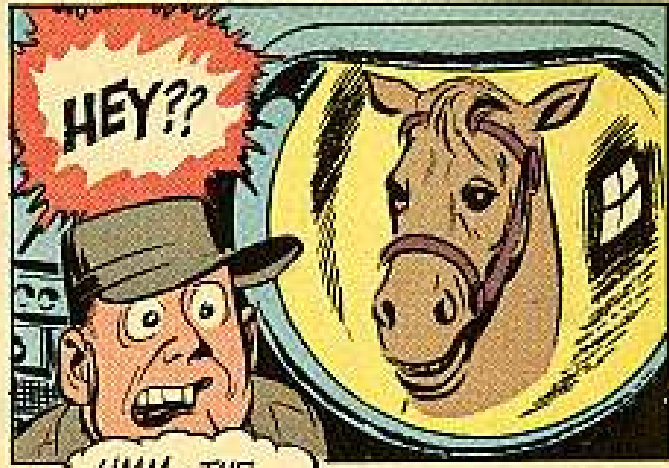

HEY??

HMM... THE
FILAMENT ON THE
CONDENSER TUBE
LOOKS BENT... OR
MAYBE ITS THE
CRANARFARF

I GOT NO TIME
FOR THIS JAZZ...
I'M GOIN' TO SEE
CONNIE PERSONALLY...



HEY... Y'GOT A HORSE
ON THE SCREEN
...SOMETHIN'S GONE
WRONG WITH THE
WORKS!

QUIET—
I'M TRYIN'
TO FIX IT



ON THE DOUBLE,
DAD... I GOTTA
GET THAT
NINTH POINT...



SNAP!



TWO HOURS LATER

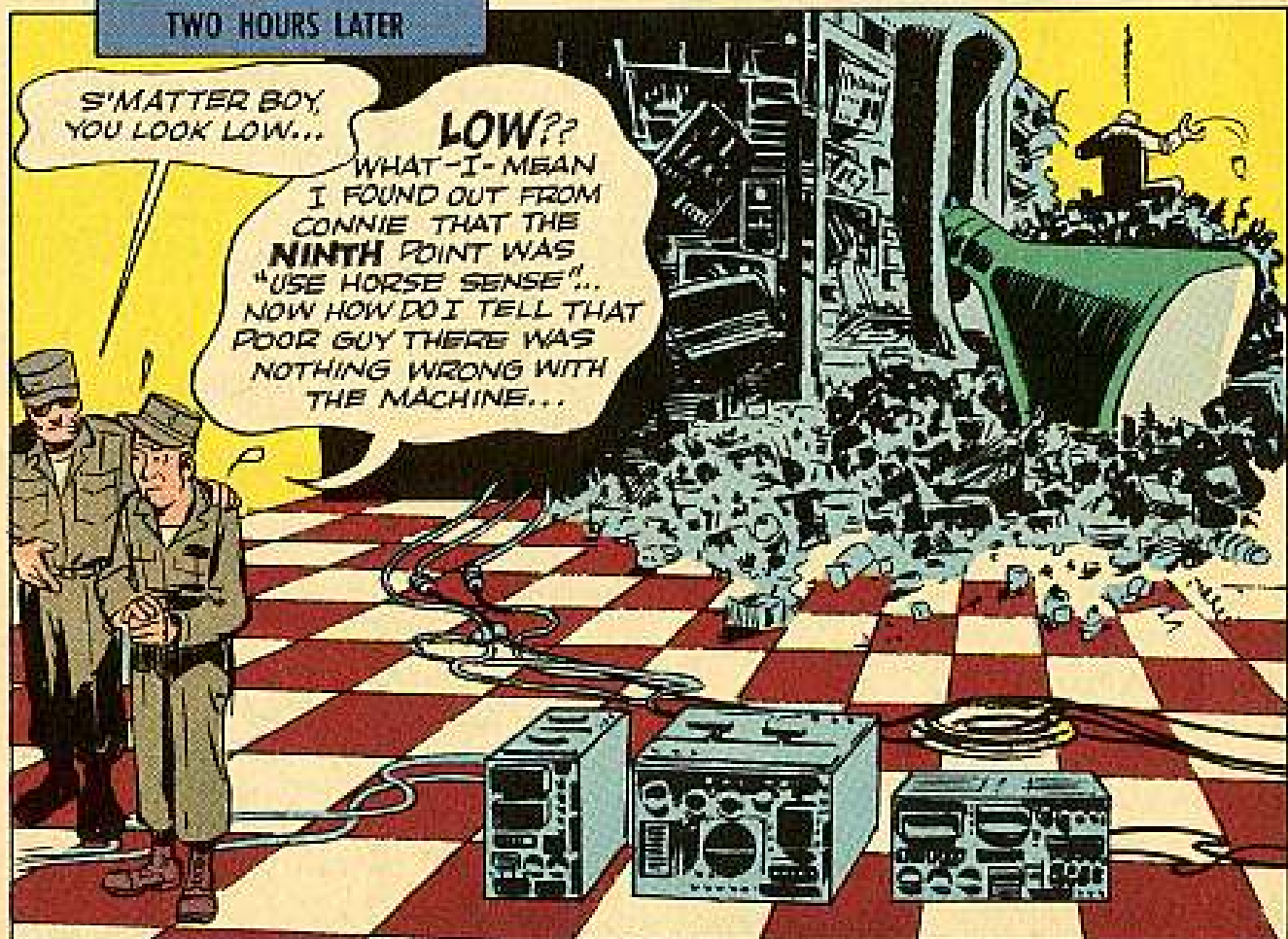

S'MATTER BOY,
YOU LOOK LOW...

LOW??
WHAT-I-MEAN
I FOUND OUT FROM
CONNIE THAT THE
NINTH POINT WAS
"USE HORSE SENSE"...
NOW HOW DO I TELL THAT
POOR GUY THERE WAS
NOTHING WRONG WITH
THE MACHINE...

QUESTION AND ANSWER DEPARTMENT

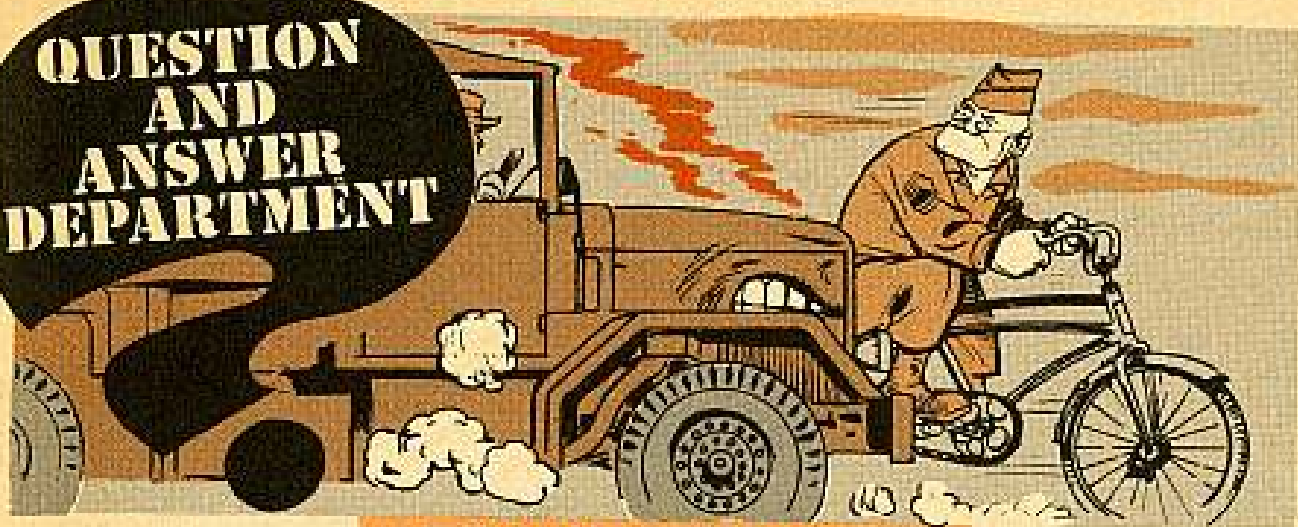

FOULED PLUGS

Dear Half-Mast,

This Korean speed limit of 25-MPH has given me lots of grief. All my engines are carboning up and fouling plugs like crazy.

I've helped the situation a good deal by telling all the drivers to do a good bit of running one gear down from the top. According to the dash plates, all my wheeled vehicles allow me to operate at 25-MPH in fourth speed (on the 5-speed jobs) or second speed (on the 3-speed models). This sure keeps the plugs cleaner.

Got any better idea?

SFC J. H. C.

Dear SFC J. H. C.,

All your wheeled vehicles will hit 25-MPH in the next-to-highest gear without exceeding the permissible speeds as shown on the dash plates (which means they'll do it with the engine turning well inside its maximum permissible RPM's).

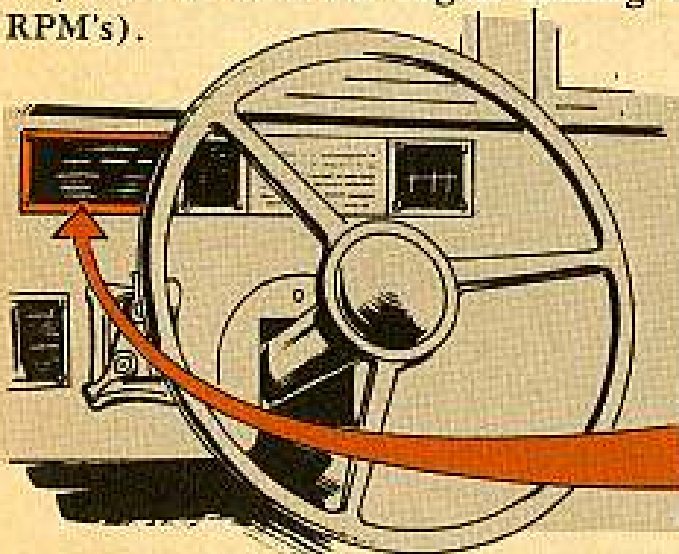

CAUTION

MAXIMUM ROAD SPEED IN M.P.H.

TRANSMISSION	TRANSFER CASE	
	HIGH	LOW
FIFTH (DIRECT)	60	30
FOURTH	42	21
THIRD	25	12
SECOND	14	7
FIRST	8	4
REVERSE	8	4

Used occasionally, this'll undoubtedly tend to clear your plugs and burn out some of the oil fouling, and at the same time it'll prevent any lugging of your engines. Your larger trucks should not be in top gear with a load on 'em until

they're rolling lots faster than 25. They go into the 40's in fourth, and top is just for highway highballing.

But, doing this all the time is a little expensive in gasoline and engine wear.

Engines doing a lot of slow speed running should have the hotter of the two authorized spark plugs. These plugs are designed so that the insulator and



center electrode reach a higher temperature than the cold type plugs. This tends to prevent oil fouling. You'll find 'em listed in your Number 7 supply manuals under FSN 5935-835-7724.

Get ahold of TM 9-8638 and read paragraph 14. It gives you the full info on how hot and cold plugs are used.

Remember—you've got to change the whole set. You don't want your buggy stooging around with three hot and three cold plugs or some such mixture as that.

Also, of course, you must be sure that your plug fouling is not being caused by a ruptured fuel-pump vacuum diaphragm on the ¼- and ¾-ton trucks, or by closed crankcase ventilating valves or clogged ventilating lines on any size truck. And a carburetor that's not adjusted to your climatic conditions will also cause fouled plugs. If you suspect this . . . call on your support unit for help.

SPACER SET

Half-Mast



Dear Half-Mast,

When working on the front axle steering knuckles of the G742-series 2½-ton trucks, we've found that many times we need a spacer. Can you tell us if there are any available in supply?

MSgt T. C. C.

Dear MSgt T. C. C.,

There is a spacer set in supply for use on that G742-series 2½-ton truck. It goes under FSN 2530-752-1679-(G742) and has seven spacers in it from 0.185 to 0.245 thickness.

Of course, you know that any work you second echelon people do on the steering knuckles of those trucks has to be done with the blessing of your support unit.

Half-Mast

SHAFTED

Dear Half-Mast,

We've been getting a boot in the pants from our inspectors when they inspect the propeller shafts of our M-series tactical wheeled vehicles. They say they're too loose. Is there such a thing as a too loose shaft?

SP-2 P. L. H.

Dear SP-2 P. L. H.,

Sure is—but people have to use their heads about what's too loose and what isn't.

The secret to the whole thing is to make sure you hold the slip yoke tight and stationary when checking out looseness. All prop shafts develop backlash between the splines of the shaft and the slip yoke. Backlash increases as the splines wear. If you get too much backlash and notice that the splines are worn pretty much, then it's time to change the shaft.

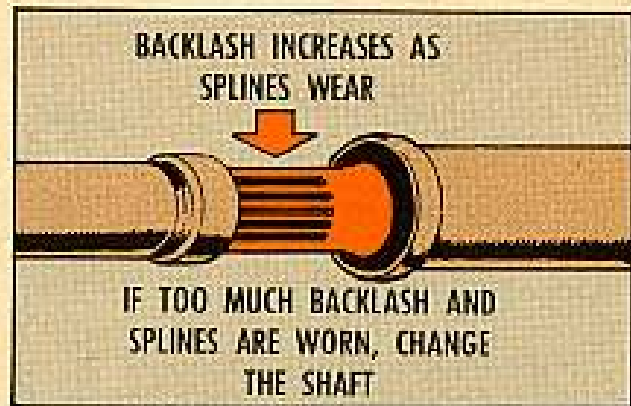

HOLD SLIP YOKE STILL... ... WHILE TWISTING SHAFT

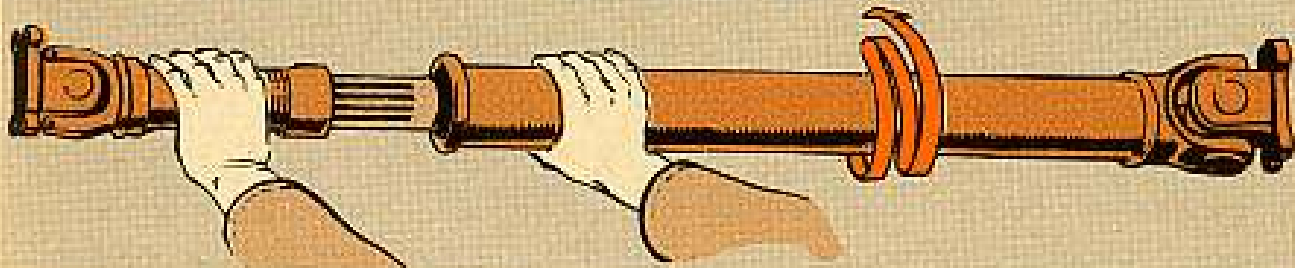

If your inspectors aren't holding that slip yoke stationary when checking the shaft, they can get a false impression. They'll get play from the power train or from a worn universal joint. That'll give the impression of too loose a shaft.

For replacement and further checks of prop shafts, see your vehicle's TM.

Half-Mast

TRACTOR-TRAILER TREMORS

Dear Half-Mast,

Got a couple of new 6-ton, 2-wheel, M119 semitrailers like our TOE calls for, but no truck tractors to pull 'em. So, they stand there, not doing anything but gathering dust and rust.

We do have M52 5-ton tractors (again, according to our TOE), but we know that you can't pull the M119's (or the M118's, for that matter) with this tractor. We know you need either the M48 or M275 2½-ton truck tractors (G742 series).

Is there any way we can exchange our M52's for the others, so we can get our trailers out of the pea patch?



Dear SP-2 W. L. B.,

Here's the deal:

First, submit a requisition through channels for a supply of those 2½-ton tractors (order the quantity your TOE calls for). In your justification state that you need these tractors so you can pull your M119 trailers—in other words, that you have the M119's, and the M48's and M275's are the only tractors made that'll fit 'em.

Now, those M52's aren't doing you any good unless you have 12-ton trailers. So, why not turn them in and give some guys who need them a crack at getting them. All your CO has to do is declare the M52's excess and turn 'em back in. He should use Standard Form 120, "Report of Excess Personal Property," when making this turn in.

Finally, your CO should report the whole situation, through channels, to CG USCONARC, Fort Monroe, Virginia, ATTN: ATING, and recommend changes to the TOE under which you're now operating.

Half-Mast

LUBE LEVEL PLUG

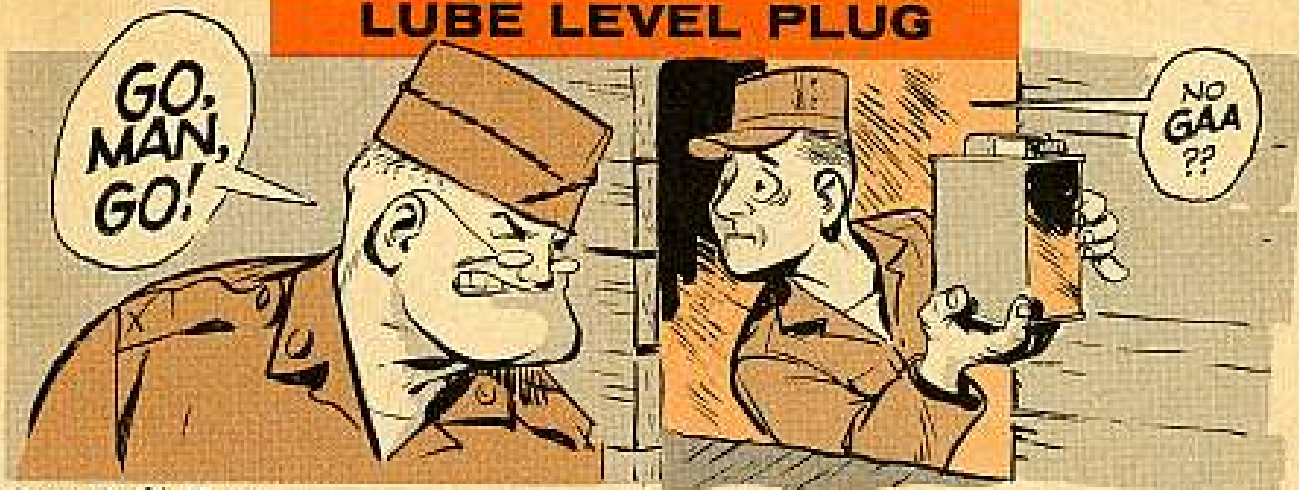

Dear Half-Mast,

What's with the winch gear boxes on the M123 10-ton truck-tractor? LO 9-8002 (Dec 55) says to fill 'em with GAA. Is that right? For a gear case?

And then I can't find any level plug on the cases. How do I know when to stop filling 'em?

SFC D. K. H.

Dear SFC D. K. H.,

You're right, but you've got the wrong info. LO 9-8002 (6 Aug 57) supercedes the old one and tells you to use GO in the winch gear-boxes.

You'll fill 'em through the $\frac{3}{8}$ -in pipes that come out the holes in the mounting frame, and you'll find your lube level plugs on the side of the gear-boxes (toward the outside of the truck).

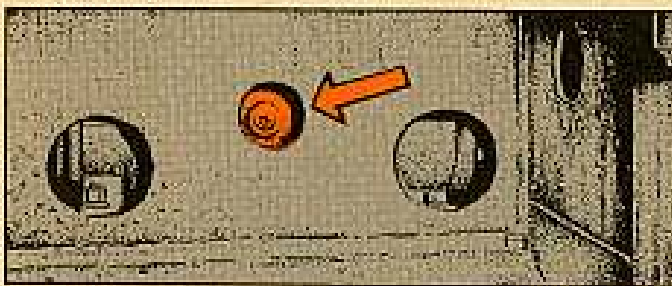
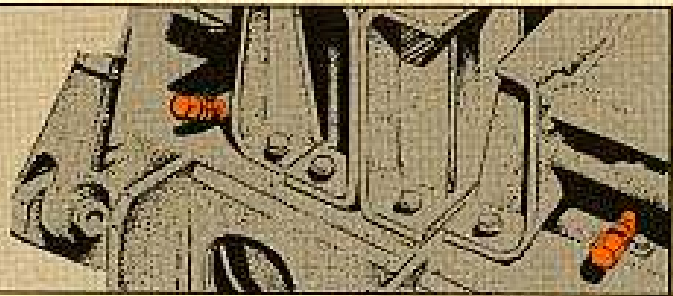

You'll want a hex-head (Allen) wrench to get the plugs out. The one on the right-hand winch can be reached through a special hole through the mounting.

The left-hand plug is in sorta close quarters, but you can slip your hand down to the right of the cable fairlead sheave and you'll find you have room enough to work.

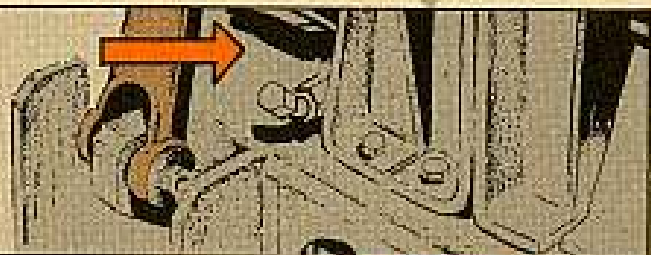

Half-Mast

COOL, MAN? WARM'ER UP



Dear Sgt Dozer,
I'm having a tough time convincing my buddy that all liquid-cooled engines should have thermostats in the summer. He says that in the summer you have trouble with engines overheating, not overcooling, so they'll work better with the thermostats out.

Sgt H. D.

Dear Sgt H. D.,
 Lots of people—like greenhorn drivers—take a long time to learn that thermostats are important in the summer. The point to the whole thing is this: Get engine coolant up to its operating temperature quick as you can, and keep it there. That goes for any place any time of year.

Naturally, even greenhorn drivers keep this in mind during the winter. After all, the heater won't work until the coolant's heated up. But it's also important to let an engine heat up before operating it in the summer, too—'specially on cool mornings.

What happens when your engine's working hard and its coolant's cold? Little drops of water form inside the cylinders and run down into the crankcase. A little condensation doesn't hurt much, but after awhile it starts to form sludge. That black, heavy sludge clogs the engine, makes it work harder, and wears it out faster. Another thing: Gasoline condenses on the cylinder walls and washes the oil off. Naturally, that makes for wear.



If you run into the problem of overheating, taking out the thermostats is not the answer. Hang them in a container of cold water. Don't let 'em touch the bottom or sides of the container. Heat the water and check the thermostat opening temperature by testing with a thermometer. If the thermostat opens more than 10 degrees below—or 15 degrees above—where it's supposed to,

On thermostats that are supposed to open at 180° F:

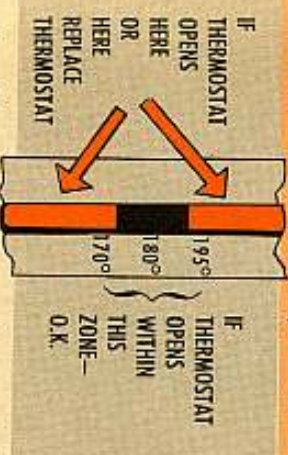

forced from the pump to the top of the radiator. You can lose enough coolant that way to cause your engine to overheat.

Sure, operation below operating-temperature is more likely to happen in the winter. But it also happens in the summer.

So make sure your engines have thermostats . . . if they're supposed to have 'em, on moving or stationary equipment . . . and let engine coolant warm up to operating temperature before putting a load on the engine.

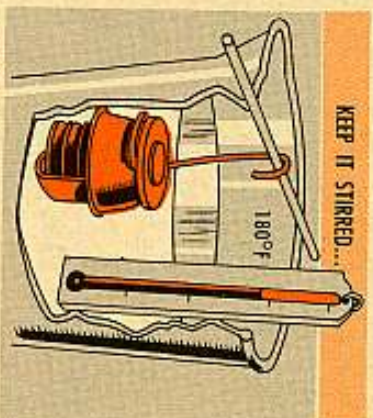

to, get a new one.

If you get overheating when the thermostats are good, the cooling system needs a good flushing. The thing to keep in mind is: Thermostats do not cause overheating.

Thermostats do another important job besides keeping your engine at operating temperature. On some types of engines, the thermostat acts as a baffle against the volume of water being forced from the pump to the top of the radiator. Without the baffle, water can

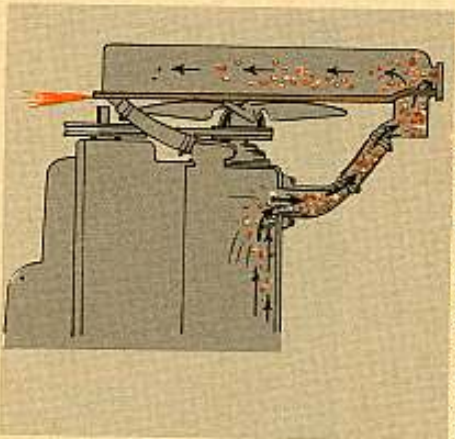

MISSILE BLASTS

Never forget 'em and they'll be ready...

WHEN



Take the sump pump, air heater and exhaust fan at your Nike site. They don't seem like much when you compare them with your more important or more expensive stuff. In that kind of company it's easy to overlook the fan-heater-pump combo when you're pulling PM.

SUMP PUMP

Take the sump pump, for instance. Like its name says—it has to take care of all the water that gets in the sump in the pit. The sump's in front of the main cylinder and lower than the pit floor... and, that's well below the water level in most cases. The pump can be overlooked real easy because it's hidden by the elevator whenever the elevator's on the pedestals.

Lubing the pump and the motor is the most important part of maintaining it. On some pumps, the motor bearings and the ball-thrust bearings may be sealed. There's no sweat at all then, since all you have to worry about is lubing the lower sleeve bearing at the pump.

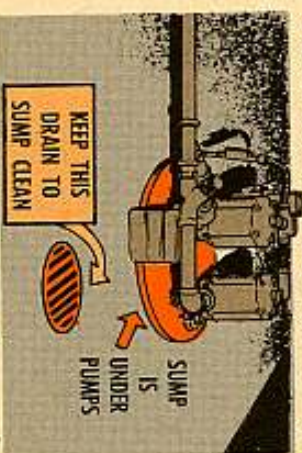
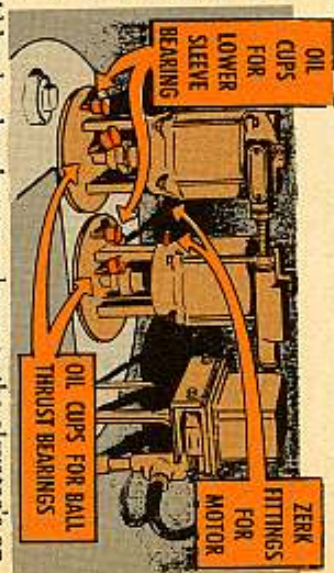

and the housing, the impeller may freeze up and you've got a real bailing and clean-up job on your hands.

Keeping the suction screen and drain clean and free of debris is another part of your regular PM. If leaves, sand, and other stuff clog up the screen or the drain, your pump won't give out with anything near a 100 per cent job. Then, too, if any of this gunk gets past the screen and collects between the impeller

YOU NEED 'EM

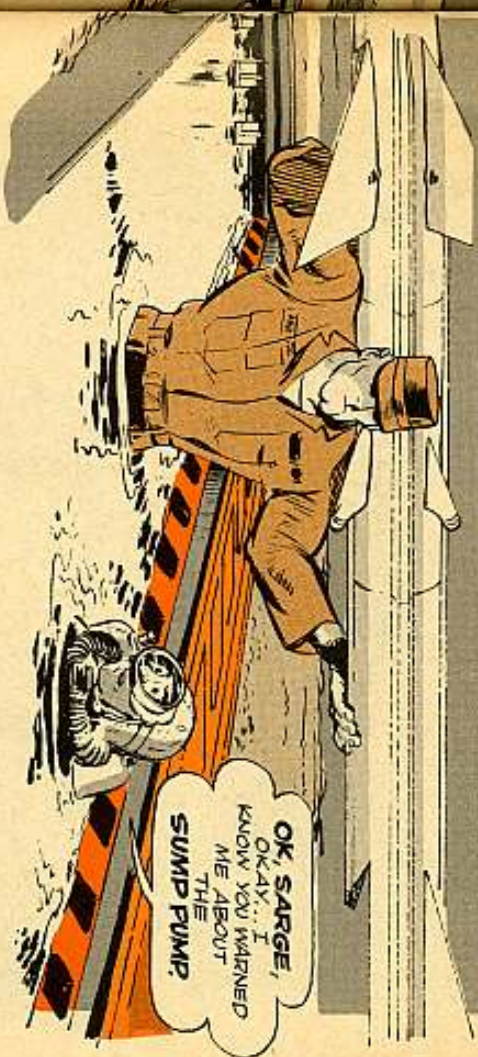

AIR HEATER

This heat producer is designed to keep the mercury in the pit above the 50° mark. Of course, a lot depends upon the number of times a day the doors are open—and how long you keep them open. These little de-icers are local-purchase items which means you may have any one of a half-dozen types in your pits. Regardless of the type that you

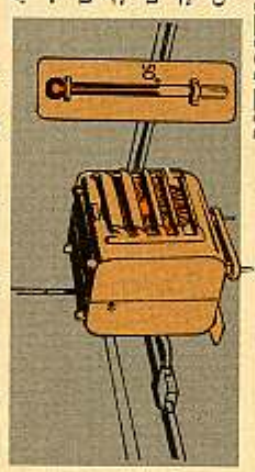

have, don't overlook them.

Turn off the juice to the heaters as you work on 'em. The big thing is to remove the dust from the grids. (You use a stiff brush, a cloth, or even a broom for the job.)

A heavy layer of dust on a heating element is a fire hazard. When you get rid of the dust, you get rid of the hazard at the same time.



Since the fan motor is sealed and needs no lubrication, about the only other maintenance you have to pull on the heater is resetting the thermal overload switch. The switch will automatically break the circuit in case the motor fails or if the air flow through the heating element is blocked. Once the switch clicks open, it has to be reset by hand. Now, for the exhaust fan...

EXHAUST FAN

SERGEANT DOZER,
WE ARE WORKING UNDER
ADVERSE CONDITIONS AS A
RESULT OF THE MALFUNCTION-
ING OF THE EQUIPMENT DISCUSSED
HEREIN!



Like the heater, the exhaust fan needs little maintenance and is also a local-purchase item. So again you'll run into a raft of different manufacturers. The fan's job is to be ready in an emergency to change the air in the pit every four minutes. If acid is spilled and the fan goes on the blink—you can bet your breathing down below won't be fun.

The motor and fan bearings and the V-belt are the only items you have to check out come maintenance time. Most of the fans have sealed-for-life bearings, but if yours is the type that requires lube—see that it gets lubed. Even though it's a light-duty fan, don't use a light-duty oil like the common household or sewing machine oil. Use at least 10-weight oil.

One thing more—keep the fan wheel clean. Clots of dust and dirt can build up on the rotor and throw the wheel out of balance.

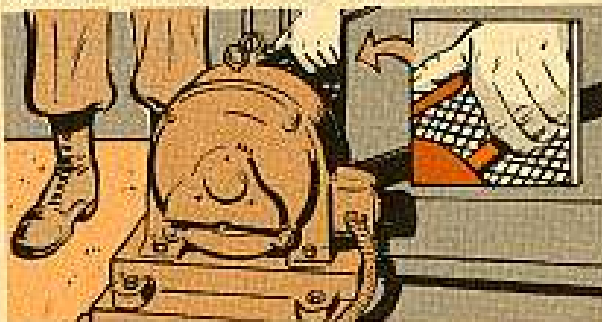
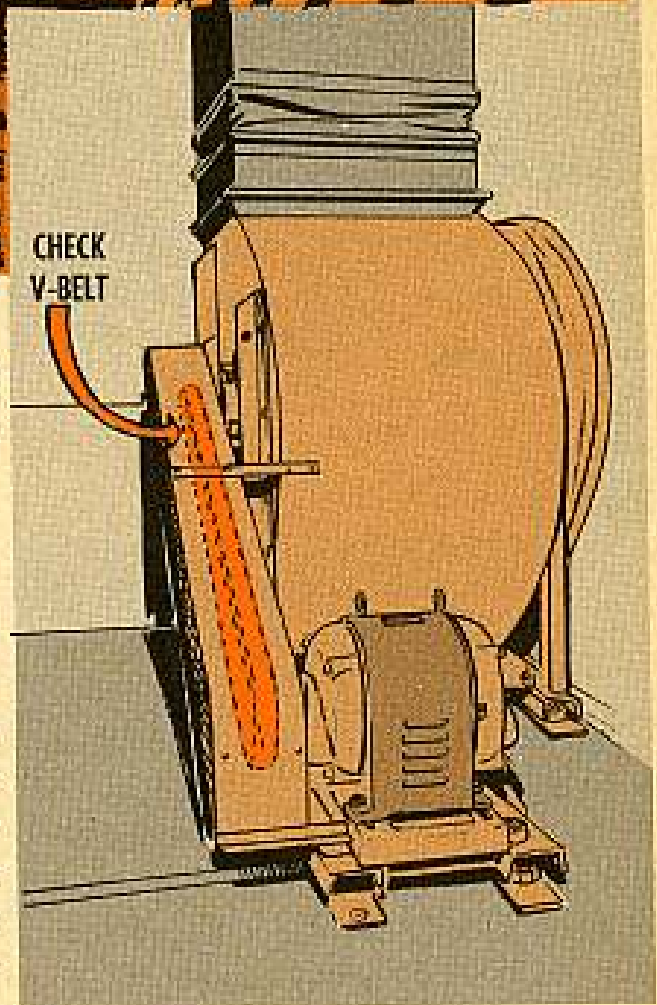

When installing V-belts, allow enough slack so they can easily be put in the grooves and you don't have to force them on the sheaves. Keep the belt at the proper tension—not too tight so it puts a strain on the bearings, but not so loose that it causes slippage.

PINCHED PINS

Got a minute? Then take a squint at the J2 plug that goes into the J2 receptacle on the guidance section of your Nike-Ajax missile.

If you see any of those hollow contacts in the plug not fully open like they should be, now's the time to straighten 'em out—before you try hooking up the plug to the receptacle.

Let 'em go and forget 'em... and first thing you know you'll be jamming the sides of the contacts and collapse 'em shut—and push the contact into the plug's rubber backing. Could also break the hollow contacts and bust the insert pins in the receptacle.

To keep those contacts straight and open, all you have to do is carefully stick a small, smooth-ended point into the contact that's bent and slow and easy-like bend the sides back into the full open position. You can make the tool out of something like a coat hanger by cutting off a four or five-inch piece and then grinding one end to between $\frac{1}{32}$ inch and $\frac{1}{16}$ inch in diameter for a distance of about $\frac{1}{2}$ inch. You might put a bend in it.

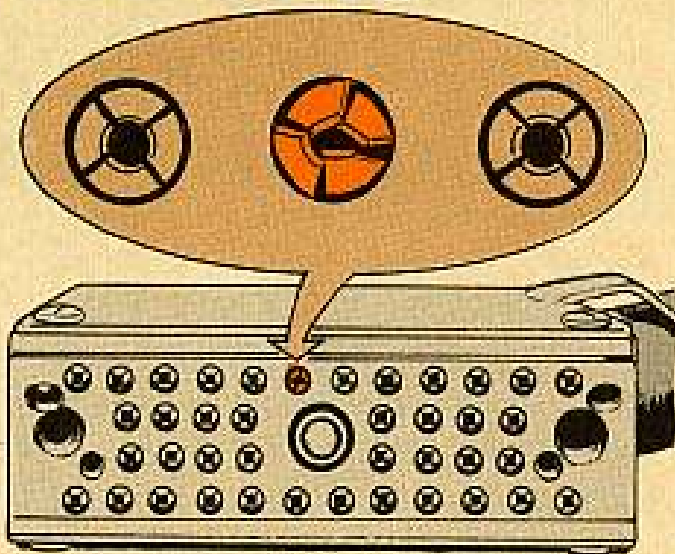
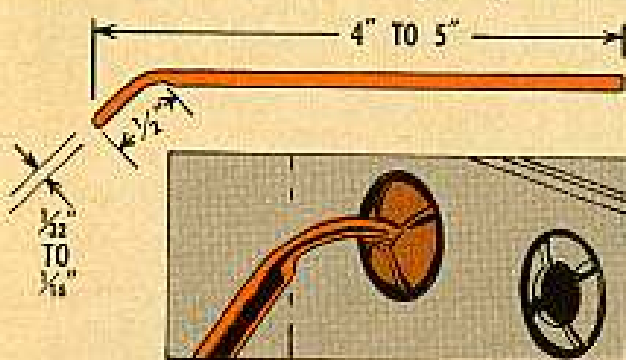

Check your plug each time before you hook it up... and be sure to be real careful when mating it with the receptacle.

TIGHT, ALL RIGHT?

How's by the J-1 plug on your Nike-Ajax missile? Some missiles have a loose plug when they reach a site. The loose plugs are showing up mainly on 9,000 and 10,000-series missiles, but it'll pay you to check the plug on the other series missiles.

All it takes—as you know—is a few twists on the screwdriver to tighten the screw that holds the plug.

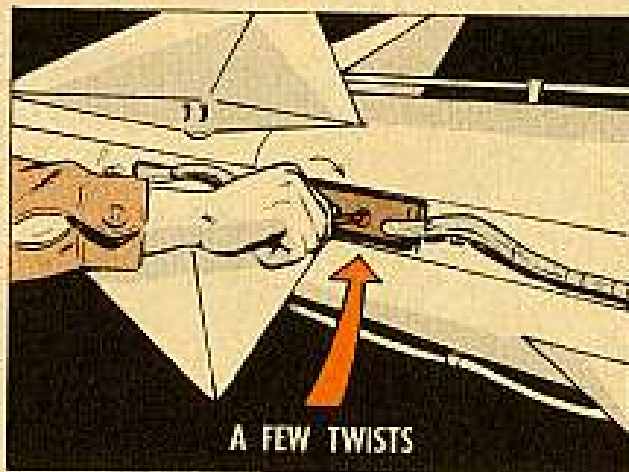

KEEP 'EM CLEAN AND DRY



Ground power plug assemblies on Nike-Ajax missiles can be pesky as a cat in a canary factory. Water and oil collect around the plug contacts and short them. In some cases, plugs have shorted so bad that gyro units in test stations attached to the missile have operated without being turned on.

Those ground power plug assemblies have to be in A-1 shape all the time so they'll work right comes a big flap. These two jobs done the right way at the right time do the trick:

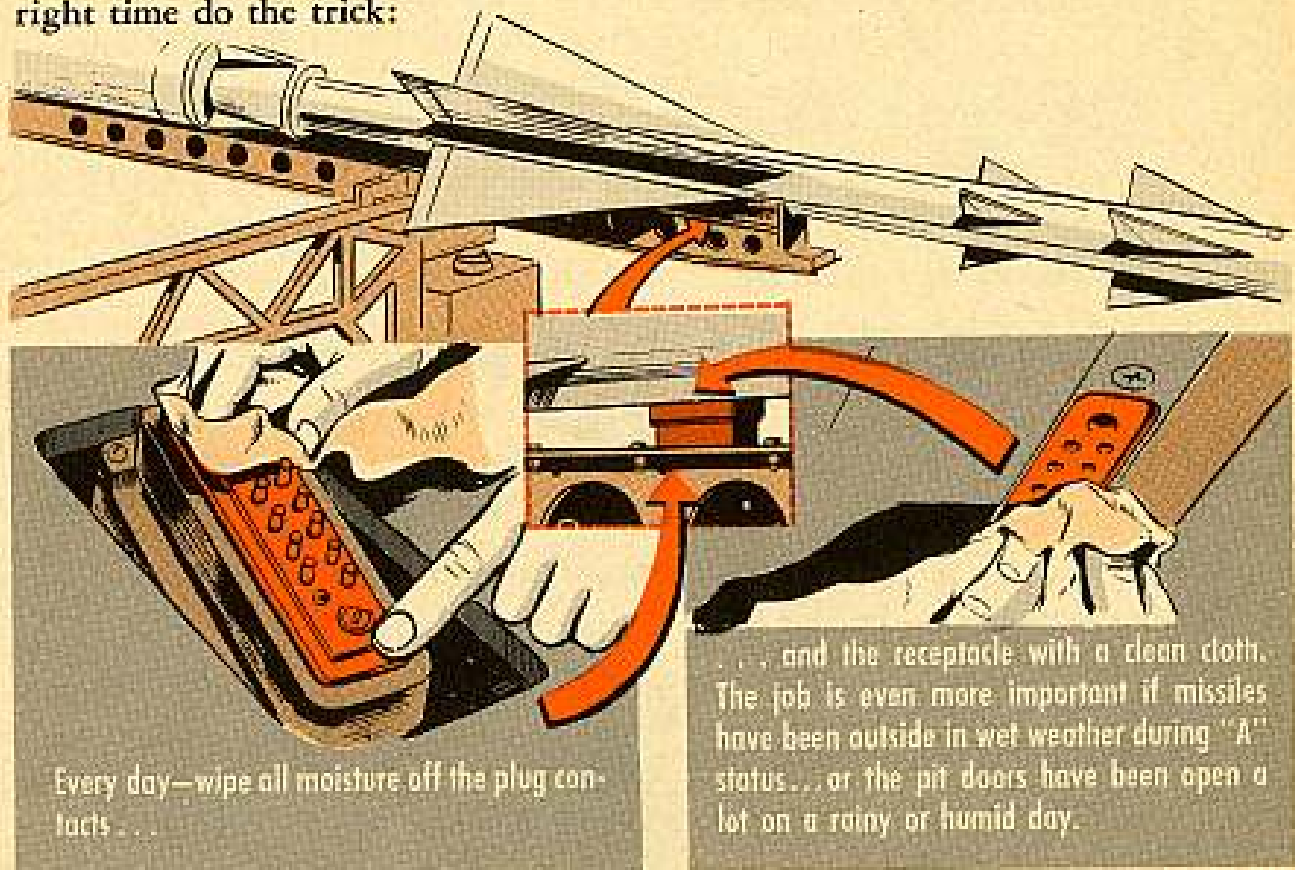

Keep the ground power plug body full of electrical insulating compound, but don't overfill. Don't let the stuff get on the plug's male contacts or the female contacts in the receptacle. The compound's an insulator—and the contacts are conductors. They don't mix.

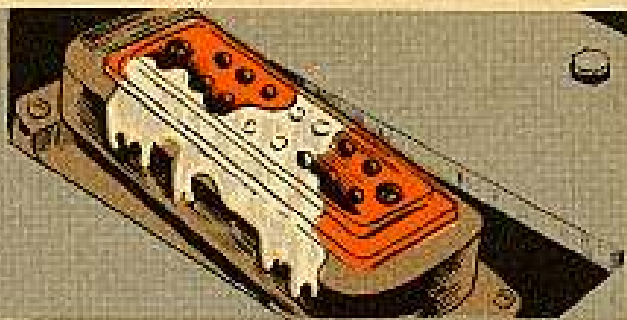

Water gets into the receptacle and around the contacts by condensation and from tunnel No. 3. There's no sure way of keeping water out of tunnel No. 3. It gets there by condensation. And water can run into the tunnel in bad weather if the tunnel's been taken off and put back on a good many times.

Oil running down tunnel No. 3 and into the receptacle means you have bad O-rings or a damaged or scored hydraulic bayonet fitting. Check 'em out and replace bad parts.

Why is it so important to wipe plug contacts and the receptacle clean and dry every day? Let's say the job isn't done for a few days in wet weather. Here's what happens: Water gets in the receptacle and runs down around the contacts.



There's no place for the water to go. It can't run down through the insulating block in the spaces around the contacts because the plug body is filled with electrical insulating compound up to the insulating block. So the water (and oil with it, if you've got an oil leak) stays on top of the compound—around the contacts—and causes shorts.

Remember that the insulating compound in the body of the ground power plug assembly **DOES NOT** keep water away from the contacts and the receptacle. The compound can't, because it's below the contacts and the receptacle.

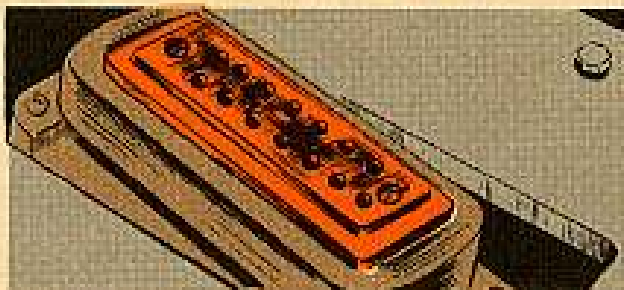

Wiping the contacts and receptacle clean and dry every day will stop shorts before they happen. You can tell when you've had a short by the burned places on the insulating block between the contacts.

Give it a little extra by wiping the plugs and receptacles after every "A" status in the rain. That little job could make a big difference at an important time.

A HOT REFRIGERATOR MEANS . . .

CONGESTION IN THE CONDENSER



Ever breathed through a schnoz that's 99% plugged, or sipped suds through a clogged straw? Enough to make a man give up and go dry.

Same principle goes to work when a refrigeration unit plods along with a clogged condenser. The motor groans and grunts and heads over the hill tryin' to suck air through a condenser that's packed tight with everything from dust to old issue slips.

Biggest headache comes from grease in the air. It collects on the fins and then grabs and holds dust particles like fly paper traps flies. And when the flow of air is slowed down, so is the process of changing gas to liquid (condensation). Once that starts happening the head pressure starts to climb . . . the motor starts to run hotter and hotter . . . and things'll build up to an engine burnout sure as reveille.

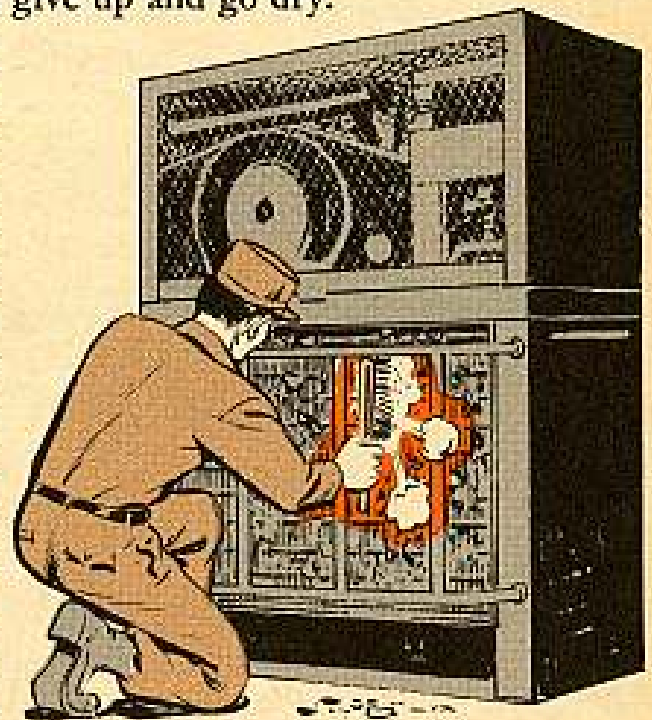

Yet the easiest kind of PM will head off that trouble every time—whether you're using a 1/3-ton Thermo Model on a portable 150 cu-ft box, or the big MQ-51 on a prefab warehouse. Or an ordinary domestic refrigerator.

A quick cleaning job can be done by your organizational mechanic. Be sure the unit is disconnected or the power is off. He'll use a brush, bellows, air gun, or even a cloth. Anything that'll get that dust and dirt from between the fins. The whole deal takes a few minutes at most yet sets a unit up for many a day of easy, cool running.

Once that condenser sheds its dusty coat, a few slaps with a rag when the dust starts to gather again will be plenty to keep it clean. Any time there's a question, of course, check your TM.

But be careful! Remember you can cut the bejabbers out of your hand on those fans.

PLUG THE PROBLEM



Dear Connie,

Pulling a neat crankcase drain job on a ½-ton Thermo King (K-10) refrigeration unit is like tryin' to save money on pass. The plug is snuggled back about three inches from the side of the control panel, flush with the floor of the compartment.

Soon as the plug is yanked, oil slops over the panel and dribbles down the front of the van. A real mess. And it tempts a man to skip the weekly (or 50 operating hours) check on those chillers.

But we plugged the problem with a fix that's nothing more than a short length of pipe—about three inches long—that screws right into the drain hole. A cap over the other end keeps the oil in place.

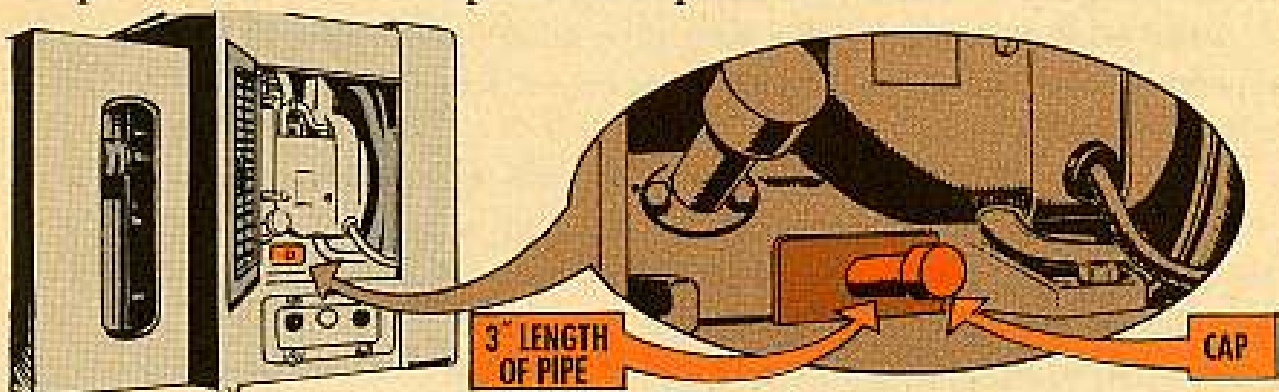

Comes drain time and a man can stick a pan or pail or funnel in position . . . back the cap off . . . and the job's as good as done without a drop lost. Neat and easy.

Sp2 F. M. R.

Dear Sp2 F. M. R.,

Your fix sounds as good as any I've heard. Make sure, though, the pipe doesn't stick so far out that it prevents the engine compartment door from closing.

When you put the pipe in the hole, put some paint on the threads and put it in to stay: Don't put paint on the outer (cap) end threads, tho, 'cause you want that to come off easier.

Also, you might grab some sheet metal and make a trough. The wide end would go up against the engine, with the narrow part pointed at the container that you're draining the oil into.

Connie

ARMY AIRCRAFT

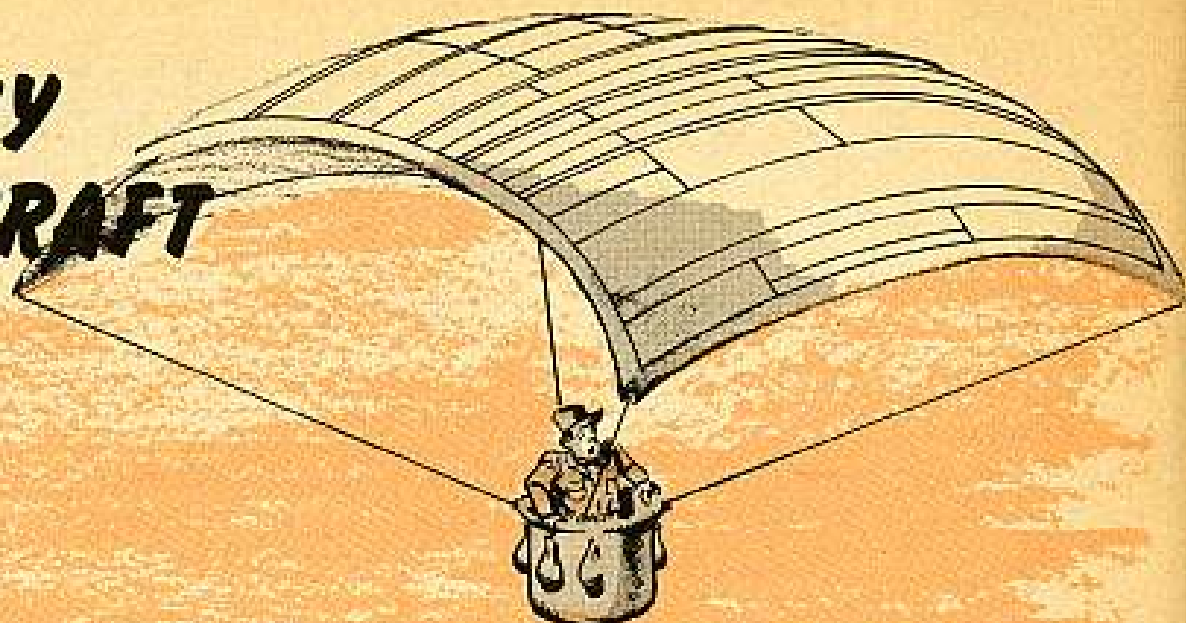

UP IN THE AIR WITH A UER?

AR 700-38 can be pretty tricky when you're submitting Unsatisfactory Equipment Reports on air items.

Section 2 of the AR gives you the lowdown on handling reports and exhibits for items belonging to the Transportation Corps.

A real good deal. But it seems some people have been going by Section 2 when reporting on equipment belonging to other services—like the Signal Corps, for example. Which isn't right.

Tech service material other than Transportation gets the treatment like it says in Section 1. Which means that exhibits and stuff to support the UER's either go along with the report or are kept real handy for inspection by someone from the tech service concerned.

OK, you say, but what about assemblies and such that have parts belonging to more than one tech service? No sweat. SR 700-50-5 with Changes 1 and 2 tells you which service should get the report.

AOCP? OH YEAH?



Some joker's always trying to pull a fast one, and generally it louses things up for everybody.

This time the sharpies have been getting too flip with their AOCP requisitions. Seems like any time they wanted a part in a hurry, no matter how trivial

it was, they'd slap in an AOCF requisition. Some even came in for rugs, ash-trays and wheel chocks!

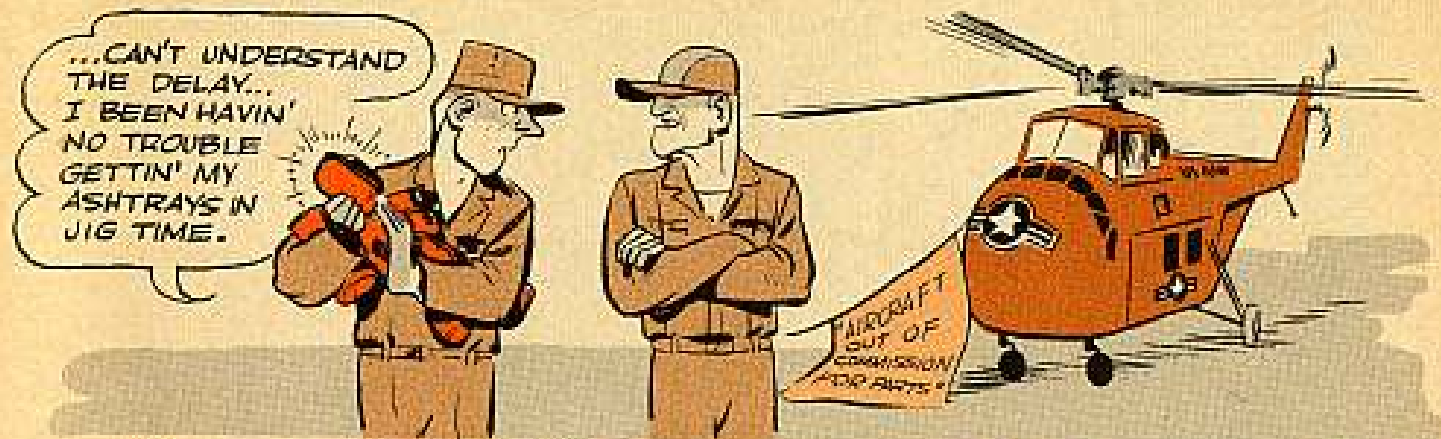

So, pretty quick the AOCF channels were jammed full of requisitions that should'a been routine or at least not beyond "Special". This slowed things down until guys who really had a genuine "Aircraft Out of Commission for Parts" were bein' kept on the ground while TSMC was chasin' ash trays.

Naturally, Casey lowered the boom. DA Circular 700-29 (5 Nov 57) lays down the law. Mostly it sez you will exhaust every other source of supply before you put in an AOCF requisition. And, it sez, you will ground the aircraft until the requisition is filled. And, it is the Old Man himself who has to see that this is done.

So—better you don't end up with an aircraft on the deadline because you got in a hurry for a new floor rug. The Man won't look kindly on this.

SHAWNEE FUEL CAPS

You all know that the TM's on your aircraft lay down the inspections you must make. And any air mechanic worth his salt is always willing to go a little beyond the minimums to be sure his bird is serviceable and safe.

Fuel tank filler caps on the Shawnees (H-21's) are a good example. TM 1-1H-21(Y)-6 tells you to check your fuel tanks for servicing and filler caps for security.

But a good crewman goes one step further and looks carefully at the bottom of the filler cap itself—since that spring pin hole in the cap has been known to wear itself oversize and let the whole works drop down into the fuel cell. Which leads to the devil's own job getting 'em out again.

Each time you gas up, take an extra look at your cap before you put it back.



CLEAN 'EM



Rusty, dirty, with maybe a touch of green mold?

It happens to the best of hand tools. Some lose their luster just from the sweat on a man's hot hand. Others catch a dose of "flash rust" from a quick shift in temperature or humidity. Not to mention such things as tar, grease, asphalt and just plain dirt. They make a good tool rough to work with.

But the right cleaner and preservative put on at the right time will keep rust and dirt on the run.

Ordinary paint thinner will get rid of most rust, and there's plenty of thinner in this man's army. As a matter of fact, that same paint thinner also will go to work on tar, asphalt and other "foreign agents".

But if you need a cleaning agent with a little more muscle (when a tool is really fouled with some heavy stuff), go to work with some crocus cloth, steel wool, or even a rag saturated with dry-cleaning solvent.

Might bear in mind, too, a couple of extra cleaning tips that come in handy for chrome-plated tools. The best bet is regular metal polish—which has a gentle abrasive in it that's guaranteed to clean and polish but not scratch.

Tip number two concerns paint and how to dissolve it. Strong stuff is needed here—varnish or paint remover of the organic solvent type. And check the small print on that name... "organic solvent type". It's the only kind of remover built to dissolve paint once it's hardened. The smallest batch available is a 5-gal container, so snoop around for a sample and you'll have all you need.

But the cleanest, shiniest, newest wrench or pair of pliers will be just another knucklebuster 'less it has something to **keep** the rust and stuff away. So to finish the job—make with the oil.

What grade a man uses, naturally, depends on such things as climate, humidity and (many, many times) whatever oil is handy.

AND COAT 'EM



In most cases, regular engine lubricating oil (OE-10) will hold the line against corrosion and "foreign agents".

But good tool handlers always keep an eye open for new break-throughs. Hot and humid weather, along with salt air, usually speeds up rust action by several hundred percent. For extra protection against that kind of damage, a coating of PL Medium will put you in the clear. It's reinforced with some chemical gimmicks that make it stay put and seal tight.

Whatever oil is used, though, a well-soaked rag is the way to rub it in.

And remember—all the preservative in the Army won't clobber corrosion unless you take off **all** the rust first.

TO CLEAN

Item	Federal Stock Number	Quantity
THINNER, PAINT, Mineral Spirits	8010-246-6111 (Eng)	1 pt
POLISH, METAL	7930-267-2978 (QM)	1 pt
REMOVER, PAINT, Alkali-Organic-Solvent-Type	8010-283-0511 (Ord)	5 gal

TO COAT

Item	Federal Stock Number	Quantity
LUBRICATING OIL, General Purpose, PL Medium	9150-231-3261 (QM)	1 qt

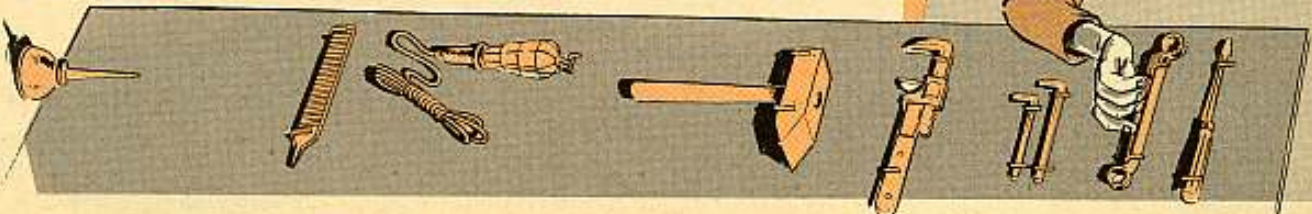



They Belong

Doing your preventive maintenance services on your Chemical equipment can be a snap if you have the new DA Forms, plus TM 3-313, plus the technical manual for your particular piece of equipment.

Say, for instance, you have M3A2 smoke generators. You now have DA Form 2016, "Record of Operation for Mechanical Smoke Generators." This form is to your smoke generator what your trip ticket is to your truck. It's a record of how things shape up before, during, and after operation of your smoker.

It will remind you of what your equipment needs. If a part needs to be replaced, then your 2016 should show it. It can clue you in when you should send for help from higher echelon. Here's how your 2016 works—

RECORD OF OPERATION FOR MECHANICAL SMOKE GENERATORS

1. Here's where the date goes. If you're running your smoke generator on 6 Mar 1958, then put it down.

2. The nomenclature goes here.

3. The model number of your smoke generator goes here.

4. Don't forget the serial number.

5. Your organization belongs here.

6. Total time operated belongs here. Keep a running record in the "Remarks" section.

DATE	6 MAR 58
UNIT OR LOCATION	
NAME OF GENERATOR	MECHANICAL SMOKE GENERATOR
MODEL	M3A2
Serial No.	71324
TEST TIME	
OPERATOR	1st Lt S. D. [unclear]
MATERIALS CONSUMED (GALLONS)	3
AMOUNT OF OIL	40
REMARKS	



DO YOUR "BEFORE OPERATION" SERVICES AND ENTER THEM HERE

BEFORE OPERATION	LEADER	DATE	TIME	IN APPROVAL
FUEL	<input checked="" type="checkbox"/>			
FOG OIL	<input checked="" type="checkbox"/>			
IGNITION GROUP	<input checked="" type="checkbox"/>			
PRESSURIZING SYSTEM	<input checked="" type="checkbox"/>			
TOOLS AND EQUIPMENT	<input checked="" type="checkbox"/>			
REPAIR PARTS	<input checked="" type="checkbox"/>			
Visual Inspection	<input checked="" type="checkbox"/>			
Cleaning	<input checked="" type="checkbox"/>			
Remarks	<input checked="" type="checkbox"/>			

Together

Now take a look at the preventive maintenance services. You use your TM 3-431 to see just what you're supposed to do and how you do it. First you have your Before Operation services. If the item is OK you put a ✓ in the blank space. When some service is needed, put an X in the space. But if something was needed and you took care of it, then put a circle around the X like this ⊗.

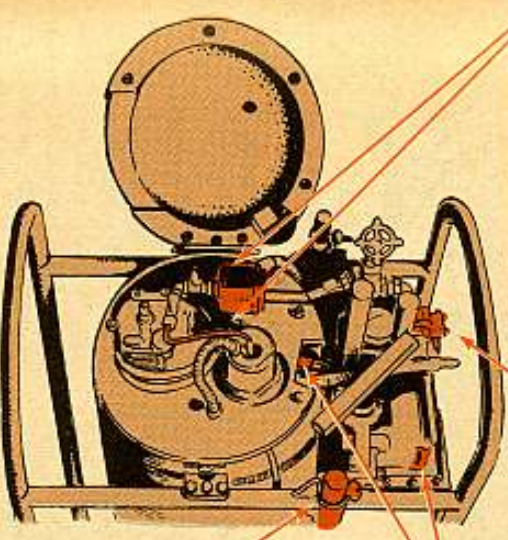

FUEL—You check your supply to make sure the tank is full and the fuel level in the float bowl is where it should be. Drain any water from the fuel tank and from float bowl. Take a look at the fuel lines to see that there are no leaks. Check your fuel hose and replace if it's bad. The valves and cocks ought to turn smoothly, but leave 'em all closed after you check.

FOG-OIL—Full and plenty. The fog hose has to be in good shape. Make sure oil standpipe assemblies and valves are in good shape and not leaking. Put in new gaskets if you have to. The valves should be in OFF position—when smoker's not running.

IGNITION GROUP—Check your magneto, spark plug, and ignition cable to see that they're secure and put together. You'll want to replace any worn-out parts. If the smoker hasn't been run for a long time, or just came out of storage, check the magneto breaker points to see that they're not pitted and are in good shape.

PRESSURIZING SYSTEM—Check your air pump to make sure it's secure and put together all right. See that the valves turn smoothly. Leave all of 'em in the OFF position.

TOOLS and EQUIPMENT—Make sure you have 'em all and that they're in good condition.

PIPPING—No leaks!

NUTS, BOLTS, FITTINGS—Tight!

8. Now that you've finished your Before-Operation services, put your "John Henry" in this space.

NAME: *John Henry*
 UNIT: *14R*

9. Then comes your During-Operation services. You've got to get your ear trained for screwy noises while your smoker's working. When troubles bug you, fix 'em or holler quick before they get worse.

14R 58
 UNIT
 324
 OPERATOR
 SPECIALIST

PREVENTIVE MAINTENANCE SERVICES (Specified in detail in the technical manual.)

BEFORE OPERATION	DURING OPERATION		AFTER OPERATION	
	✓	✗	✓	✗
FOG OIL	✓		✓	
CLEANLINESS	✓		✓	
LEAKS	✓		✓	
UNUSUAL HEAT, SPEED, NOISES	✓		✓	
PREPRESSURIZING SYSTEM	✓		✓	
ENGINE VALVE REPLACEMENT	✓		✓	
CLEANLINESS	✓		✓	
RECORDS	✓		✓	

FOG OIL—Keep an eye on your drum, and have another one ready to hook up when you've run your smoke generator on hour.

CLEANLINESS—Keep it clean and you'll save headaches.

LEAKS—You don't want any—either fuel or fog-oil.

FUEL FEED and OIL FLOW—Adjust 'em as necessary.

FUEL—Fill your tank and check your reserve.

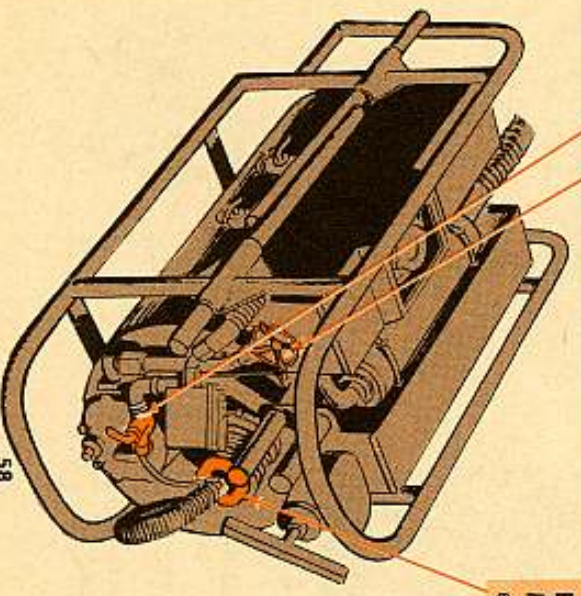

UNUSUAL HEAT, SPEED, NOISES—If you run your generator without enough fog-oil, the unit may heat up. Open the oil metering valve gradually and she'll cool slowly. When the engine's overloaded with fog-oil, you'll hear it running faster and it may get noisy. You'll see fog-oil coming out of the smoke outlet nozzles. When this happens, cut the oil flow back pronto.

RECORDS—Keep your operational records complete.

ENGINE VALVE REPLACEMENT—Replace it when necessary.

PRESSURIZING SYSTEM—When you're running in freezing weather, you've got to drain moisture from the pressurizing valve by turning the draincock handle counterclockwise. You do this every 20 minutes and right after you shut down. Another place you have to drain condensed water is from the pipe tee—by removing the air valve when the water has been drained, replace the valve. Same thing goes for the automatic shut-off valve. Just screw the plug out but don't forget to put it back.



There are a few things to do during At-Holt (even though you don't have to note them on your Record of Operation). Give your smoke generator the once-over (not too lightly). Take a look at your fuel and fog-oil supplies to make sure you've got enough. Look for fuel and oil leaks. See that your smoke generator is secure. Look at the fog-oil shut-off valves, the air shut-off valve, and the fuel shut-off cock under the float bowl to make sure they're closed.

10. You've finished your During-Operation services so your name goes here.

14R 58
 UNIT
 324
 OPERATOR
 SPECIALIST

11. Last but not least comes the After-Operation services.

PREVENTIVE MAINTENANCE SERVICES (Specified in detail in the technical manual applicable to the model to be serviced.)

BEFORE OPERATION	DURING OPERATION		AFTER OPERATION	
	✓	✗	✓	✗
SHUTDOWN PRECAUTIONS	✓		✓	
FUEL AND FOG OIL	✓		✓	
CLEAN EQUIPMENT	✓		✓	
IGNITION SYSTEM	✓		✓	
ENGINE AND EQUIPMENT OILS	✓		✓	
REPAIR PARTS	✓		✓	
VALVE REPLACEMENT	✓		✓	
PROTECTION	✓		✓	

KEEP THE FORM WHERE YOU CAN REEFER TO IT EASY!

SHUTDOWN PRECAUTIONS—Turn your fog-oil shut-off valve to the OFF position, but keep the engine running until smoke stops. Then stop it.

CLEAN EQUIPMENT—Check the spark plug and replace it if you have to. If not, clean it with dry-cleaning solvent. Clean your engine head assembly with dry-cleaning solvent (and be sure you check the engine valve while you're at it). You still need that dry-cleaning solvent—clean the metal surfaces of your smoker with it. Then remove the fog-oil hose from the oil standpipe assembly and drain the oil from the hose. You've got a handy plug fastened to your hose, so screw it into the coupling.

Take the pressurizing hose off your oil standpipe assembly and clean the hose's outside with dry-cleaning solvent. Stow it on your generator.

Better take the oil standpipe assemblies out of the fog-oil drums. After you clean the standpipes with solvent, stow 'em in the storage tubes. Use the bung wrench to tighten the bungs back into the fog-oil drums.

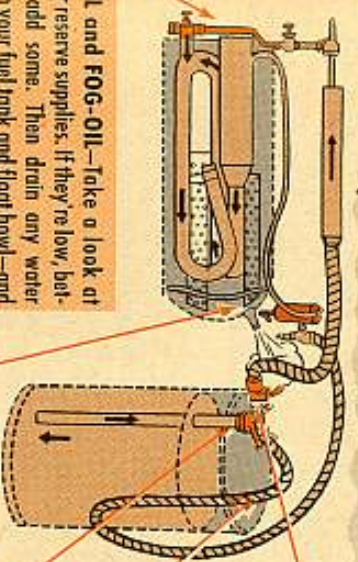

FUEL and FOG-OIL—Take a look at your reserve supplies. If they're low, better add some. Then drain any water from your fuel tank and float bowl—and fill your tank. Take the plug out of your automatic shut-off valve so the water will drain, but be sure and put it back in. Drain collected moisture from the pressurizing valve.

IGNITION SYSTEM—Check your ignition cable for cracks and tightness.

RECORD OF OPERATION FOR MECHANICAL SMOKE GENERATORS (TM 2-22)				DATE 6 MAR 58	
EQUIPMENT IDENTIFICATION		MODEL	SERIAL NUMBER		
MECHANICAL SMOKE GENERATOR		M3A2	71324		
CHEMICAL CO.		TOTAL TIME OPERATED (Hrs)	MATERIALS CONSUMED (GALLONS)		
		1 hr.	KEROSENE	FOG OIL	OTHER
			3	40	
<small>Use appearing in any of the following boxes indicates that the operator has performed services specified applicable to technical manual.</small>					
Signature of Operator		Signature of Operator		Signature of Operator	
S. Domingos		Sgt. Frank S. Domingos		Sgt. Frank S. Domingos	
<small>PERFORMED MAINTENANCE SERVICES (Specified in detail in the technical manual applicable to the model to be serviced)</small>					
<small>LEGEND: ✓ - No service required; ✗ - Service required; ⊙ - Service performed.</small>					
OPERATION	DURING OPERATION		AFTER OPERATION		
FOG OIL	✓	FUEL	✓	SHUTDOWN PRECAUTIONS	
FOG OIL	✓	FOG OIL	✓	FUEL AND FOG OIL	
EXHAUSTOR	✓	FUEL FLOW AND OIL FLOW	✓	CLEAR EQUIPMENT	
ENGINE	✓	LEAKS	✓	IGNITION SYSTEM	
ENGINE	✓	VIBRATIONAL HEAT, SPEED, NOISE	✓	TOOLS AND EQUIPMENT (ODM)	
ENGINE	✓	PRESURIZING SYSTEM CONDENSATE	✓	REPAIR PARTS	
ENGINE	✓		✓	VISUAL INSPECTION	
ENGINE	✓		✓	PROTECTION	
ENGINE	✓		✓		
REMARKS					
15. Screwdriver missing HOURS RUN: 0800-0830 0900-0930					

TOOLS and EQUIPMENT—Run down the list of tools you're supposed to have and see that you've got them all. You need 'em clean and in their right places.

13. Here's where you tell how much gasoline she used.

14. Same for fog-oil here.

12. Sign your name in this space to show that you've done the After-Operation services.

PROTECTION—After your smoker's cooled, put its canvas over it. Store the fuel and fog-oil in a safe area.

You can use this space to explain any of the items listed in the Before, During, After Operation. Maybe your screwdriver was missing from your tool set. Better call attention to it here.



VISUAL INSPECTION—Give it the once-over to make sure there're no fuel or oil leaks, no loose or missing nuts or bolts, and no bent, cracked, or broken parts. The valves should turn smoothly, but leave 'em closed.

REPAIR PARTS—Check your repair parts to see that there're enough in good shape, and stowed the right way in the right places. Get replacements if needed.

You keep this record of operation for two months in the Equipment's Jacket File and then destroy, like it says in AR 345-292.

CONTRIBUTIONS

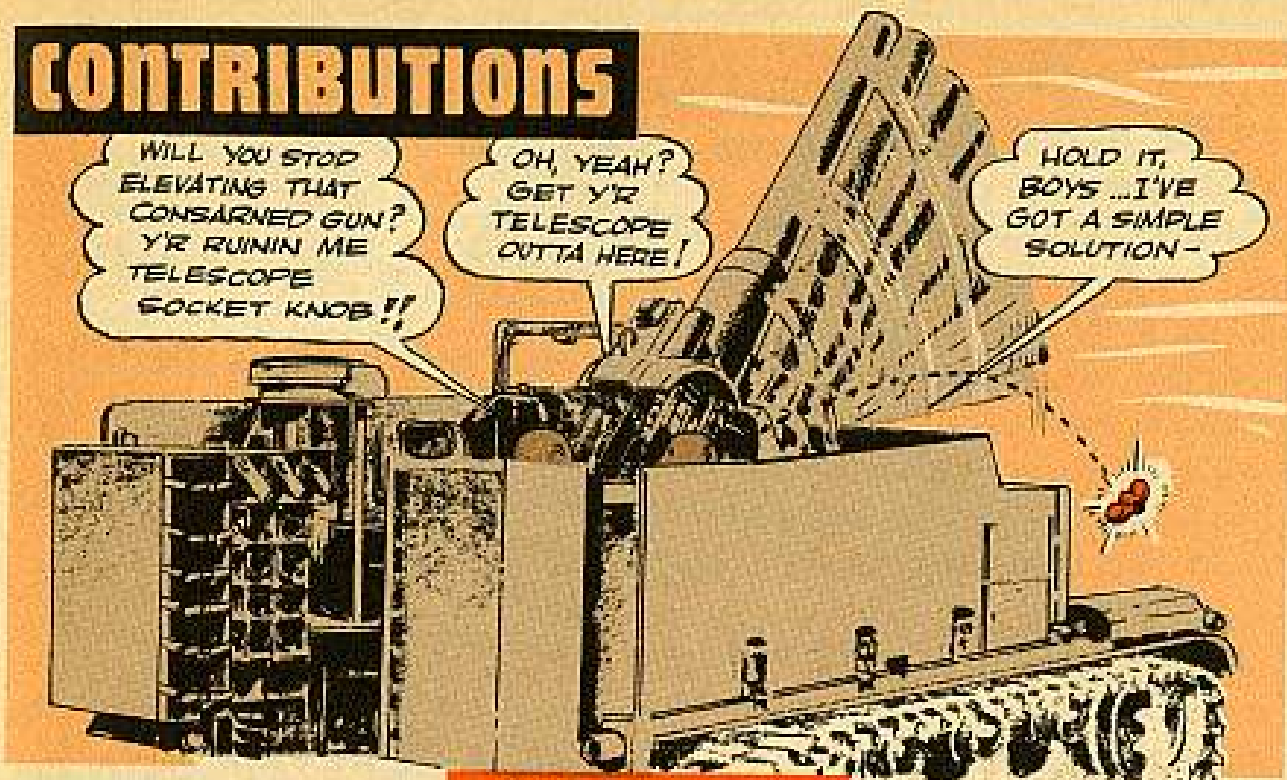

ONE SIDE, BUD

Dear Editor,

Just like grandpa's whiskers, the gunner's firing control boxes on our M44 Self-Propelled Howitzers were always getting in our way until we came up with this simple protector.

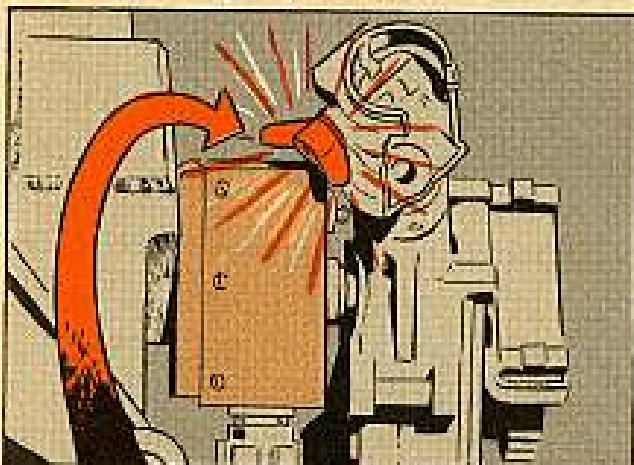

Seems that when the howitzer was being raised to its top elevation, the wing of the telescope socket knob (on the panoramic telescope mount) was hitting the firing control box. This usually damaged the knob so badly that we couldn't turn it to get the telescope out.

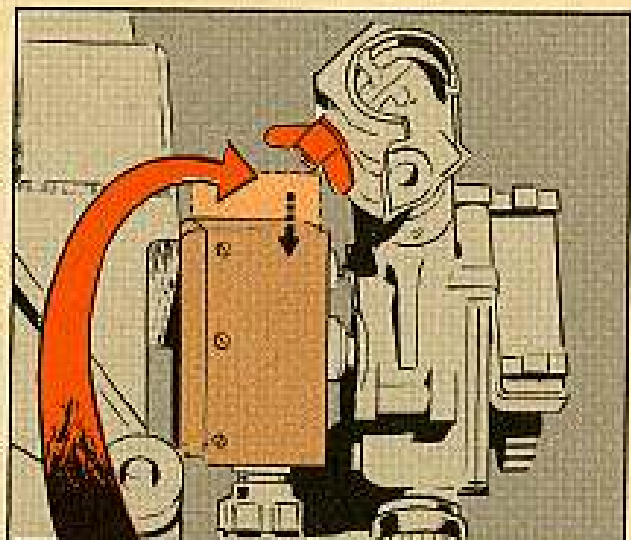

All we did was take the box off and reposition it 2 inches below where it originally was. This way it's clear of the wing knob when the gun is fully elevated.

SFC Donald Hart
Idaho National Guard

(Ed Note—A good move. TM 9-7004, para 236, also has a good procedure for removal and installation of the control box.)



FROM AN OLD PRO

Dear Editor,

If there's one touchy and temperamental honey, she's your immersion heater on a cold, damp day. And what's so bad is that you usually have to tackle three of 'em at the same time.

Unless they're handled with kid gloves, they'll freeze up on you, refuse to cooperate, blow their stacks, and in extreme cases, smack you right in the kisser.

But all is not hopeless. After many a black eye and countless frustrations, I've found the following technique works pretty well. It's sort of a two-pronged attack, and darn few heaters have been able to resist it.

The most important thing, of course, is to get the heater in the mood to heat up for you. So the longer you can keep the burner rod in the flue, the better off you are. This heats the air, causing the warm air to rise to the top, making room for the cold air to enter, so it can be heated and rise. This flow of air sets up a draft, which is needed to get things going.

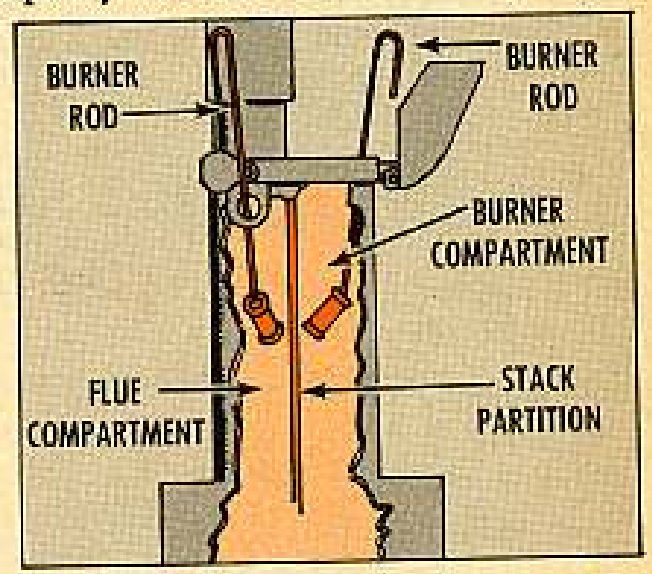

So far, so good. But a lot of men lose out here by failing to strike when the iron is hot, so to speak. They fool around while shifting the rod to the burner, so the burner cools down and they get a pretty cool reception. Not only that, but the drops of gas gang up on them, and when the gas does ignite, they get a "flashback."

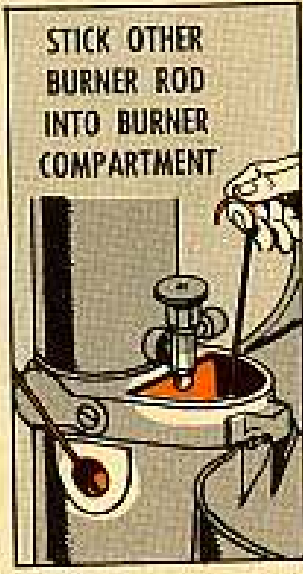
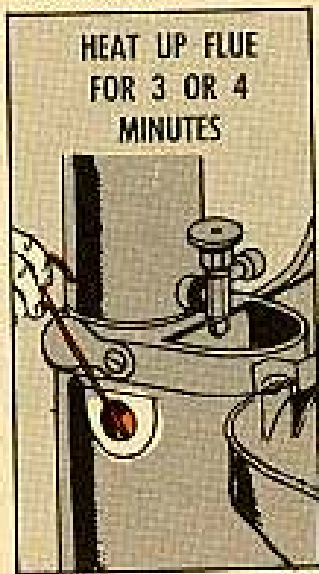

Now here's where the two-pronged attack comes in. Since you usually have more than one rod around, the best deal is to use two of 'em at one time, like this:

With one rod, heat up the flue for three or four minutes. Then, without taking out the first rod, slip another one into the burner compartment. Your heater will go for it in a big way, and you're in business with no sweat at all. All heat and no bother, you might say.

'Course, you have to be pretty nimble to handle both rods at the same time, but you get the hang of it after a while. I'd advise beginners to team up and

work in pairs, though. One man to do the pre-heating and the other to fire the heater. That way nobody gets all tuckered out.

SFC Donald Juan
APO 227, N. Y.

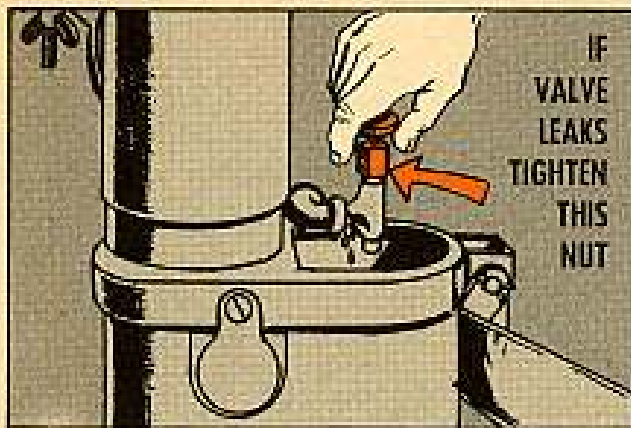

(Ed Note—H'mmm. No doubt about it. And here's some more good advice. Before you do anything, give the fuel valve a good inspection. A leaking valve can get you in trouble every time. If there's a leak, tighten the packing gland nut on the valve. If that doesn't do it, replace the valve.)

DIM, BUT WITTY



Dear Editor,

If the headlight dimmer switch on the M-series wheeled vehicles is pushed down and won't come back up, or comes back up real slow, don't blow a fuse. Chances are dirt has got around that switch and worked its way between the housing and the dimmer button. Or, some guys going ape when painting the floor board may have dripped some drops down in there.

So, all you have to do to fix it up is this:

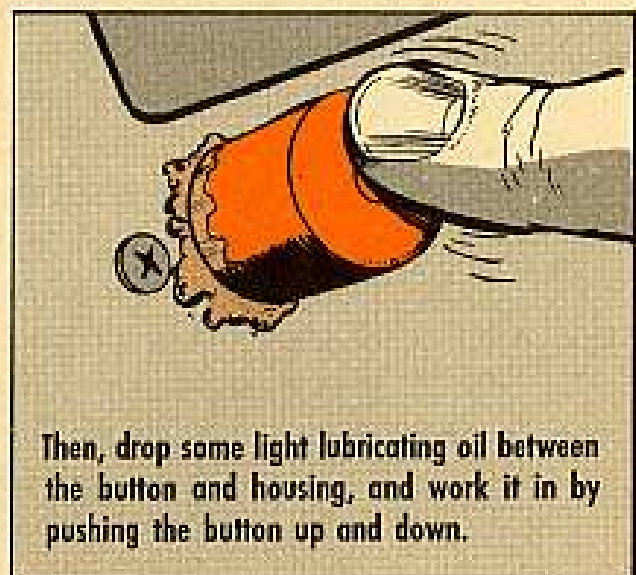
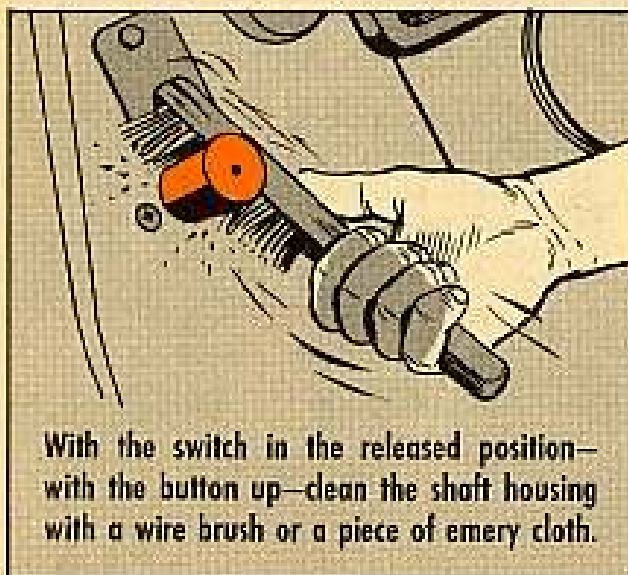

You'll be surprised at the result.

SFC Joseph R. Wargo
Ft. Ord, Calif.

(Ed Note—Surprised or not, that'll start that dimmer switch working again. For a real neat job, wipe off any excess oil.)

THESE NUTS WON'T CRUSH

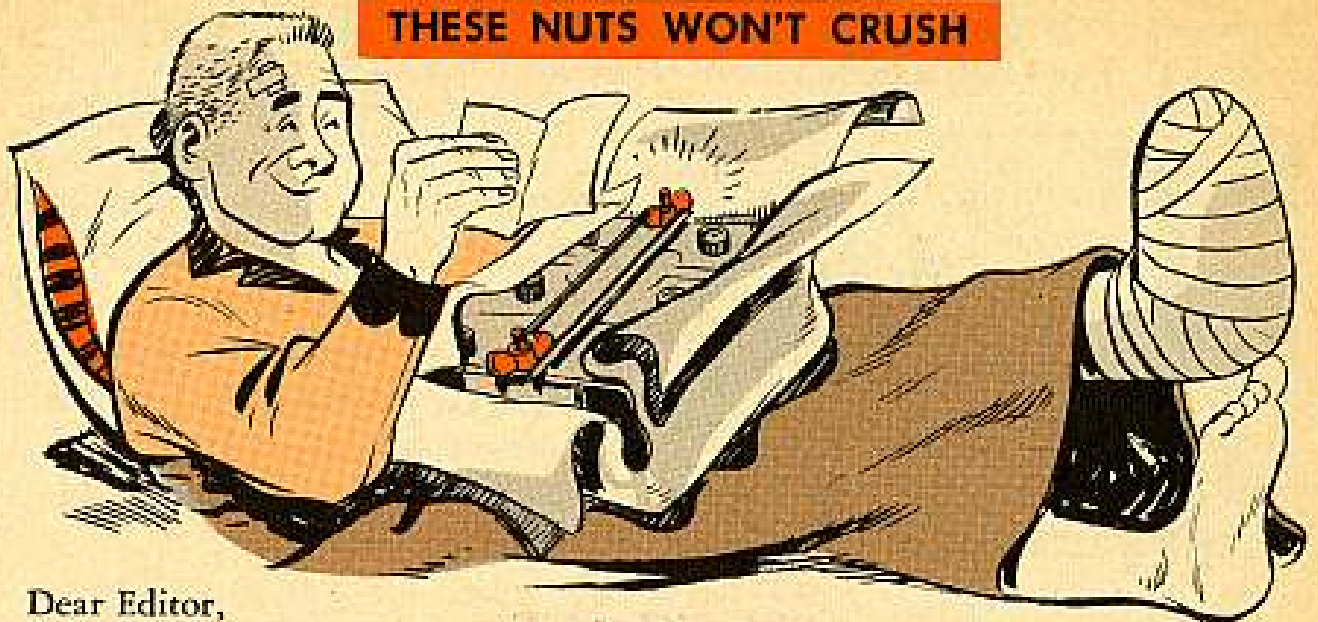

Dear Editor,

We had a pretty serious accident here, which led to an investigation, which led to a solution so that the thing won't happen again.

One of our men went to lift a 6TN battery out of a G749 2½-ton truck. The handles, which were corroded to beat the band, snapped, and the battery came down on his foot. The poor guy didn't walk for a week.

Our searching brought out the fact that the hold-down bar, which holds the battery tight, was being tightened down too much. The bar rests on top of the handles. As it was being wrenched down, the handles chewed into the sealing compound between the top of the battery and the electrolyte. This gave way to acid leaks, which covered the handles and corroded them. Also, we found that, because of this, a lot of batteries were steadily discharging.

So, what we did was remove all the nuts from these hold-down bars and replaced them with wing nuts. Then, the order went out—the wing nuts were to be tightened down by finger only. Finger tight is enough to hold the batteries in place, without crushing the sealing compound.

Now, our handles don't corrode, and our batteries keep their charge.

Cpl M.J.S.

New Jersey National Guard

(Ed Note—The right kind of preventive maintenance would call a halt to that leakage, of course. You've got to be mighty careful with that bar-type hold-down. If you tighten 'er too much, you get the kind of damage you talk about—if you don't tighten 'er enough, you still get damage from the battery hopping around. You've got a good idea—but, every so often, give those wing-nuts a tweak to make sure they're holding right.)

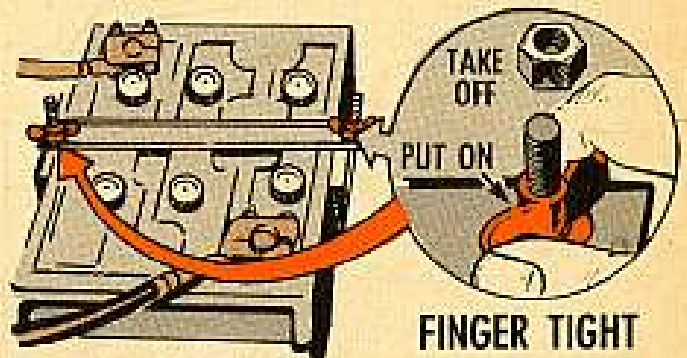

Connie Rodd's

BRIEFS

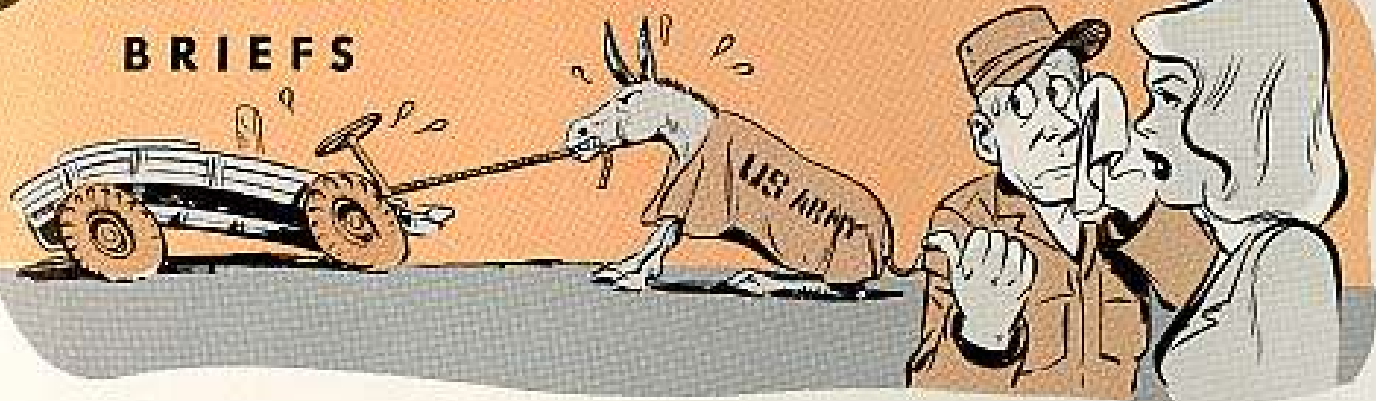

Heat does it

Next time you get ready to spray lacquer, try putting the cans in some warm water for a coupla minutes. The heat helps keep the lacquer right for going through the nozzle.

It's in the TB

How're you making out with the M39 sight—the one used with the M20-series 3.5-in rocket launchers? You'll find the scoop on it in TB 9-2002-2 (13 Nov 57).

For a better Buda

First chance you get, see your maintenance support group about beefing up your Buda tractor, MHE-135. MWO 10-1666A-1 (4 Nov 57) calls for a fistful of fixes, ranging from new front springs to the clutch housing. And it's marked Urgent.

Device advice

You Nike-Ajax guys oughta latch on to a copy of TB Ord 1008 (10 Dec 57). It tells you about getting rid of the M30 safety and arming device after you've had it for two years. The M30's also used with the Nike-Hercules missile.

Swing low

Those brake lines on your XM329 Honest John rocket trailers are lying awfully low to the ground at the rear "T" connection. There's no sweat when you're running on good roads, but you have to be awfully careful when going cross country or else you could rip 'em out.

M9 for A6

You want to fire blanks in your 1919A6 .30-cal machine gun? Then you want the M9 blank firing attachment that's listed in Ord 7 SNL A-6 (23 May 57). FSN 1005-716-2790 gets you the two-part attachment.

Aspirin, anyone?

Hold it! Those new football-type helmets for combat vehicle crewman are **not** ready for issue—even though you'll find them in SM 10-5-8415 (Ch 3). A problem's cropped up on their development. Meantime, tankers, hang on to your requisitions.

7C to MWO 7B's

Don't let TB Ord 1004 and TB Ord 1005 slip by you if you're in a Nike-Ajax or Corporal outfit. Both TB's give you the low-down on the field changes that have been converted to Department of the Army MWO's for each system. The TB's are dated 12 Nov 1957.

Your MAINTENANCE BALANCED?



DO THE EASY JOBS
GET TOO MUCH?



...AND THE TOUGH
JOBS... TOO LITTLE?

To Keep Your Equipment HEALTHY...
TAKE CARE OF 'EM ALL!