

Issue 60

**PS**

1957 Series

**THE  
PREVENTIVE  
MAINTENANCE  
MONTHLY**

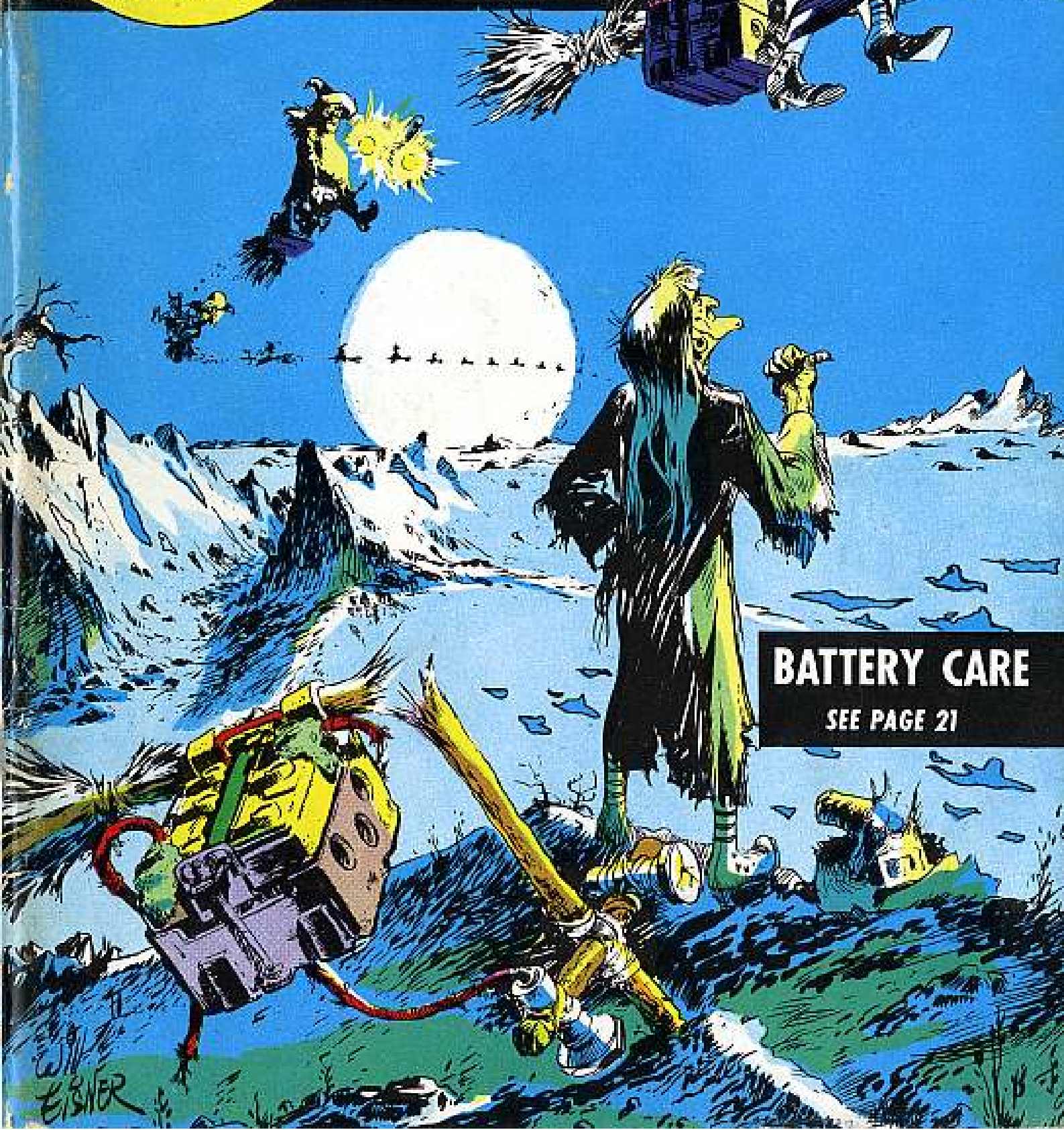

**BATTERY CARE**

SEE PAGE 21



# AVOID HYDROSTATIC HEADACHES IN TANK ENGINES

"Hydro" means liquid, and "static" means at rest or rigid. Put 'em together and you have the best tank buster since the HEAT round.

Tank engines can get hydro-shafted at the drop of a starter switch. Suppose a green driver steps in and starts his tank without any kind of a check. Here's what may happen:



While his tank was parked, gasoline could have come sneaking in through an open intake valve and filled up a cylinder. Now, the driver throws the "mags" on and starts the engine.



Several cylinders fire... the piston in the flooded cylinder starts its up (on compression) stroke. Trouble is, the valves have closed, and all that fluid is trapped in the cylinder.



**WHAM!** The piston hits a block of fluid that's as tight as a trapeze artist's hand-shake. Something has to give and it isn't the gasoline. It's usually the connecting rod. That, brother, is hydrostatic lock.

You can help prevent hydrostatic damage by making an easy check and taking a few operating precautions. Before starting your tank...



Keep the magnetos OFF...



... hit the starter a couple of ON, OFF, ON, OFF pushes (not too rapidly)....



... till you know that all the pistons have been shoved up and down at least one full stroke.



If your engine ker-chings over a couple of times and jams, she's probably locked up tight, hydrostatically speaking. When this happens, the starter clutch will start slipping and you'll hear it sound off with a loud "whine." If the engine turns over freely then you're safe from hydrostatic lock.

This easy check tells that the cylinders are not full of fuel—or at least that there isn't enough to lock up the engine—and it'll help reduce damage caused by hydrostatic lock. TB Ord 459 (1 Jul 52) and TB Ord 558 (14 May 54) give the official rundown on starting series 895 and 1790 engines.



But don't get fooled. Hydrostatic lock can still happen even if you start the engine right. Fuel from over-priming and "pumping" the gas pedal can lie in the intake manifold waiting to trap the unwary driver even after the normal check for hydrostatic lock. This



fuel can get sucked into a cylinder during engine pick-up and lock a cylinder, bend the connecting rod, and clear with-out the driver knowing it. Eventually the bent rod will cause an engine failure.



By checking any "lock" causes with your unit mechanic, you should be able to head off this kind of damage:

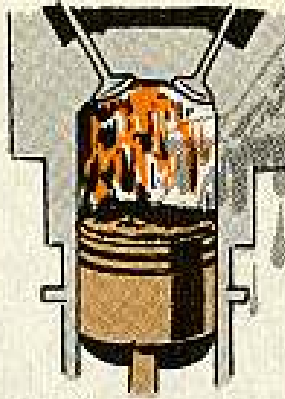
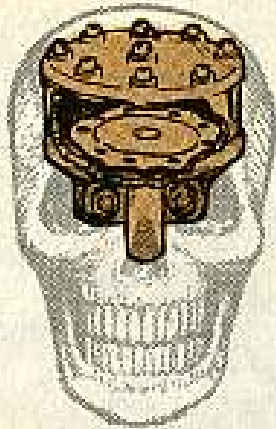

If you're checking out a new tank, or one that's just come from storage, there are two items that can hydro-stack the deck against you. First, a bum fuel pump diaphragm. Second, preservative oil that was left in the cylinders and manifolds when the tank was "fogged" for storage.

A leaky fuel pump diaphragm on your M41's and 42's can let gasoline seep through the pump vent line, through the manifold, and past an open intake valve. Clues to a bad diaphragm are gas in the crankcase and an engine that runs as though it has ignition or carburetion trouble. (Bad diaphragms are found more often in tanks that aren't used much or have been in storage.) If the ignition system and carburetor check out all right, try replacing the pump. And change your

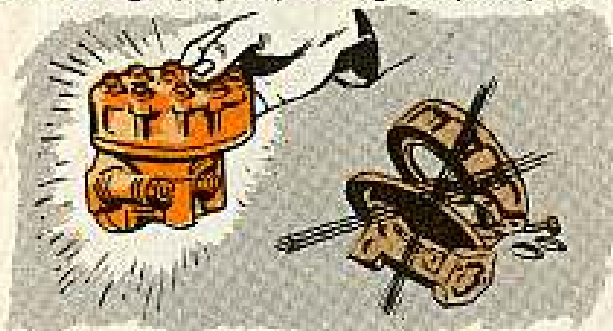

oil — gas in your crankcase will dilute the oil to a point that'll do severe damage and cause crankcase explosions.



About the worst thing you can do to your tank's fuel system, especially in warm weather, is to cream it up by overfilling the fuel tanks. If you overfill on a cool evening, next day when that gas warms and expands, it'll go pouring out of every hole and through every tube it can find. It can wind up flooding a cylinder or two if your carburetor's needle

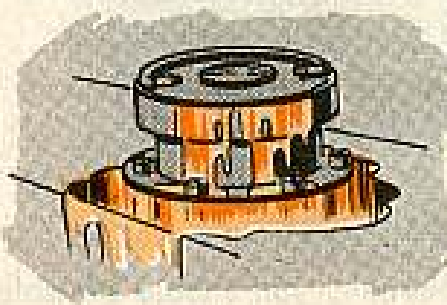
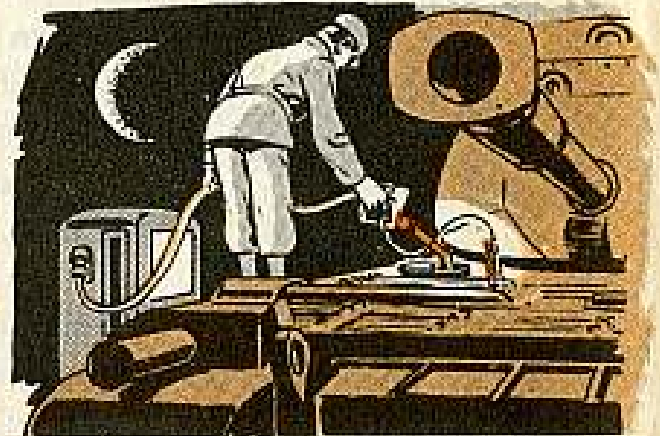

valves are unseated or its floats are busted. This may sound like a lot of "ifs" — don't take a chance, because it is happening. To be safe, leave an air space between the top level of the gas and the top of the tanks when filling 'er up (your TM says how much). That plus your pressure relief gas cap should take care of any expansion when the sun really gets hot.

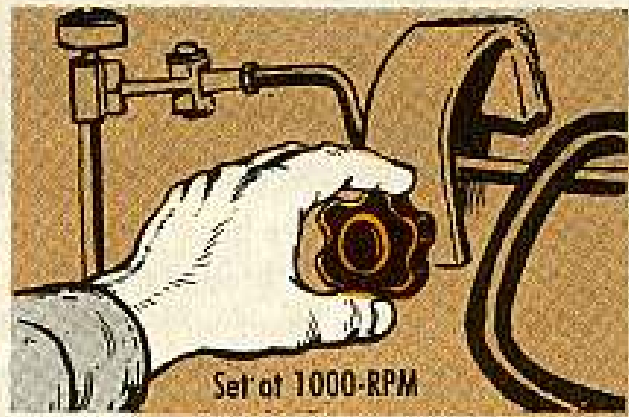

Get the right amount of gas into that engine and she'll run smooth. Use your primer pump only when the engine is turning over. When the engine starts, use the primer pump to even out that idle. Set the hand throttle at 1000-RPM and leave it there until the engine's warmed up. Don't use the accelerator till you're ready to go. Goosing it won't help a bit and can cause damage. Step on her just enough to get smooth driving power.

When you turn your tank's engine off, use your degassers. If they won't stop it, get suspicious quick. If the degasser trouble's not in the external electrical hook-up you may need to replace the carburetor.

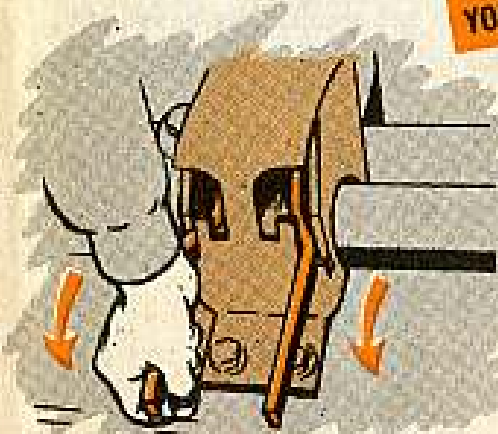
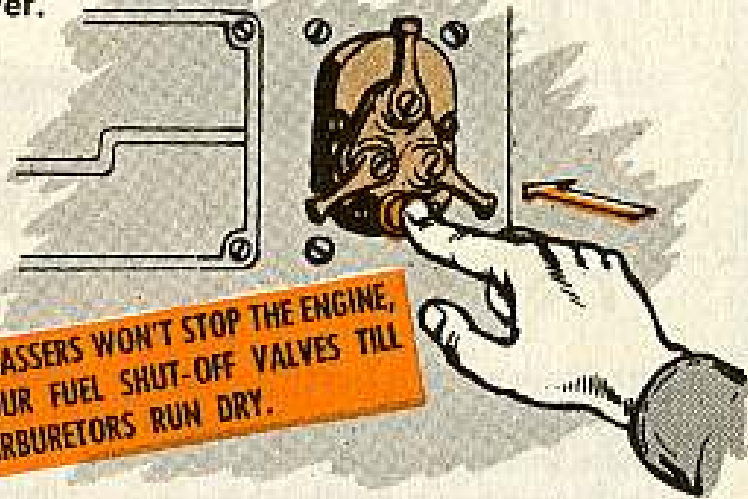

It takes a little more time, but while you're making your after-operation checks, drain that fuel filter. It catches a lot of trash that could easily foul up your carburetor, jam those needle valves open, and let raw gas seep into your engine.

Make sure your primer's closed and your fuel shut-off valves are OFF when you wrap your tank up for the night. TB Ord 576 (27 Aug 54) tells you how to handle those fuel shut-off valves.

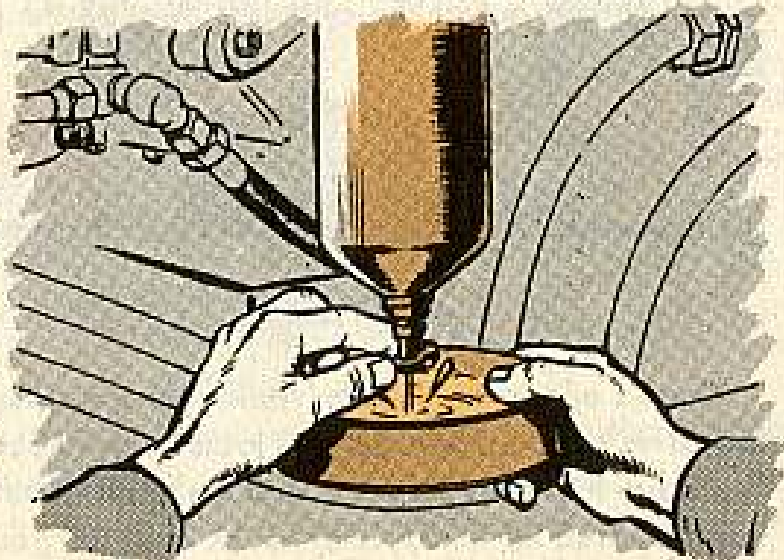

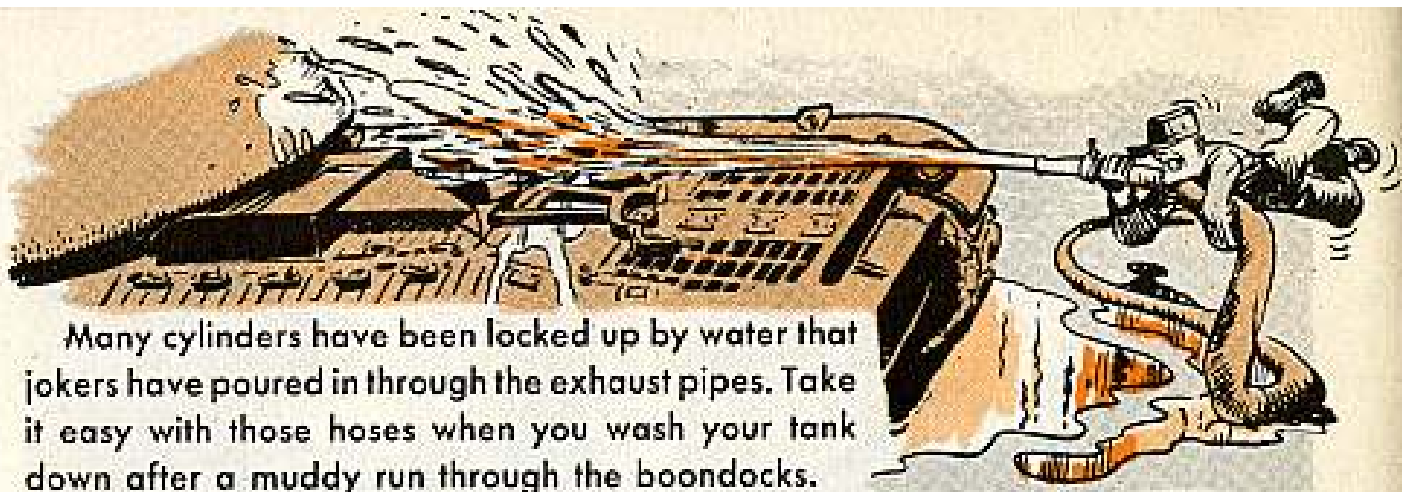

Many cylinders have been locked up by water that jokers have poured in through the exhaust pipes. Take it easy with those hoses when you wash your tank down after a muddy run through the boondocks.

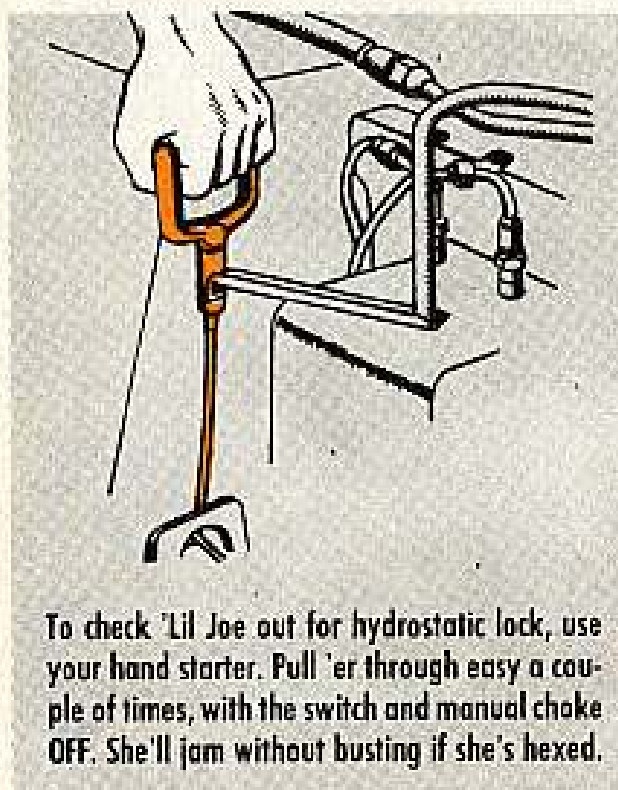

To check 'Lil Joe out for hydrostatic lock, use your hand starter. Pull 'er through easy a couple of times, with the switch and manual choke OFF. She'll jam without busting if she's hexed.

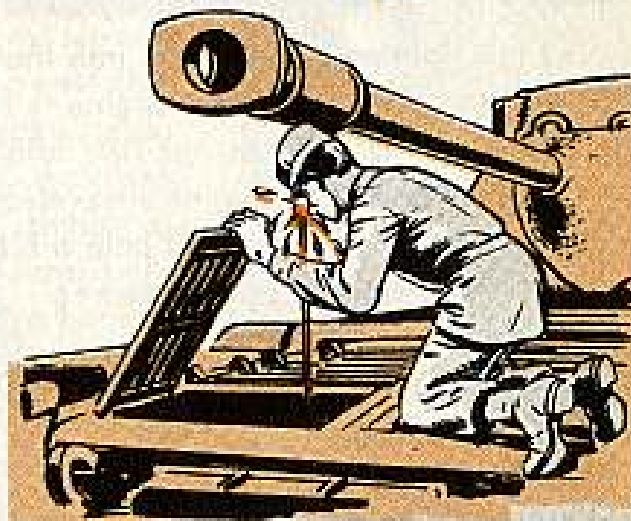

If you're preparing a tank for shipment by rail, trailer or otherwise, make sure the fuel tanks aren't overfilled and the shut-off valves are closed. Vibration from the ride can unseat the float valves and gasoline can be fed into the manifold.

Whether the engine's locked up by gasoline, water or oil, you or your unit mechanic can get the stuff out. Take the spark plugs out and crank the engine with the mags off...till all pistons have gone a full stroke each way. The fluid will be forced out of the cylinders through the plug holes.



There's one more thing to remember—a seized piston can act like hydrostatic lock. This happens when a part jams from heat or lack of lubrication. If you think you have hydrostatic lock...and if she still acts jammed after the cylinders have been cleared of fluids...let 'er sit and call your mechanic—quick.

# Ordnance Tool Story

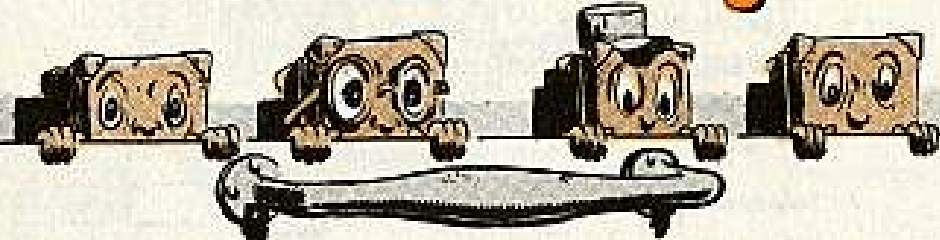

You don't have to be told about your tools. You already know about 'em—what they'll do and what they won't do.

Sure, there are all sizes and shapes—common and special, or what have you. You find certain jobs take certain types.

Have you ever wondered just why you have one kind and your buddy in another outfit another? Well, here's the answer—

Your TOE and SNL's tell you just what tool sets you need for your organizational maintenance. For instance, you might have:



Organizational  
tool sets,



Military occupational  
specialty (MOS)  
tool sets,



Special tool  
sets

and such items as test sets, parts cabinets, etc. Just depends on the type and amount of equipment you have.

So you'll know just what tools you're supposed to have...and where they're listed, here's a run-down:

## Operator (1st Echelon)

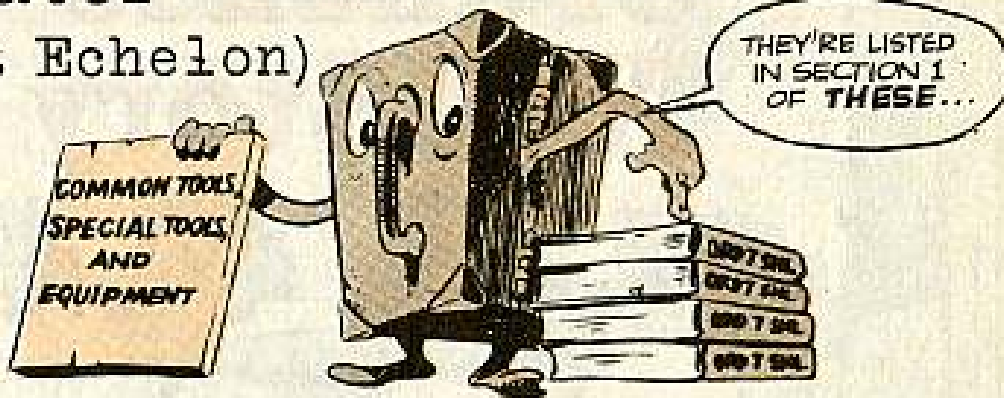

Your 1st echelon tools are a part of the on vehicle material (OVM). They go right with the equipment because they're the things needed by the driver and crew for maintenance. Or in the case of your weapon, there are tools and accessories to go with it, too.

Now, take a look at where your 2nd echelon tools are listed...

## Organizational Maintenance (2nd Echelon)

Common tools



Common tools (MOS specialists)

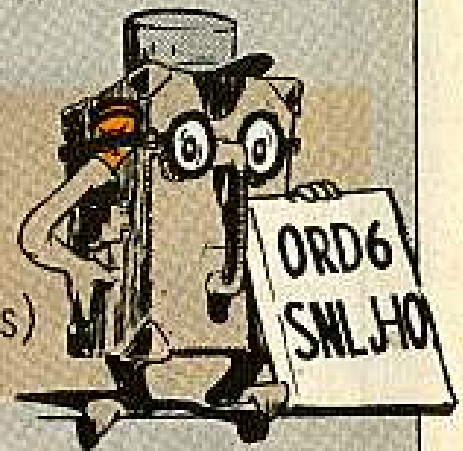

Additional special tools and equipment



Special tool sets for guided missiles

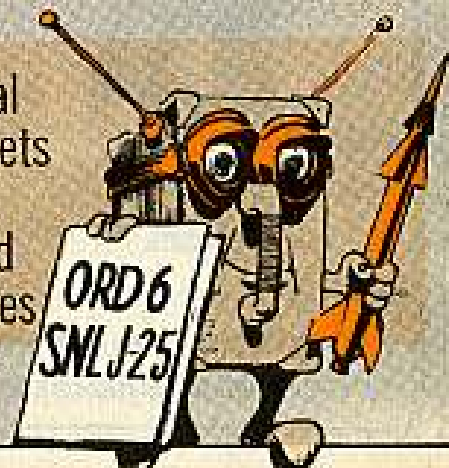



# Common Tools

You have organizational maintenance tool sets (composed of common tools found in Ord 6 SNL J-7 and Ord 3 SNL J-17). They're used by company, battalion, or regiment.

These sets are found in Ord 6 SNL J-7, under the sections shown below:

Sec. 1—No. 1 Common  
Ord Stock No.  
41-T-3538-850

**FSN 5180-754-0654**

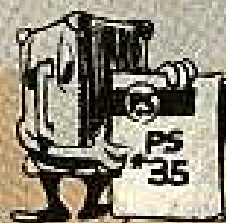

YOU'LL FIND 'EM  
IN P.S., TOO!

1 for each company, battery, or unit that does C motor vehicle service and has 8 to 75 vehicles. Supports 1 to 8 mechanics.

Sec. 2—No. 1 Supplemental  
Ord Stock No.  
41-T-3538-865

**FSN 5180-754-0653**



1 for each separate unit (such as separate company, separate battery) that does D service. (Should also have No. 1 Common.)

Sec. 3—No. 2 Common  
Ord Stock No.  
41-T-3538-855

**FSN 5180-754-0650**

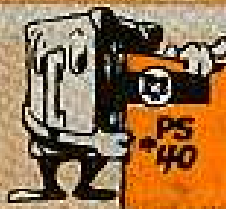

1 for each battalion or regimental maintenance platoon that has 76 to 350 wheeled vehicles and does D service.

Sec. 4—No. 2 Supplemental  
Ord Stock No.  
41-T-3538-870

**FSN 5180-754-0743**



1 for each battalion or regiment that does D service on track vehicles. (Should also have No. 2 Common.)

You'll find the rest of the sections listed in your Ord 1.

## MOS Tools

The MOS tool sets are basic hand tool sets that are normally authorized on the basis of one set for a particular MOS. These tool sets contain common hand tools that are required by the specialist to do his job. The MOS tool sets are found in Ord 6 SNL J-10.

## Special Tool Sets

Then you have special tool sets. You won't find these tools in your J-7 organizational maintenance tool sets, MOS tool sets, nor are they listed in your TOE. These tools are made especially for each particular model of vehicle and are needed to do second echelon maintenance. You'll find them listed in Section II of your Ord 7 SNL's for major items.

**Now turn the page and see the special tools for the M-series wheeled vehicles.**

# SPECIAL TOOLS

## FOR TACTICAL WHEELED VEHICLES

Special tools are something special—they're the tools made to do a specific job on a specific piece of equipment. To keep your trucks in top shape these tools are a must. They're shown in your TM's and listed in your Ord 7 SNL's.

Special tools come in sets—identified as

### SPECIAL SET A and SPECIAL SET B

Each piece of equipment needing special tools has its own A and B set... which means a Special Set A on a Jeep isn't the same as a Special Set A for a 5-ton truck.

All units that have mechanics should have either Special Set A or B (not both) for each type of automotive equipment.

These people rate the Special Set A:

One per lettered battery, company.

Headquarters of units above battalion level. (Units doing C service.)

Battalion headquarters, when battalion has a service company.

And here's how the Special Set B is divvied out:

One per battalion and regimental headquarters (except when battalion or regiment has a service company).

Service Company.

Numbered battery, company, similar headquarters doing maintenance work for other units. (Units doing D service.)

Now you know who gets them—here's what the special tools for the "M" series trucks look like:

TOOL SET, TRUCK, ¾-Ton, 4x4 (Dodge), M37, M42, M43, M56, and M152  
(TM 9-8030 and SNL G-741):

Tool Set (A) **FSN 5180-795-0200** **ORD 41-T-3568-455**

Tool Set (B) **FSN 5180-795-0223** **ORD 41-T-3569-455**



ADAPTER (steering gear  
idler arm shaft)

B-1



**FSN 5120-707-9783**

**ORD 41-A-18-241**

WRENCH (wheel bear-  
ing nut)

A-1

B-1

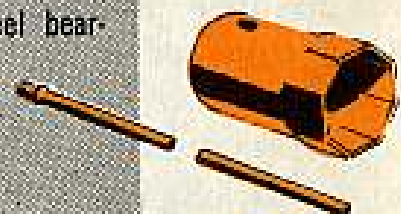

**FSN 5120-422-8972**

Key: A or B indicates which tool set item is in; this is followed by number showing quantity per set.

**TOOL SET, TRUCK, 1/4-Ton, 4x4, M38 (TM 9-8012 and SNL G740) M38A1, M170 (TM 9-8014, SNL G758) Willys MB, Ford GPW (TM 9-803, SNL G503):**

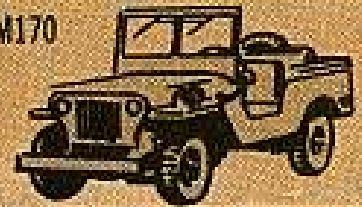

Tool Set (A) **FSN 5180-795-0305** **ORD 41-T-3568-442**

Tool Set (B) **FSN 5180-795-0306** **ORD 41-T-3569-442**

**ADAPTER, Puller**  
B-1

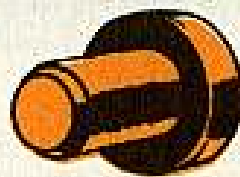

**FSN 5120-034-8460**

**COMPRESSOR** (shock absorber rubber grommet) (Models GPW and MB only)



A-1 B-1

**FSN 5120-473-6985**

**ORD 41-C-2554-400**

**PULLER** (water pump pulley)



B-1

**FSN 5120-795-0710**

**ORD 41-P-2908-240**

**PULLER** (remover & replacing rear spring bushing) (not required for Models GPW and MB)

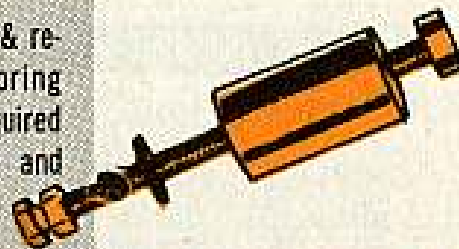

A-1 B-1

**FSN 5120-836-6660**

**ORD 41-P-2951-195**

**REMOVER & REPLACER** (front wheel outer bearing cup; used w/41-S-1047-330 Screw)

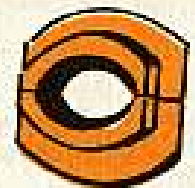

A-1 B-1

**FSN 5120-708-3346**

**ORD 41-R-2374-845**

**SCREW** (used w/remover and/or replacers)



A-1 B-1

**FSN 5120-708-3216**

**ORD 41-S-1047-330**

**WRENCH** (front axle wheel bearing nut)

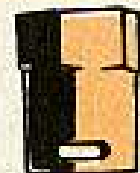

A-1 B-1

**FSN 5120-596-1370**

**ORD 41-W-3825-200**

**WRENCH** (brake adjusting)



A-1 B-1

**FSN 5120-708-0100**

**ORD 41-W-986**

**WRENCH** (engine: cylinder head bolt)



B-1

**FSN 5120-337-9134**

**TOOL SET, TRUCK, 2 1/2-Ton, 6x6, Reo and Studebaker M34, M35, M36, M44, M45, M46, M47, M48, M49, M50, M59, M60, M108, M109, M275, V17A, V18A, XM100, XM132 (TM 9-8022 and SNL G-742):**

Tool Kit (A) **FSN 5180-795-0351** **ORD 41-T-3568-503**

Tool Kit (B) **FSN 5180-795-0352** **ORD 41-T-3569-503**



**PULLER** (water pump pulley and fan hub)



B-1

**FSN 5120-708-3210**

**ORD 41-P-2958-78**

**SLING** (lifting cylinder head and manifold)



B-1

**FSN 5120-708-3213**

**ORD 41-S-3829-750**

WRENCH (ignition harness nut)

A-1 B-1

FSN 5120-795-0895

ORD 41-W-871-62



WRENCH (air compressor pulley nut)

A-1 B-1

FSN 5120-795-0404

ORD 41-W-1981-50



WRENCH (wheel bearing nut)

A-1 B-1

FSN 5120-795-0059

ORD 41-W-3825-62



REMOVER & REPLACER (wheel or rear spring bearing caps; used w/ 41-S-1047-330 screws)

B-1

FSN 5120-473-7372

ORD 41-R-2374-630



SCREW (remover and replacer bearing caps) threaded 1 1/4 NF-2 length 9"

B-1

FSN 5120-708-3216

ORD 41-S-1047-330



TOOL SET, TRUCK, 2 1/2-Ton, 6x6, (GMC) M135, M211, M215, M217, M220, M221, M222 (listed in TM 9-8024, SNL 6-749):

Tool Set (A) FSN 5180-795-0854

Tool Set (B) FSN 5180-795-0855



ADAPTER, hoist 2 hooked V-shaped w/ turnbuckle radiator and transmission lifting)

B-1

FSN 5120-092-9071



REMOVER & REPLACER, spring, 2 5/32" Dia., 1 3/4" Long, w/handle (brake shoe spring)

B-1

FSN 5120-795-0060

ORD 41-R-2375-20

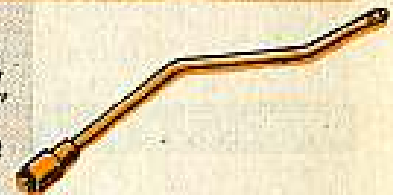

GAGE, lever with two 45° and one 90° offsets, 8 1/2" (Transmission: throttle valve lever)

A-1 B-1

FSN 4910-795-0168

ORD 41-G-214-475

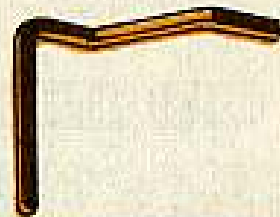

REPLACER, oil seal sleeve, 3 3/4" outside Dia., inside Dia. 3.280", 8 3/4" long (front and rear axle hub)

B-1

FSN 5120-795-0063

ORD 41-R-2395-518

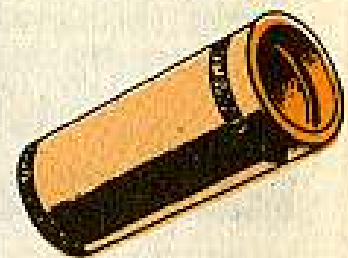

GAGE, PRESSURE, 300 lbs. maximum, w/coupling and hose (Transmission: check oil pressure)

A-1 B-1

FSN 6620-795-0330

ORD 45-G-1127-500

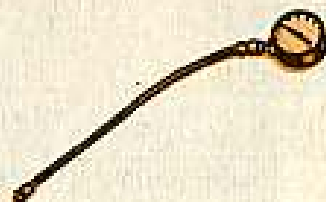

REPLACER, oil seal, 4.405" Dia., 5/8" wide w/handle (front and road wheel hub)

B-1

FSN 5120-795-0766

ORD 41-R-2392-635



SCALE, checking, 4 lbs. cap. w/hook, (steering wheel)

B-1



**FSN 5120-707-9178**

**ORD 41-S-503**

TOOL, bending, 3/4" thick, 1 7/8" wide, 3" long, (transmission: throttle valve lever)

A-1 B-1

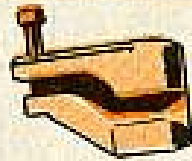

**FSN 5120-795-0171**

**ORD 41-T-3068-600**

WRENCH, wheel bearing nut, tubular, octagon, 3 7/16" opening 3/4" female square drive 5" long, w/2.115" Dia. tube pilot (front axle wheel bearing nut)

A-1 B-1

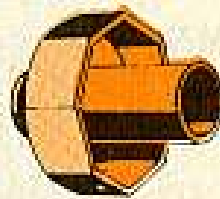

**FSN 5120-393-0560**

WRENCH, crowfoot, 3/4" opening, 3 5/16" offset handle, 10" long (ignition harness nut)

A-2 B-2



**FSN 5120-795-0895**

**ORD 41-W-871-62**

WRENCH, (cylinder head bolt used w/41-W-3631 wrench, torque)

A-1 B-1



**FSN 5120-473-6511**

**ORD 41-W-2964-700**

WRENCH, bearing adjusting nut, socket (detachable), octagon, 3 7/16" opening, 3/4" square drive, 1 7/8" long (rear spring seat trunnion)

A-1 B-1

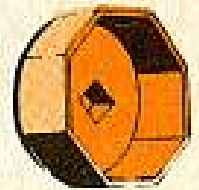

**FSN 5120-795-0946**

**ORD 41-W-545-5**

WRENCH, wheel bearing nut, tubular, octagon, 3 7/16" opening, 3/4" female square drive, 5" long with 1.795" Dia. tubular pilot (rear wheel bearing nut)

A-1 B-1

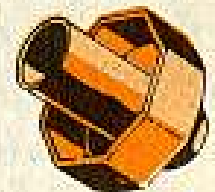

**FSN 5120-393-0561**

TOOL SET, TRUCK, 5-Ton, 6x6, M40, M41, M51, M52, M54, M61, M62, M63, M139, M246 (listed in TM 9-8028, SNL 6-744):

Tool Kit (A) **FSN 5180-313-3047** **ORD 41-T-3568-610**

Tool Kit (B) **FSN 5180-795-0827** **ORD 41-T-3569-610**



ADAPTER (steering wheel; used w/41-P-2954 puller)

B-1



**FSN 5120-303-1195**

WRENCH, (cylinder head bolt) (used w/torque wrench 41-W-3631)

A-1 B-1



**FSN 5120-473-6511**

**ORD 41-W-2964-700**

WRENCH, (wheel bearing nut)

A-1 B-1



**FSN 5120-378-3139**

**ORD 41-W-3825-72**

WRENCH (air compressor; belt tension adjusting)

A-1 B-1



**FSN 5120-390-7779**

# Connie Rodd's

"SHORT 'N SWEET DEPT"



Order by FSN

Canvas doors and side curtains for the M38 Jeep now have Federal stock numbers. Here they are:

ITEM	FSN	ORD STOCK NO.
① Curtain, door, left, assy	2540-769-7413	G740-7697413
② Curtain, door, right, assy	2540-769-7414	G740-7697414
③ Curtain, side quarter, left	2540-769-7415	G740-7697415
④ Curtain, side quarter, right	2540-769-7416	G740-7697416

The canvas for your M38A1's are now ready to go. They stack up this way —

ITEM	FSN
① Curtain, door, left, assy	2540-699-7035
② Curtain, door, right, assy	2540-699-7032
③ Curtain, side quarter, left	2540-699-7033
④ Curtain, side quarter, right	2540-699-7034

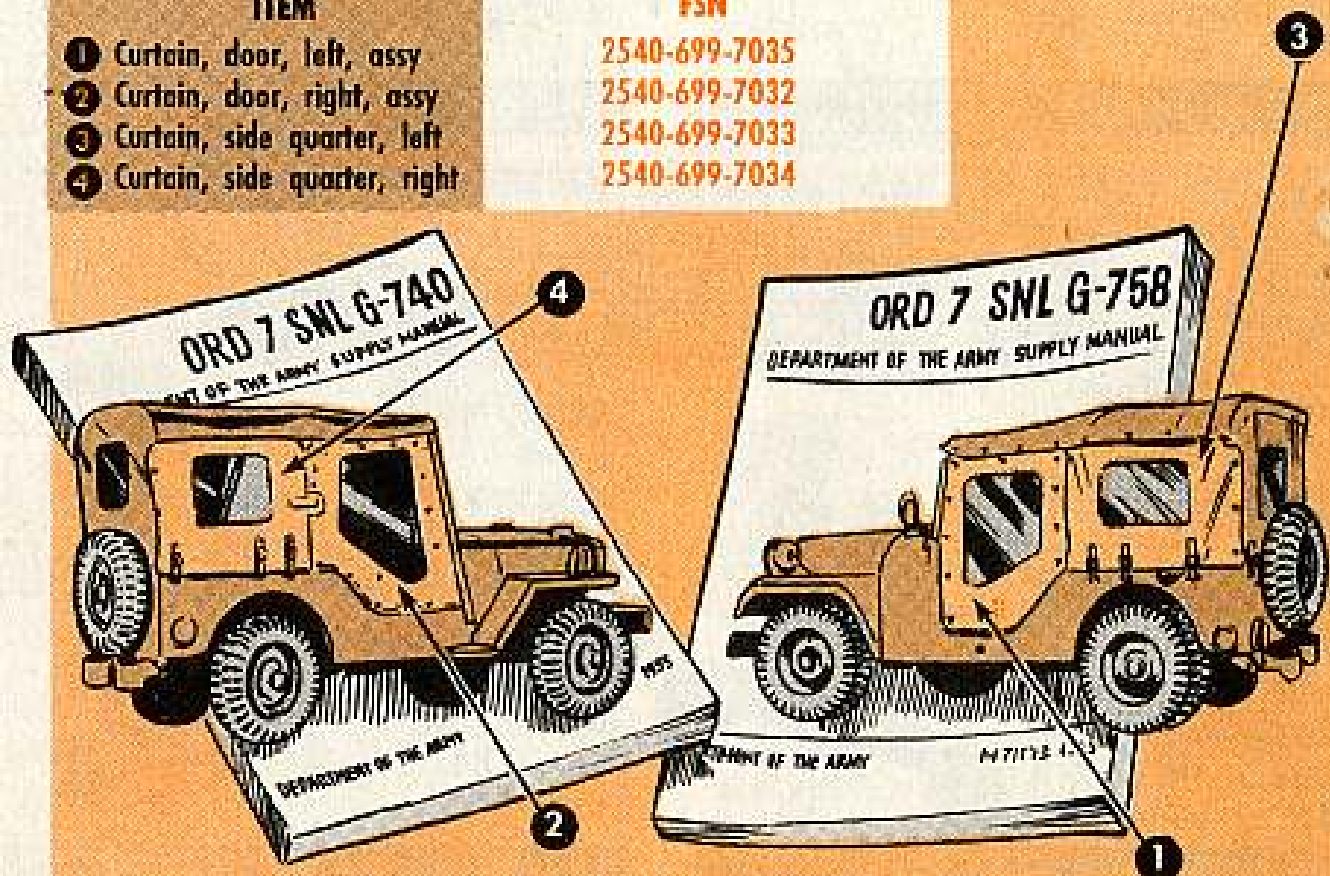

## Tilt!

There's good news for sober outfits with tipsy 1½-ton, 2-wheel trailers that are being used to carry mounted equipment. Some new medicine that's just hit the market has instructions for putting a good sturdy rear support leg on your M104, M104A1, M105A1 and M105A2 trailers.

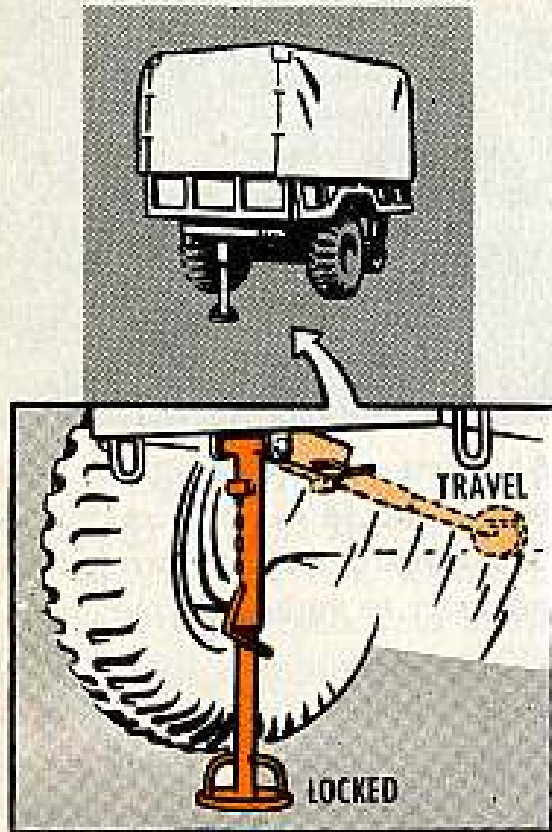

This new prescription goes by the name of MWO Ord G754-W11 (20 Mar 57). If your trailers have bum legs — or don't have a leg to stand on — just mention this cure-all MWO the next time those trailers go to Ordnance for a maintenance visit.

## That does the trick

Nope, it's not just a rumor. The truth is that the eye bolts which hold up the spare tire on those Model 424 2½-ton stake and platform jobs are

breaking off near the eye — because some operators aren't mounting the spare just right.

When mounting the tire, make sure you get it centered properly. Just to be sure it's all the way into its mounting frame, give it a coupla good kicks with the bottom part of your size 12's before buttoning it up. If there's even the slightest movement in that tire after you batten it down, it'll loosen even more and a flexing motion (back and forth) will be set up. Then, that eye bolt'll start to shear off.

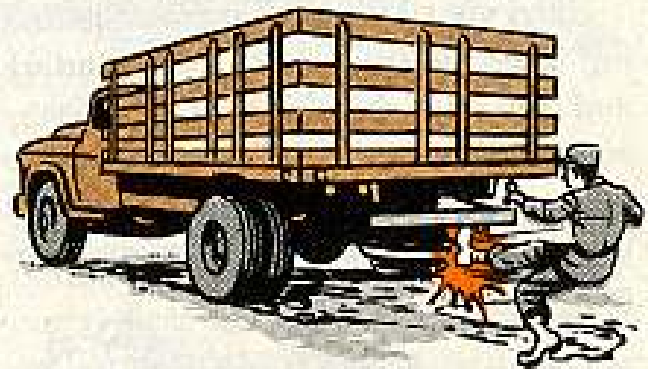

Remember: Kick it into its stall good 'n hard and keep the play out of it. Now, you'll have your spare when you get to the end of your run.

## Water bugs

When items like tank ballistic computers and azimuth indicators get bugs in them, a good, fast gun-lay is next to impossible, and first-round hits are a bad joke.

One of the quickest ways to foul up those precision instruments is to haul a water or steam jenny hose into your tank turret to clean the place out.

No matter how careful you are, that pressurized water or steam will go where it's not supposed to — and a clean

tank won't do you a bit of good with its instruments loused up.



Remember, friend, use still water, rags, brushes, and tender care only — just like you'd wash the inside of your car, and keep those covers on the azimuth indicators when they're not in use.

### *Jaw breakers*

Keep your M48 tank's starter grinding after the engine's already running and you may hear a strange noise — starter jaws grinding themselves to pieces. Same thing can happen if you hit the starter switch while your engine's rotating to a stop.

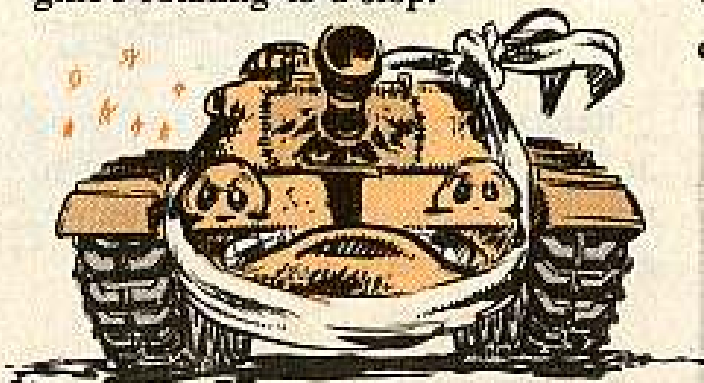

To save your vehicle a deadline — press the starter switch until the engine starts, but no longer than 30 seconds. If the engine doesn't take right off within 30 seconds — lay off the starter and let her cool from three to five minutes before you try again.

It'd be smart to allow this cooling off period after every starting try of 30 seconds, just like it says in para 34 of TM 9-7012 (Aug 54).

### *Torque wrench*

One tool you should have in your Second Echelon Tool Kit No. 1 Common is:

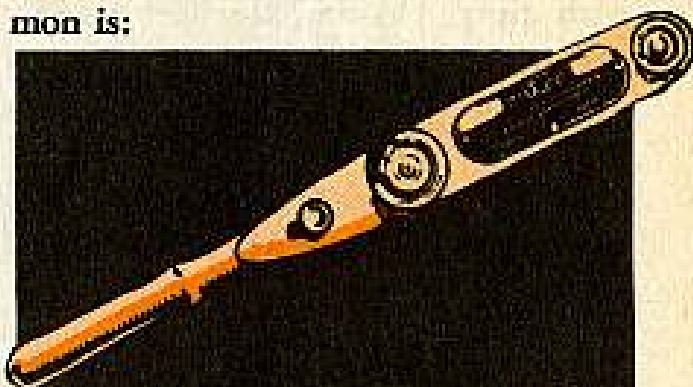

WRENCH, TORQUE, rigid frame, L-hdl, w/rte adpt dial indicating mech  $\frac{1}{2}$ " sq drive, male, 175 ft lb rated (Ord Stock No. 41-W-3631; FSN 5120-242-3262).

You're now authorized to have it so why not hop down to supply and put your order in.

And you men working on M242, M243 and M244 van trailers equipped with magnesium wheels can get your commander to authorize your having:

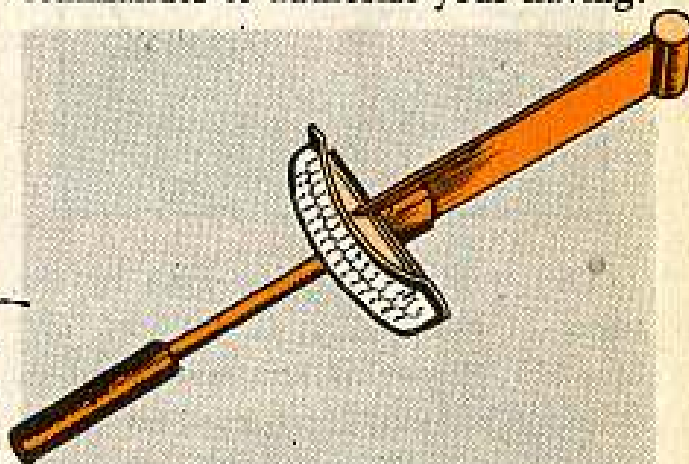

WRENCH, TORQUE, deflecting frame, L-hdl, pl indicating torque mech w/visual indicating mech  $\frac{3}{4}$ " sq male drive, 0 to 300 ft lb rated cap (Ord Stock No. 41-W-3634; FSN 5120-230-6383).

If you get this tool, you can include it in your Second Echelon Tool Kit No. 1 Common along with the 175 ft lb cap wrench.



## Rick-a-ratch

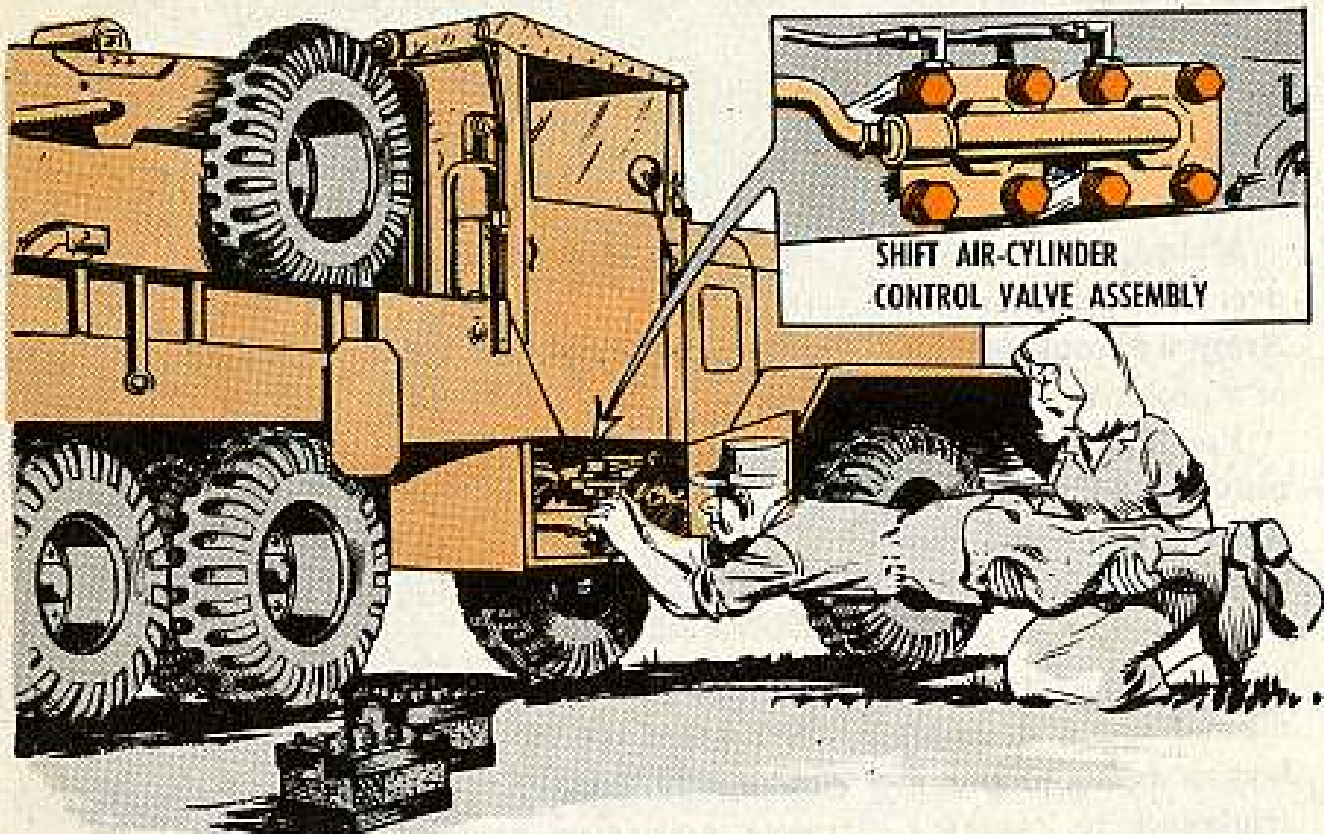

Those cap screws holding the shift air-cylinder control-valve assembly in place on your M62 5-ton wrecker may be loosening up without your knowing about it. That control-valve assembly's found on the shifter housing — to the right rear of the bottom of the shifting lever.

It looks like an awfully rough place to get at, so a lot of time nothing's been done to tighten those screws down. But now, here's the dope on how to get to those cap screws and what tool to use to tighten 'em.

The tool you'll need is a 7/16-inch socket with an extension and a ratchet handle. You'll find this stuff in your General Mechanics Tool Set.

Now, to get at that air-cylinder control-valve assembly, open the battery-box door on the right side of the wrecker. It'd be a good idea to either

unhook your batteries' negative and positive cables or to take the batteries outta there altogether — so you won't get any arcing if the ratchet hits the battery.

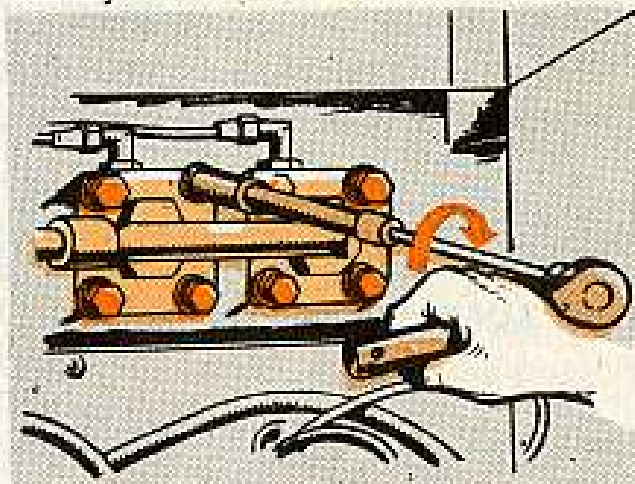

USE A 7/16-IN SOCKET WITH AN EXTENSION AND A RATCHET HANDLE

Once you open that door, there's that air-cylinder control-valve assembly in full view. All you gotta do is reach in there with your wrench and tighten.



# LUBING YOUR MODEL 424 (Stake and Platform) 2½-TON GMC TRUCK

Making the change-over from civilian to the Army-way could be a bit of a problem.

You Model 424, 2½-ton GMC stake and platform drivers and mechanics may have taken a look at the lube order in the manufacturer's manual and said—huh? Lots of foreign-looking symbols there, 'cause it's civilian lingo.

Here's the lube guide translated into military symbols. Now you can be on home ground with GAA, OE, HB, GO and OHC by using this chart when lubing your 424.

	LUBRICANT	INTERVAL
SPRING SHACKLES AND BRACKETS	GAA	1
GENERATOR	OE	1
STEERING DRAG LINK	GAA	1
WHEEL BEARINGS	GAA (Amm 2 or 3)	12
STEERING KNUCKLES	GAA	1
TIE ROD ENDS	GAA	1
CARBURETOR AIR CLEANER	OE	1
GOVERNOR AIR FILTER	OE	1
STEERING DRAG LINK	GAA	1
STEERING GEAR HOUSING	GO	1
CLUTCH PEDAL SHAFT	GAA	1
SPRING SHACKLES AND BRACKETS	GAA	1
BRAKE PEDAL	GAA	1
BRAKE MASTER CYLINDER	HB	1
SPEEDOMETER ADAPTER	GAA	1
PROP SHAFT U-JOINT	GAA	1
SPRING SHACKLES AND BRACKETS	GAA	1
WHEEL BEARINGS	GAA (Amm 2 or 3)	12
REAR AXLE	GO	1
SPRING SHACKLES AND BRACKETS	GAA	1

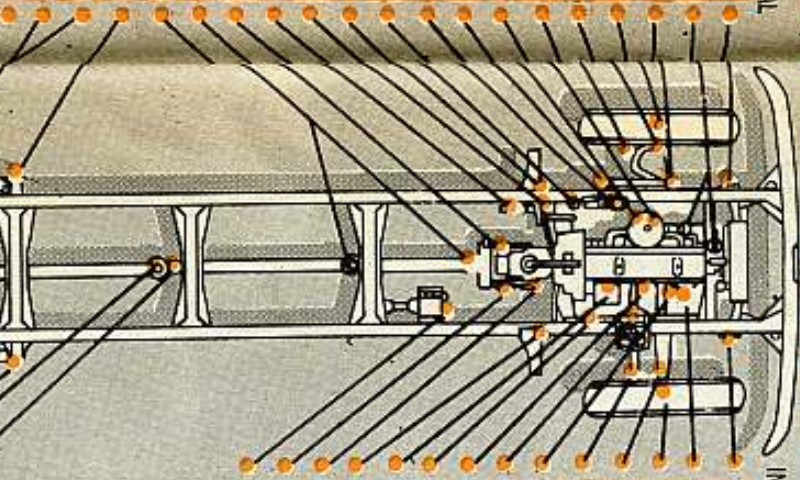

	INTERVAL	LUBRICANT	
SPRING SHACKLES AND BRACKETS	1	GAA	
ENGINE OIL FILTER	6		
WHEEL BEARINGS	12	GAA (Amm 2 or 3)	
STEERING KNUCKLES	1	GAA	
TIE ROD ENDS	1	GAA	
CRANKCASE	6	OE	
BATTERY TERMINALS	1	GAA	
DISTRIBUTOR	1	GAA	
HYDROVAC AIR CLEANER	1	OE	
STARTER	1	OE	
SPRING SHACKLES AND BRACKETS	1	GAA	
TRANSMISSION	1	GO	
CONTROL LINKAGE	1	OE	
HYDROVAC	12	OHC	



LEARN TO HEAR YOU TALK IN "CIVILIAN"!



LUBRICANTS	TEMPERATURES
OE—OIL, LUBRICANT, ENGINE	ABOVE +32°F to +40°F to 0°F to
GO—LUBRICANT, GEAR UNIVERSAL	+32°F to -10°F to -55°F
HB—FLUID, HYDRAULIC BRAKE	
GAA—GREASE, AUTOMOTIVE & ARTILLERY	
OHC—HYDRAULIC, OIL, PRESERVATIVE	

INTERVALS
(for tactical units)
D—Daily
W—Weekly
1—1,000 miles
6—6,000 miles
12—12,000 miles

PROP SHAFT SLIP JOINT	1	GAA	
PROP SHAFT U-JOINT	1	GAA	
SPRING SHACKLES AND BRACKETS	1	GAA	
WHEEL BEARINGS	12	GAA (Amm 2 or 3)	
PROP SHAFT U-JOINT	1	GAA	
SPRING SHACKLES AND BRACKETS	1	GAA	



Here're some added tips you'll need to know when lubing your Model 424. The items that need lube are listed in alphabetical order, so when you go to grease an item, all you have to do is check this list and, together with the lube chart, you'll be able to get the full dope:

THIS IS ALSO  
"CIVILIANESE"



1. Battery Terminals—Keep coated
2. Brake Master Cylinder—Check level (must be at least  $\frac{3}{4}$  full)
3. Brake Pedal—One grease fitting
4. Carburetor Air Cleaner—Clean and refill
5. Clutch Pedal Shaft—One grease fitting
6. Control Linkage—Use oil can or spray
7. Crankcase—Check daily—keep to "Full" mark
8. Distributor—Grease through grease cup. Use one drop of OE10 on the breaker pivot; and a thin smear of petroleum jelly on the breaker cam.
9. Engine Oil Filter—Replaceable-element type
10. Generator—Oil through two oil cups
11. Governor Air Filter—Clean and reoil
12. Hydrovac—Fill to plug level
13. Hydrovac Air Cleaner—Clean and reoil
14. Prop Shaft Slip Joint—One fitting per joint
15. Prop Shaft U-Joint—One fitting per joint
16. Rear Axle—Fill to plug level; drain and refill every 12,000 miles
17. Shock Absorbers—No messing with these—they're the non-refillable type
18. Speedometer Adapter—One fitting
19. Spring Shackles & Brackets—Six fittings each side
20. Starter—Grease through cup on commutator end; grease drive end every 12,000 miles
21. Steering Drag Link—One fitting each end
22. Steering Gear Housing—Fill to plug level
23. Steering Knuckles—Two fittings each side
24. Tie Rod Ends—One fitting each end
25. Transmission—Fill to plug level; drain and refill every 12,000 miles
26. Wheel Bearings—Remove and clean; then grease by hand or lubricator, using GAA Amendment 2 or Amendment 3 only

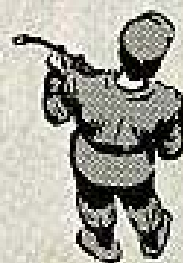

# JOE'S DOPE

There's no magic trick to making your juice box (battery) do its job!

The night swirled about the lone figure struggling up the hill against the clawing wind . . .



... The wind . . . it was the wind whispering its metaphysical secrets that seemed to betray the ghosts that were abroad this night.

... But the man . . . climbing ant-like up the craggy side of the hill . . . at last reached a secret door on the hilltop . . .

... He opened the door and stepped into a laboratory lit by a single candle.



JOE!! ... IT'S ABOUT TIME... THIS WAY, PLEASE...

WHERE IS IT?



HERE... AND HURRY!

HMMM... NO WONDER... IT'S A MESS... THE MOST IMPORTANT THING ABOUT BATTERY MAINTENANCE IS TO KEEP 'EM CLEAN ... ALWAYS AND EVERYWHERE!



SOME ELECTROLYTE WILL COLLECT ON THE OUTSIDE LEAVING ACID SALTS WHEN IT DRIES. THOSE SALTS ATTRACT MOISTURE FROM THE AIR, AND...

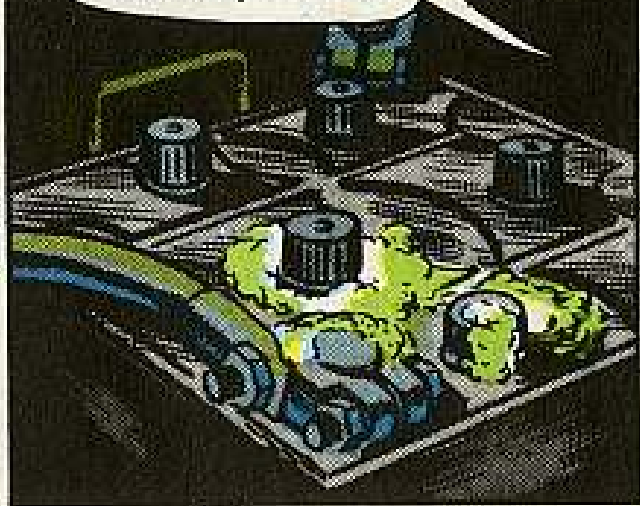

...WHEN MOIST, THE SALTS CONDUCT CURRENT LIKE CRAZY. YOUR BEST DEFENSE IS TO KEEP YOUR BATTERIES CLEAN.

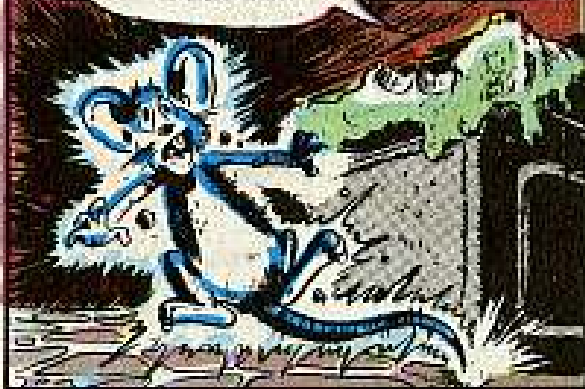

PLEASE STEP OUTSIDE SIR...



WASH YOUR BATTERIES REGULARLY AND AT EVERY "C" SERVICE PULL 'EM OUT AND CLEAN 'EM AND THEIR CARRIERS.



HERE'S A GOOD WAY TO DO IT... MAKE A SOLUTION OF ABOUT A POUND OF BAKING SODA PLUS TWO GALLONS OF WATER.



Sodium Bicarbonate, technical, 1 lb. - 6810-264-6618, 100 lb. - 6810-297-0092. (Chemical)

CAREFUL... DON'T GET ANY OF THE SOLUTION DOWN INSIDE THE BATTERIES... USE THE SODA MIX UNTIL IT STOPS FOAMING... THEN RINSE WITH LOTS OF CLEAN WATER.



WHEN THE CARRIER IS DRY... TOUCH UP BARE SPOTS WITH ACID-RESISTING PAINT (ORDINARY BLACK PAINT IF YOU CAN'T GET ANYTHING ELSE...)



... AND WHILE YOU HAVE THE BATTERIES OUT FOR THE "C" INSPECTION, CLEAN UP THE TERMINAL POSTS AND CABLE CLAMPS... YOUR COPPER CABLE LEADS AND STEEL CLAMPS WILL CORRODE QUICKER THAN THE LEAD TERMINAL POSTS, SO GIVE 'EM SPECIAL ATTENTION **GREASE 'EM!!**

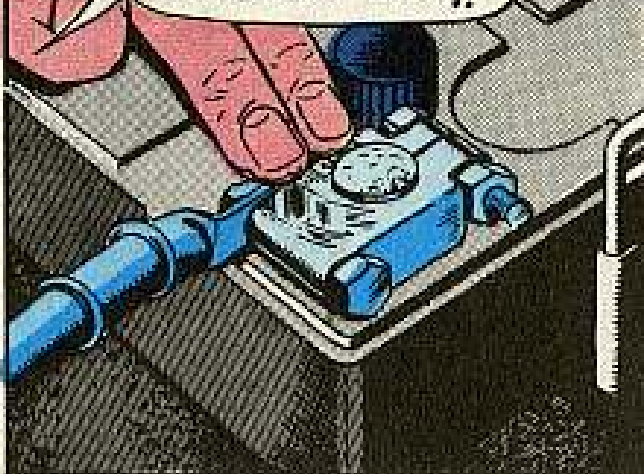

... Remember... on your "B" service check electrolyte level and add water if needed. On your "C" service pull 'em and clean 'em... and on your "D" service don't fail to brighten up the posts and clamps.

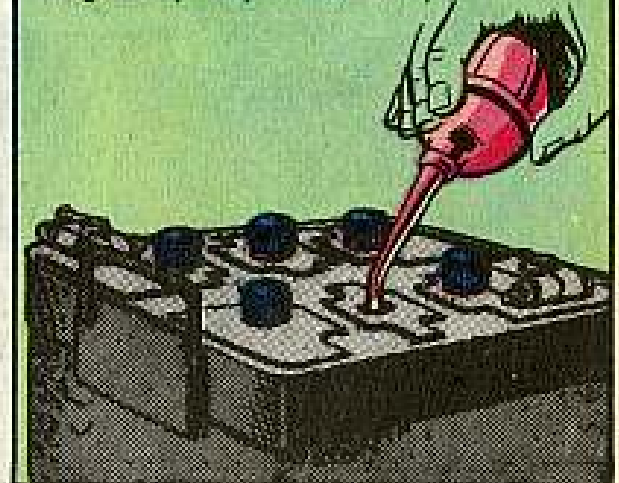

... AND **KEEP 'EM FILLED...**  
 AN EMPTY BATTERY IS WORSE THAN A DIRTY ONE, WHEN IT'S RUN LOW ON WATER. THE ACTIVE MATERIAL ON THE PLATES DRIES OUT AND GETS SO HARD THAT IT CAN'T FUNCTION WHEN THE BATTERY FINALLY IS FILLED... THEN YOU'VE HAD IT...

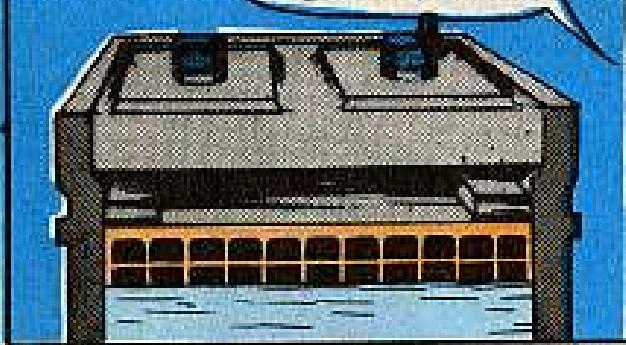

... MATTER OF FACT **OVERFILLING** IS JUST AS BAD... IT'LL MESS UP YOUR BATTERY AND BATTERY BOX AND CREATE CORROSION ON ALL METAL PARTS, SO FILL YOUR BATTERY WITH **CARE**



HMM... I DON'T HAVE ANY DISTILLED WATER HANDY!

WELL, TRY TO GET THE DISTILLED WATER - IT'S PREFERRED. IF YOU REALLY CAN'T GET IT, THEN USE DRINKING WATER - IT'S BETTER THAN NO WATER AT ALL.



OUT IN THE FIELD UNDER ROUGH CONDITIONS, I'VE KNOWN GUYS TO CATCH RAINWATER IN A CLEAN TARP, HELMET, JAR OR BARREL... CUTE IDEA BUT TRICKY...



... IF YOU HAVE TO DO THIS, MAKE SURE THE WATER IS ALLOWED TO SETTLE UNTIL IT'S CLEAR....



... AS FOR **TAPWATER** LET IT RUN AWHILE SO'S YOU DON'T PICK UP MINERALS FROM THE PIPE... AH - WHILE IT'S RUNNING I'LL JUST TACK UP THIS PIN-UP!



# Joe's Dope Sheet

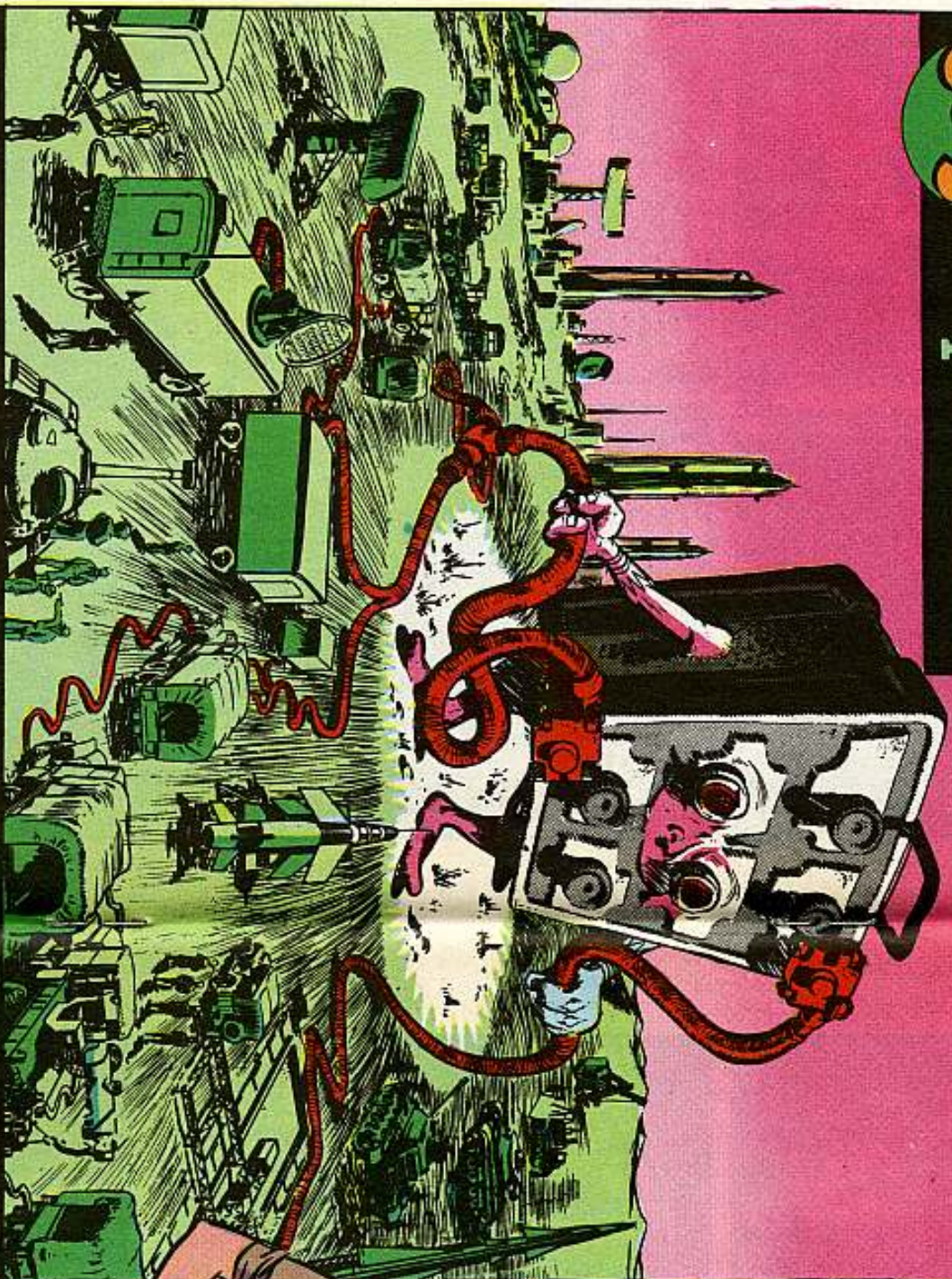

From the jeep to the NIKE and DART,  
That ol' battery's in at the start;  
So you see what we mean,  
When we say "Keep 'em clean,"  
And **maintain** the defense  
machine's "heart."

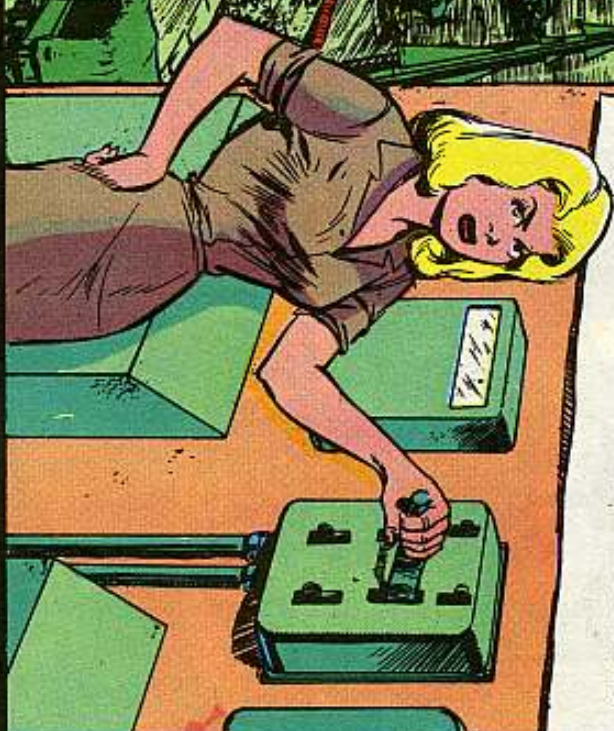

WE HAVE THE WORLD'S BEST EQUIPMENT... *Take care of it*

NOW, SIR, LET'S GET INTO ANOTHER PROBLEM...**FAILING TO KEEP 'EM CHARGED...** IN THE TRUCK OR OUT.



IN THE TRUCK: SIMPLY CHECK WITH YOUR HYDROMETER EVERY "B" INSPECTION. IF YOUR BATTERY'S BELOW 1.225 (AFTER YOU ADJUST FOR TEMPERATURE) GET A CHECK ON YOUR CHARGING SYSTEM.



IF A VOLTMETER DOESN'T SHOW 25 TO 27.5 VOLTS (WITH THE ENGINE RUNNING)...**BETTER HAVE THE SHOP BOYS FIND OUT WHY.**

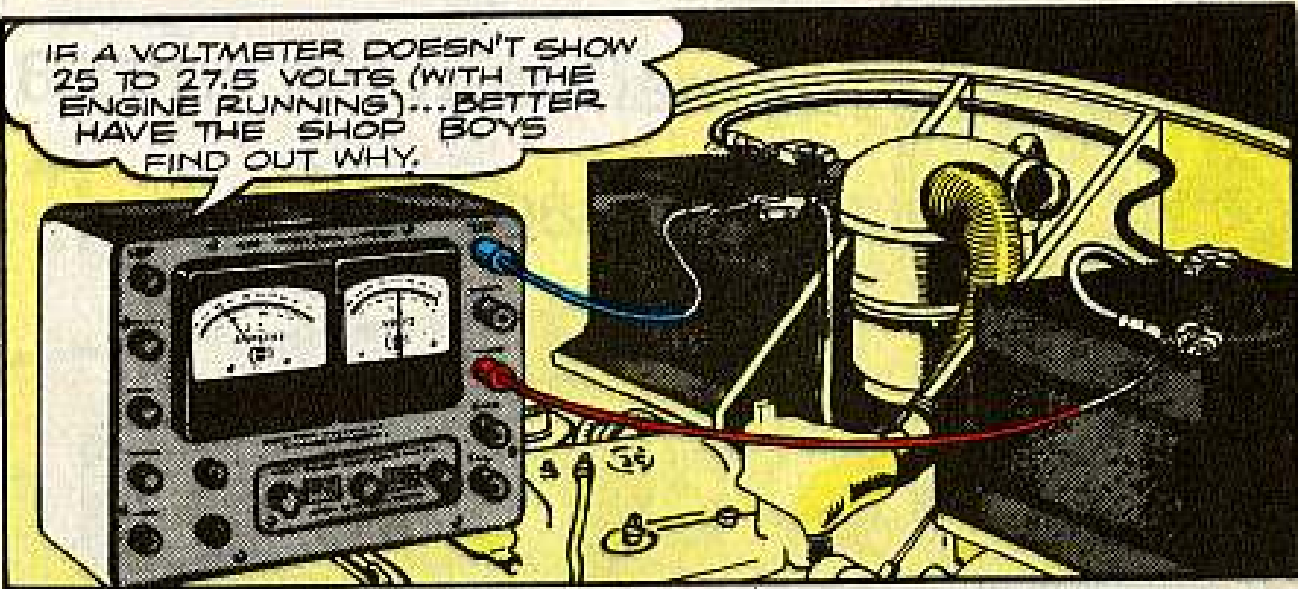

SEE IF YOU'RE GETTING PLENTY OF GENERATOR OUTPUT. MAYBE YOU'RE NOT RUNNING THE TRUCK ENOUGH TO KEEP THE BATTERIES UP...**SO SEND 'EM TO THE SHOP FOR RE-CHARGING.**



NOW ABOUT **WINTER...** YOU GOTTA DOUBLE THE CHECKING... ONLY YOU RECHARGE BELOW 1.265 (LIKE TM 9-2855 SAYS)... A LOW BATTERY'LL FREEZE QUICKER THAN A CHARGED ONE...**THE ONLY ANTI-FREEZE FOR BATTERIES IS TO KEEP 'EM WELL CHARGED.**







BE SMART  
ABOUT ADDING  
WATER IN  
COLD WEATHER!



ADD WATER JUST  
BEFORE TRUCKS GO  
ON A LONG RUN.  
IDEA IS TO KEEP  
THE WATER AND  
ELECTROLYTE WELL  
MIXED---TO PREVENT  
FREEZING.



ANOTHER THING...HAPPENS  
Y'RUN A BATTERY DOWN IN  
AN **UNSUCCESSFUL** TRY  
AT STARTING A TRUCK ON A  
COLD DAY PUT IT IN A WARM  
SPOT 'TILL YOU GET THE BATTERY  
RECHARGED, OR THE TRUCK  
RUNNING BY OTHER BATTERIES.  
THEN REINSTALL 'EM.



NOW ABOUT **STORAGE**...  
OUT OF THE TRUCK... **LIKE  
IN STORAGE**, KEEP AN  
EYE ON 'EM. WHEN THEY  
FALL BELOW 1.225,  
RECHARGE 'EM.



STORAGE IS AN ART AND  
A SCIENCE... SO DON'T GO  
FOR THE SUPERSTITION  
ABOUT CONCRETE SUCKING  
THE CHARGE OUTTA  
'EM. CONCRETE WON'T  
EFFECT 'EM EITHER  
WAY.



LIKE I SAID EARLIER,  
ELECTROLYTE CREEPS  
LIKE CRAZY... SPREADS  
ACROSS THE TOP OF  
THE BATTERY AND  
STARTS CONDUCTING  
CURRENT TWIXT THE  
TERMINALS!

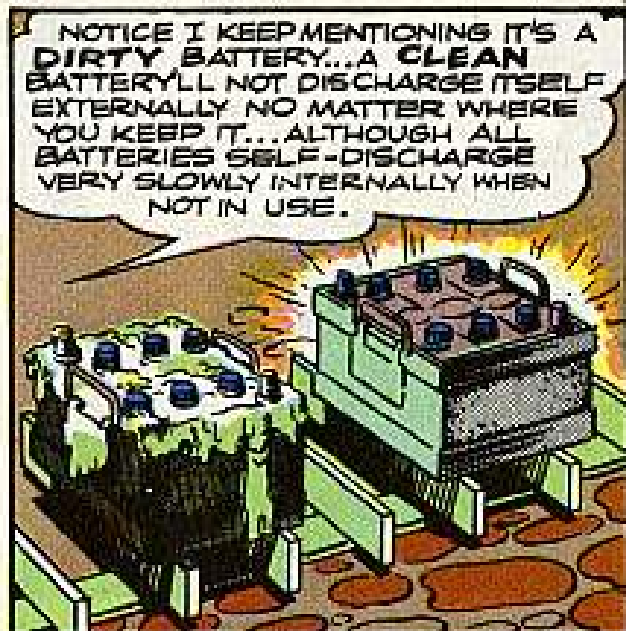

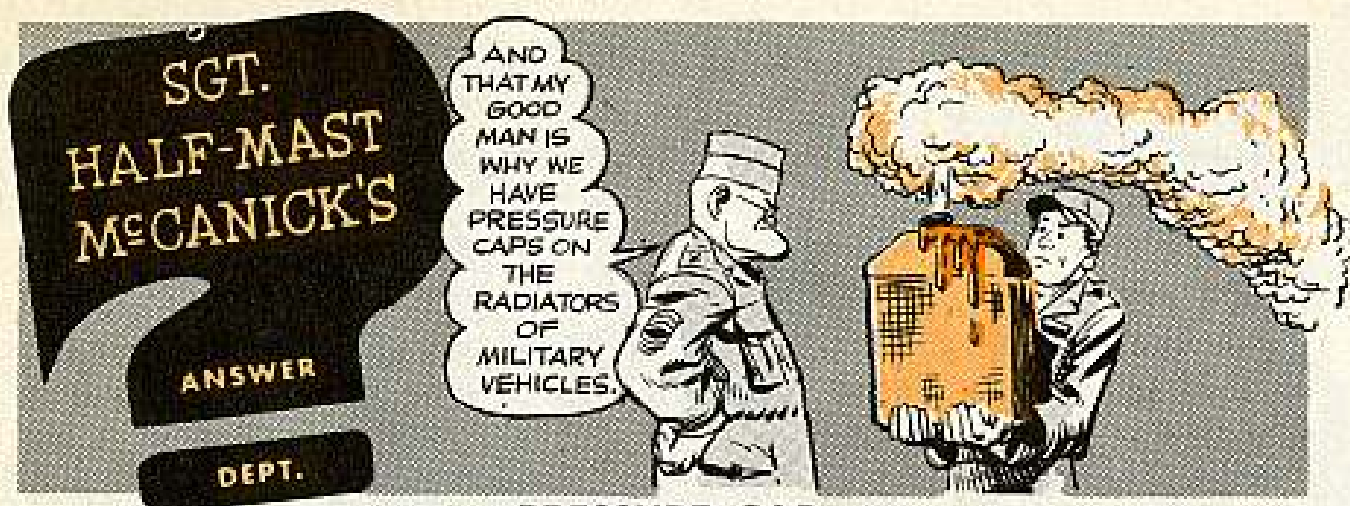

## PRESSURE CAP

Dear Half-Mast,

*What's the purpose of the pressure caps on the radiators of military vehicles?*

Lt W. V. N.

Dear Lt W. V. N.,

The pressure radiator cap is used to reduce evaporation in the cooling system, prevent boiling at high altitudes, and allow the cooling system to operate at higher temperatures without boiling or coolant overflow, when on severe climbs or hard pulls. Water under pressure can go to higher temperatures before it boils.

*Half-Mast*

## QUADRANT QUERY

Dear Half-Mast,

*Why isn't there an elevation quadrant on the M41A1 tank's 76-mm gun?*

SFC R. L. H.

Dear SFC R. L. H.,

Consider the flat trajectory and high velocity of your gun, plus the size and burst characteristics of your 76-mm rounds. Then, add the normal tactical employment of your light tank—screening and reconnaissance—and you have your answer.

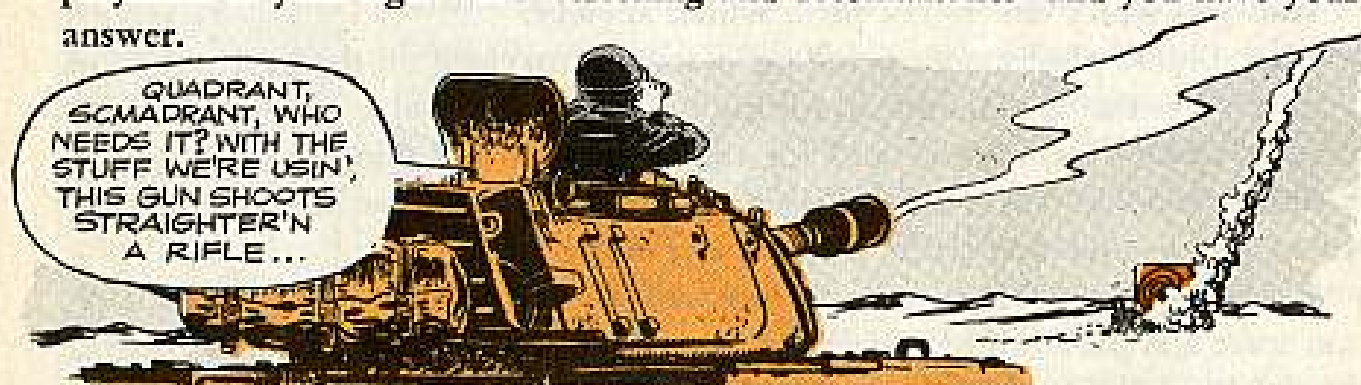

Except in an unusual situation, those guns wouldn't be used for indirect fire. If it should happen that you did get an indirect fire mission, the OVM of the tank gives you an M1 gunner's quadrant (that triangular, portable job), which will do a good job of laying for indirect fire.

*Half-Mast*

## GAS RIGHT

Dear Half-Mast,

*Can I use standard 88-octane gas in my tank engines, or must I use 80-octane aircraft gas?*

Capt J. J. G.

Dear Capt J. J. G.,

You can use any gasoline (80 octane-motor method, 86 octane-research method) which meets Federal Specification VV-M-561a (that's all issue gas) in your tank engines and be all right as far as detonation is concerned.

When your vehicles are to be stored for any length of time, it's best to use aviation gasoline in processing 'em. This is because the avgas has less tendency to gum up the fuel systems when standing idle. But as long as your vehicles are getting regular use, the standard issue vehicle fuel is OK.

Half-Mast

## GUESS YOUR WEIGHT

Dear Half-Mast,

*On these Model 424 2½-ton stake and platform trucks, the nomenclature plates list the maximum payload for that truck as 14,000 plus pounds.*

*I'll be hanged if I'm going to load 14,000 pounds on that truck and ride it over the rough terrain we have around here. Tell me, Sarge, just what is the cross-country load for that truck? Can't find it anywhere.*

SP2 J. J. P.



Dear SP2 J. J. P.,

And you won't either—not for a while, anyway.

That 14,000 plus pounds given for maximum payload on the name plates of your truck is the maximum load for highway operation only. As there isn't any dope as to the cross-country load for that truck, the best thing to do is look at a similar truck in TM 9-2800-1 (Feb 53), "Military Vehicles," and get a cross-country figure for that truck. Then, use it on the 424.

For example, this TM lists the off-highway payload for the Model K7 IHC 2½-ton stake and platform truck as 5,000 pounds. The same figure is given for the Model L172 IHC 2½-ton stake and platform.

So, drawing conclusions, it looks as if that 5,000 figure'd be a safe one to use when loading your 424 for a trip across yonder. Of course, that 5,000 pounds agrees with the 2½-ton description of the truck.

Half-Mast

## GOOEY GOING GULPS GAS

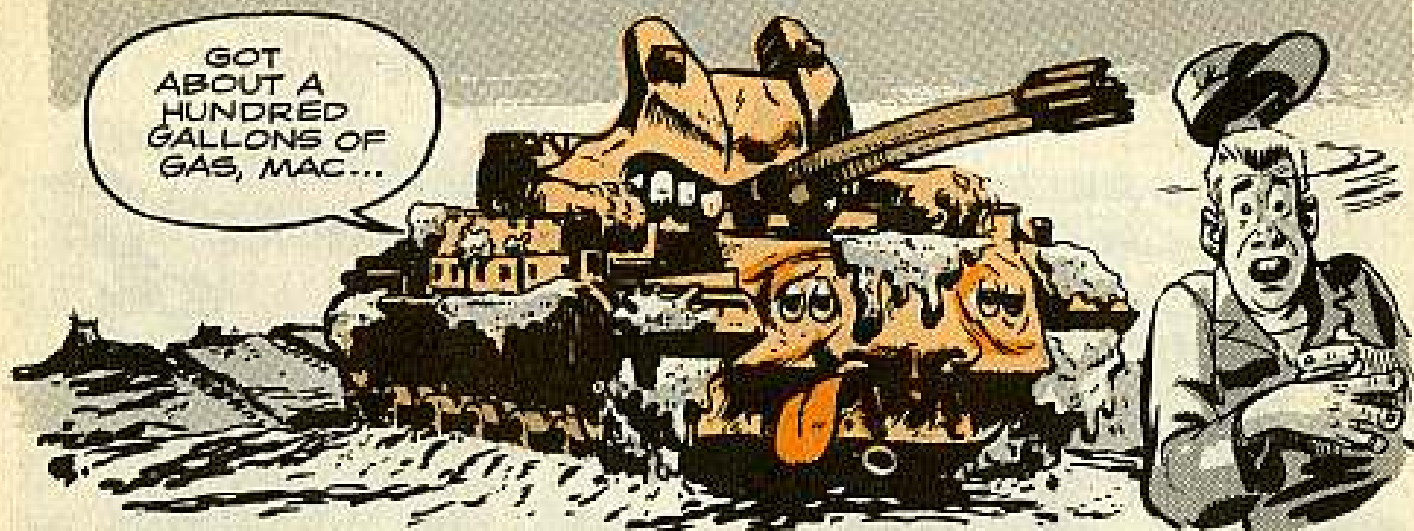

Dear Half-Mast,

How come my M42 "Dusters" and other vehicles, use so much more gas when operating in the mud? Gasoline consumption is as much as 50 per cent higher. Can't all be slippage, can it?

Lt A. C. B. Jr.

Dear Lt A. C. B.,

You're right, the gasoline consumption of your "Duster" or any other vehicle will go up when operating on muddy ground.

Slippage accounts for a good deal of this, particularly on you slick Texas Gumbo, or the Kentucky clay. But there's another factor, too. Since mud is harder to get through than dry ground, you use more throttle, and so more gasoline. Also, your torque-converter transmissions allow more engine revolutions per output shaft revolution in heavy going, and once more you use more gasoline. Or if you are operating a wheeled vehicle, either you shift a manual transmission down to a lower gear, or your Hydra-Matic shifts itself down. Either way, you are using more engine revs for less miles forward.

You see, it can require up to five times as much horsepower to move a vehicle in gumbo mud as it does to move the same vehicle on good roads. So, up goes the fuel bill.

None of this does any harm to the vehicle, as long as you drive it right, but you've gotta remember to provide the extra gas. You don't want the battalion to run out way off in the hills.

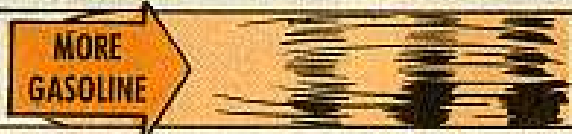

Half-Mast

DID YOU SEE A FELLOW 'ROUND  
HERE FUZIN' SOME SHELLS?.. HE  
CALLED A FEW MINUTES AGO  
FOR SOME ADVICE!



## TAKING THE CONFUSION OUT OF FUZIN' WITH **THE M26 FUZE SETTER**

There hasn't been too much said about the M26 fuze setter and maybe you have some questions about it. So, pull up an empty ammo box and lend an ear.

You're now looking at the M26 as it appears when you raise the lid on its M66 carrying case.



And this is how the fuze setter looks when you take it out of the case and raise the handle. The handle, by the way, folds flat in either direction.



## HERE'S A SPECIAL FEATURE OF THE M26

Take the cap from one end of the handle and slip in two BA-42 batteries.

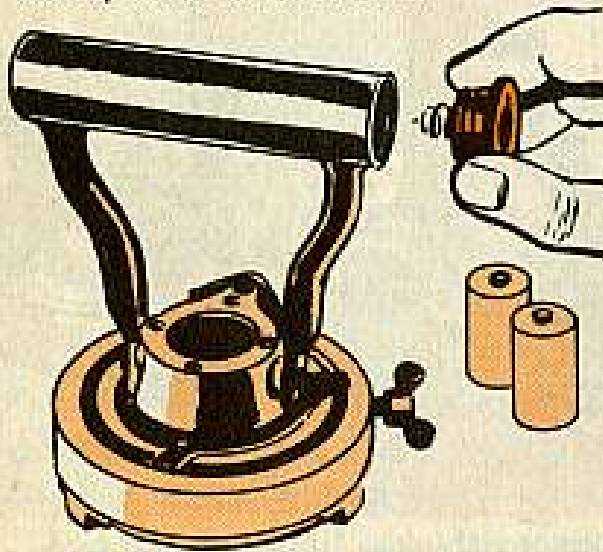

Replace the cap and you're in business.

When darkness hits your area:  
Push the button on the other end of the handle...

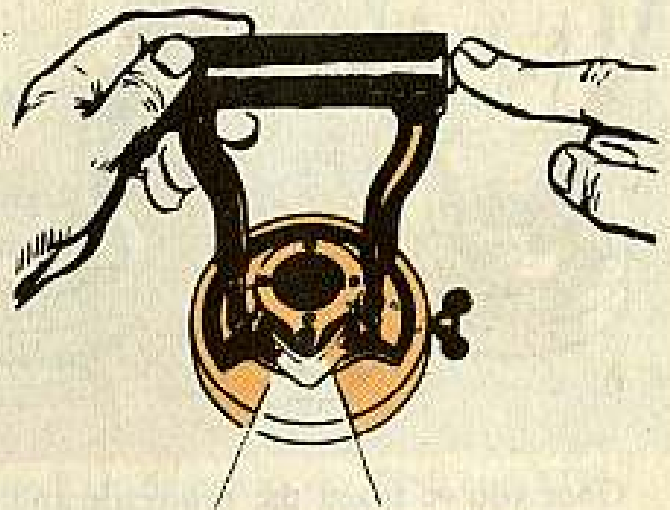

...and light comes out here.

The light makes it a snap to read the time scale. Incidentally...to get light, you've got to keep the handle upright.

There's another thing which makes the M26 a standout—it has two time scales.

The outer scale runs from 0 to 75 seconds and each second is divided into  $\frac{2}{10}$  second.

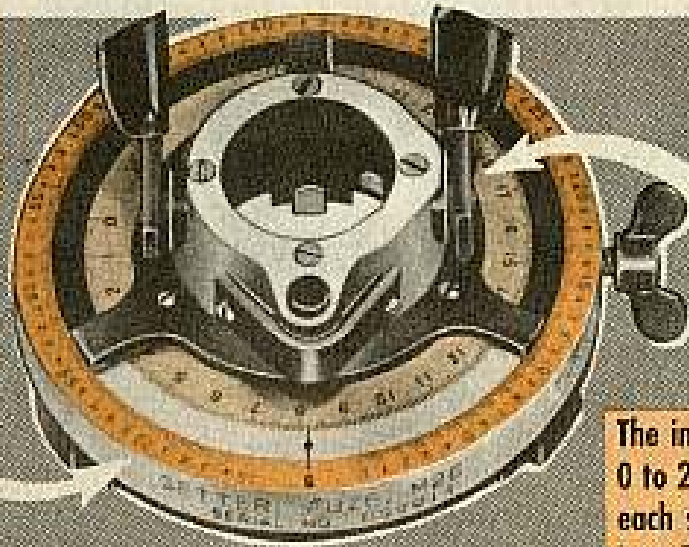

The inner scale runs from 0 to 25 seconds and each second is broken into  $\frac{1}{10}$  second.

You can use the M26 to set these fuzes: M500, M501, M54, M55 series and M67 series.

The M26 is operated the same as the M22 and M23 fuze setters except for one thing—the corrector scale settings. With the M26, you use graphical firing tables to set in the corrections.

Let's go through a dry run on the operation—say for setting the M55A3 fuze for 25 seconds.

First... loosen the thumb-screw.



Then turn the handle so the index-ring moves around to a flat 25 seconds.



When the diamond shaped pointer reaches 25... stop and tighten the thumbscrew.

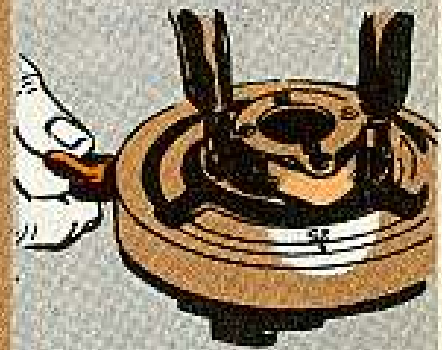

Repeat - tighten the thumb-screw.

Once you've fuzed the projectile and pulled the safety wire, you're ready to set the fuze.

What you do is slip the fuze setter on the fuze so that the setting pawl fits into the notch on the movable time-train ring of the fuze.

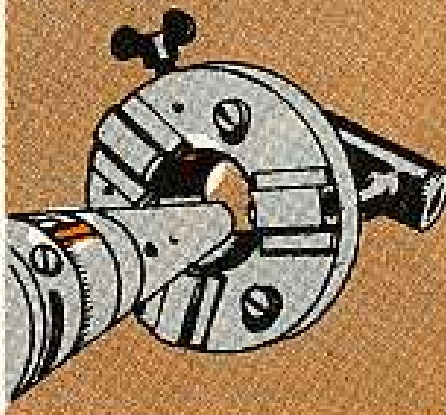

Then turn the fuze setter only in the direction of increasing time scale readings...



... until the stop pawl on the setter slips into the notch on the fixed fuze ring.

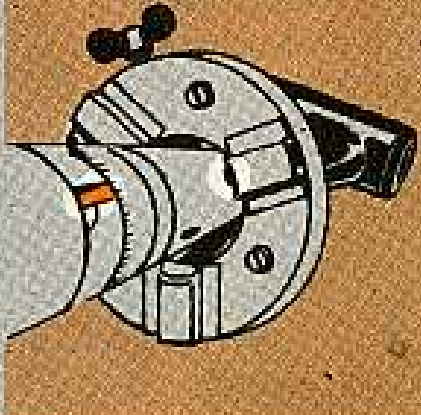

This keeps you from turning any more and means the fuze has been set. Then carefully lift the setter straight up so you don't foul up the setting.



If the settings don't agree, it could be you're trying to set a fuze that isn't meant for the M26. But, if you've done everything according to the book and you still get a different reading, reset the fuze to SAFE, replace the safety wire and then buzz Ordnance.



Keep your magnetron out of hock  
and you'll leave new ones in stock—

## IT TAKES CONNECTIONS



Those three balls on the pawn shop are important to some guys who need loot in a hurry.

And the three-ball cathode connector—like the one to the 5780 and 5795 magnetrons—is just as important to M33 FCS and Nike-Ajax guys. They know that if the connector fits loose on the cathode or is in the wrong position, the magnetron won't be long for this world. They'll tell you a fouled-up connection will mean arcing and a hot magnetron...and that's bad for the magnetron.

There are two right ways to make the connection, like so...

### RIGHT

### WRONG

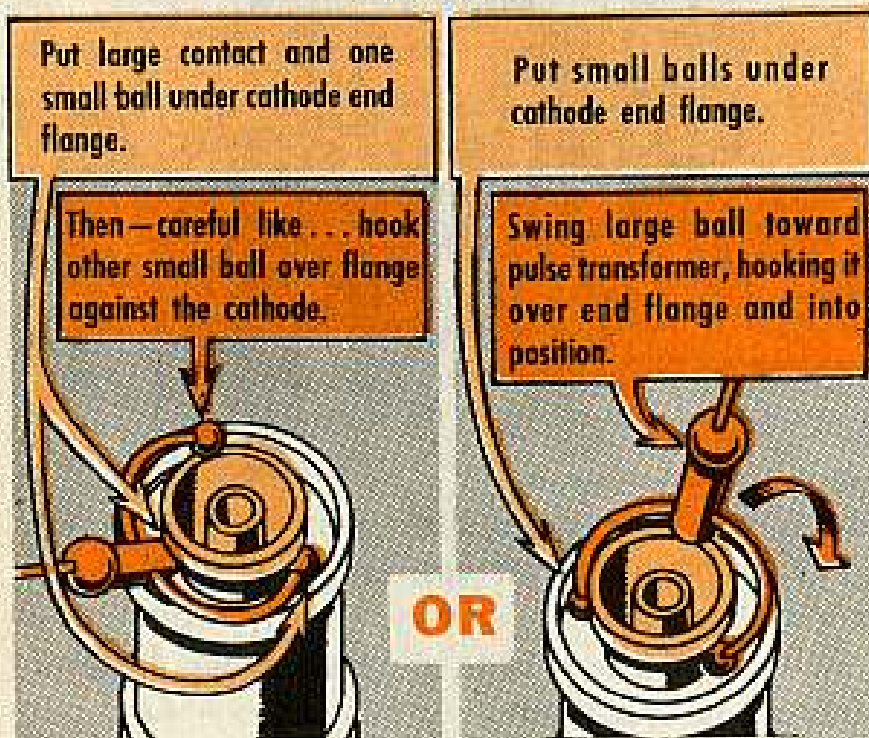

Make sure, with either of the right ways, that the three contacts of the connector are touching the cathode. And don't spread the balls apart. They stay that way and don't get the right contact.

## STOP STEPPING

Those radar and computer seat arms on the 75-mm M51 Skysweeper have a reason for being where they are. And the reason sure 'nough isn't for using the arm as a step to get to the top of the weapon.

The arms are for the protection of the operator when the gun is slewed—that's all.

When you use an arm as a step, the threaded stud gets bent and the adjusting serrations on the arm take a beating.

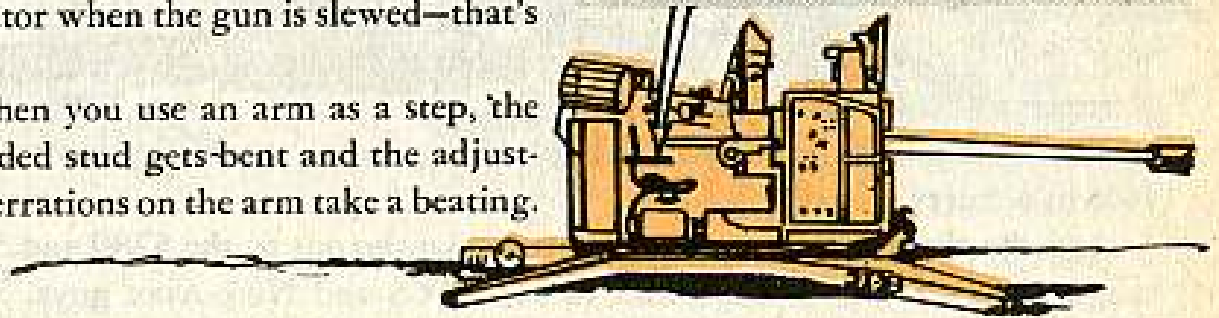
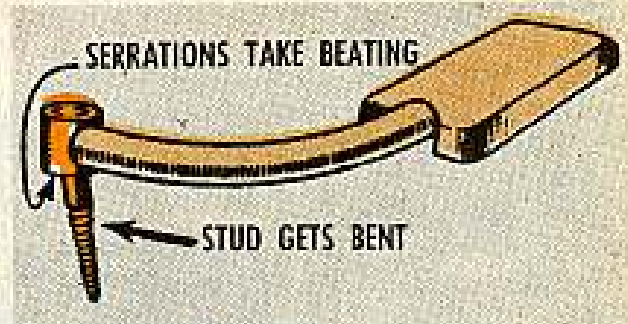

## SUCCESS STORY



If at first you don't succeed, don't try again. Not if you're trying to requisition the T38 log book (F350-8203711) for your Skysweeper FCS after it has been modified by Field Change 102.

They're not printing any more T38 log books, so when yours is filled up, you'll have to get the forms reproduced locally.

The M38 FCS log book is under FSN 1230-565-0934, and you ought to be able to get it now.



## NO SOAP

You missilemen can keep the GI soap in your kitchen.

Your support unit may have been using the soap to pressure-test the Nike-Ajax missile propulsion system for leaks. No soap no more. The stuff contains lye and lye corrodes.

Next time the man pressure tests the propulsion system, tell 'em to be sure to use wetting agent, FSN 6850-433-4042.

## NOT ONLY THE PIPE ASSEMBLY, BUT...

Comes the time when you have to take out the oxidizer fill-drain and vent plugs on your Nike-Ajax missile.

Then'll come the time when you'll put 'em back. That's when you brush some Fluorolube anti-sieze compound on the plugs so's it'll be easy to remove the plugs the next time.

You can get a supply of Fluorolube under FSN 9150-698-3820.



## PUT THIS IN YOUR PIPE

You never know when you're gonna pop-off a Nike-Ajax missile.

And you'd sure be red-faced if the missile got to flying around like a lost homing pigeon.

It can happen—if you foul up the pipe assembly on the missile by over torquing.

You know the pipe assembly... it's part of the ram pressure tube and runs inside tunnel 3 from the aft end of the nose section to the elbow on the guidance section shipping assembly. Over-torquing ruins the flange on the ram pressure tube... and that lets air sneak out of the tube. And that hissing might mean missing—the target.

So, don't torque the pipe on the shipping assembly more'n 30 inch-pounds.

And go easy when you remove and replace the pipe assembly. It's not meant to take a beating.

# CHEMICAL



*Where there's smoke...*

## **Watch out for fire**

Filling the small gas tank on the M3A2 smoke generator calls for a calm, steady hand on the gas can—specially if the smoker's mounted on a Jeep or a trailer.



Of course, the M3A2's have an overflow well to keep spilled gas from showering a hot smoker. It's the overflow well drain-tube you have to look out for. It juts down from the side of the smoker just below the gas tank.

When the smoker's on the ground, the gas overflow hits the dirt, evaporates, and there's not too much to worry about. But when the smoker's mounted, the drain tube has no choice but to splatter the vehicle's bed. That is, unless you use a piece of rubber tubing as an extension, running along the bed of the vehicle so the overflow will drain out. Three or four feet of rubber tube will do the trick. So will any other hose about the same size. But watch where you let the hose drain. Keep it away from the exhaust pipe.

You've got the same trouble with dripping fog oil (when you're feeding her more'n she can handle). If the stuff's allowed to collect under the smoker it can cause a hot flare-up.

The simplest way to keep from having a fire on your hands is to wipe up the overflow carefully each time you gas-up... and to keep the old mop chasing fog oil leaks until your smoker's adjusted the way it should be and stops dribbling SGF (smoke generator fuel).

To make sure you'll never overlook these important mop-up jobs, you'd best have a "Wipe Up" warning stenciled on top of the smoker's gas tank.

The nearest Chemical maintenance shop'll do the sign painting job for you, or maybe they'll lend you the stencils so you can do it.

Just use white, 1/2-inch letters saying:

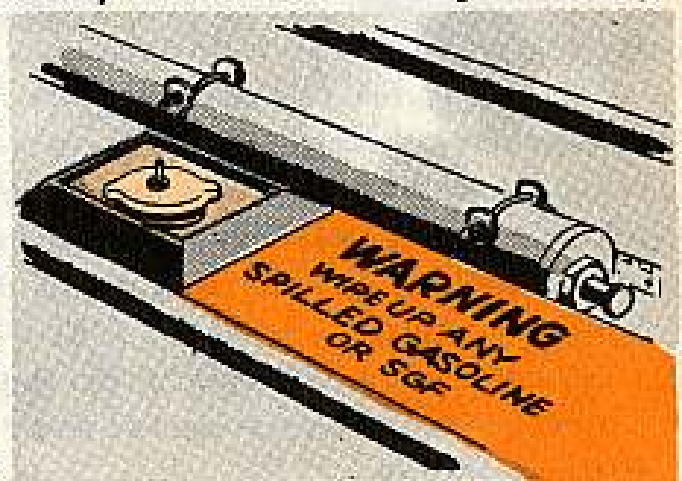

With a little care you can learn to gas-up "by ear." It'll help you keep gas overflow to a minimum and thus reduce the danger of fire. Just try these notes for size:

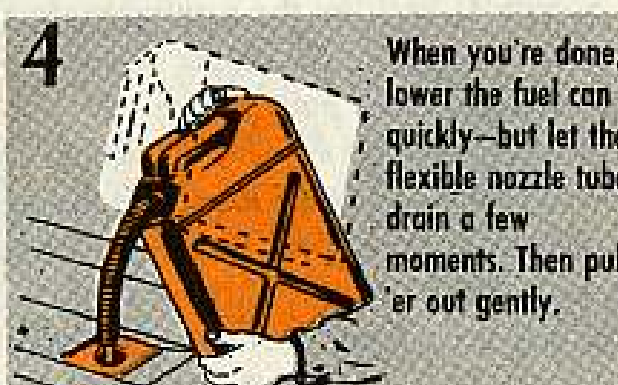
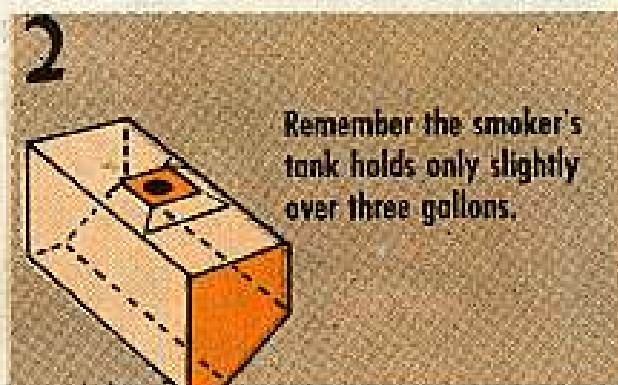

## Barrel skids

Dear Connie,

Now that they've declared our M1 barrel skid obsolete, what do we use to replace it? We still have to load these 55-gal drums of fuel and fog-oil—and that's dangerous, back-breaking work without a skid. What do we do—make our own?

Sgt R. W.

Dear Sgt R. W.,

No need to strain any muscles on those drums. Get a barrel skid from the Quartermaster Corps. They come in three different lengths, but you'll probably want the 10-footer. Give these numbers a try:

Skid, barrel, 10-ft, FSN 3990-184-3352.

For a six-footer, use FSN 3990-184-3351. And for a 12-footer, give 'em FSN 3990-184-3353.

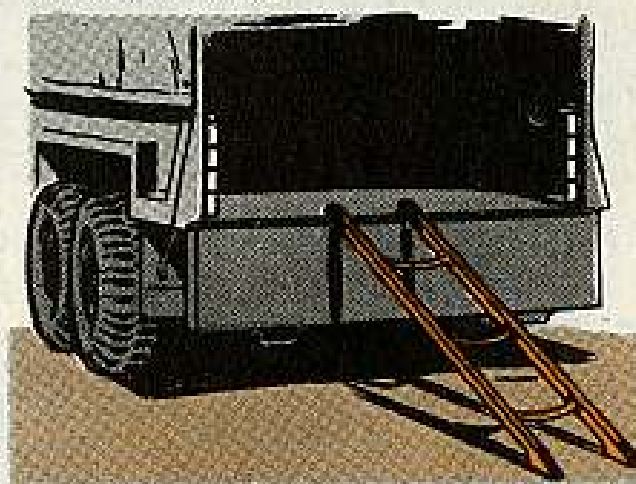

SR 735-30-1 tells you how to request items that aren't in your TOE.

Connie



## QUARTERMASTER



Don't Pack Trouble Into...

### Your Old Kit Bag

So you're back on the ground—safe and sound—and your heart's dropped out of your throat. You're eager to assemble, fall in and scoot—but there's still the job of recovering your 'chute.

And doing it the right way will not only make it easier and faster for you—it'll take a load of sweat off the shake-out artists and maintenance men who'll be preparing it for repacking. Those guys deserve all the breaks they can get, since they go to fantastic lengths to let you down easy. With just a little care on your part, you can keep from letting them down at all.

#### TAKE THE QUICK-RELEASE ASSEMBLY, FOR EXAMPLE:

That's a pretty delicate little mechanism, and it needs a lot of attention to keep it in shape. Any time it's dragged through the dirt or sand, it means extra work for the maintenance crew.

You can help a lot by placing the harness in the kit bag before you begin your recovery, and making sure you don't drag it out into the dirt.



As for the recovery, the right way is always the best.

After stowing the harness in the bag, you pull a flanking attack on the canopy and sneak up to the apex. Naturally, you don't step on the chute.

You grab the apex by the bridle loop and gently pull and riffle it until the canopy and suspension lines are in a long, straight line.

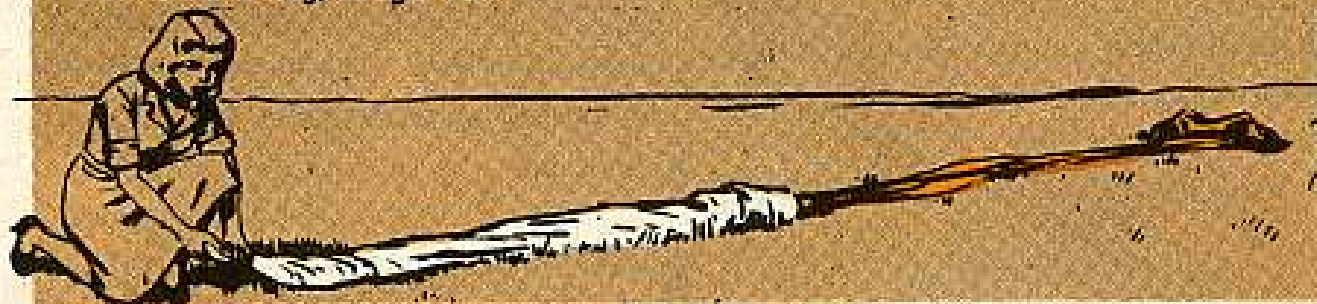

You've gotta be mighty careful to keep from snagging the canopy on something and tearing it. If it snags, don't keep pulling—go back and release it. The extra minute you might take here can save hours of maintenance work later on.

With the chute straightened out in a more or less thin line, run a thumb through the bridle loop and stretch both arms out to the side—like a scarecrow.



Then start walking toward the kit bag, folding the canopy and suspension lines in figure-eight fashion.



When the whole works is wrapped in your lovin' arms, put it to bed in the kit bag on top of the harness.

KEEP THE BRIDLE LOOP HOOKED TO YOUR THUMB.



This way, when you remove your hand after stuffing the bag, the bridle loop will be on top.



Which means the shake-out man can hook right on to it and hoist the canopy without dumping the kit bag and searching all over for the loop.



Follow up your recovery by stowing the reserve chute on top of the kit bag. And you're ready to roar.



Your Engineer transit depends on you  
to — **KNOW ALL THE ANGLES**



Handling and operating an Engineer transit calls for really being on the level and knowing all the angles.

That little precision instrument is as delicate as a card-shark's fingers when she comes up with those elevation and azimuth readings for you. But this surveying business is a two-way deal. You can't expect a transit to do all that work for you—and do it right—unless you do a little work for her. She needs careful handling, storing, care and cleaning. Those precision hunks of metal cost a lot of dough, too... and a statement of charges would mean a light-dying Eagle for many a payday.

**HANDLING**

Goofing up a transit with rough handling is easy as cracking a fresh egg in a vise. You've really gotta be careful.

Take putting her away in the box. There're two important things to remember:

1. The box should close easily—with no binding. That means the instrument must be



in the right place. Any time you close or open the box and feel any tension or binding, halt everything and check her out. Something's sure to be in the wrong place... or in the right place the wrong way.

2. On a front-opening box, always put the vertical circle on the inside. That protects the



**RIGHT**

**WRONG**

circle from being hit by tools on the inside of the door. Putting the vertical circle on the outside and having something press against it—like the plumb bob—will give you a no-go transit every time. So keep a sharp lookout. The K&E transit, 1-minute reading, with night illumination, is an exception to this rule. Its vertical circles goes on the outside. If you put it on the inside, the battery box located right next to the circle will prevent the door from closing.

Another thing about putting her away. Loosen the leveling screws and center the shifting-plate in the footplate. Screw the leveling screws down on the footplate with light tension. Make sure the screws stick out below the leveling head the same distance.

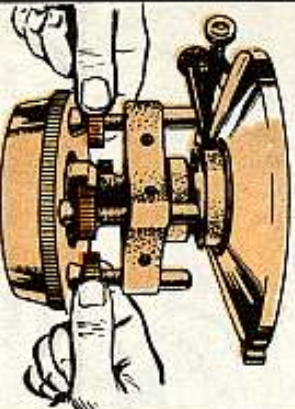

The box is made to carry only authorized equipment. Don't slow your other gear in it.

A guy who paid his own dough for the instrument doesn't toss it in the back of a truck... or even set it there. The transit would get jolted around and get out of whack.

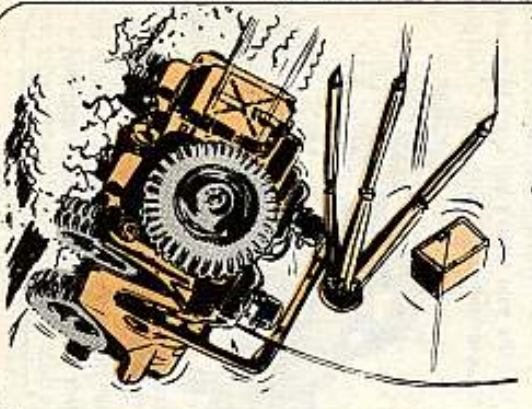

**TRAVELING**

So you're taking your little old transit and going out on a field problem. Remember what a civilian surveyor who goes for his own transit does when riding in a truck or other vehicle? He sits down, puts the transit in his lap, and holds on with a death-like grip. Which is



the right—and only—way to carry a transit in any vehicle.

**ON THE JOB**

Any time your transit isn't being used, keep the cover on. Keeps out dirt and stuff.

Generally, when you carry her from one place to another, you just sling the transit over your shoulder. That's OK in open country. But if you're walking through brush or trees, hold the transit low and in front of you. That way



you'll keep from knocking it against a tree limb or something. Any time you're carrying her, be sure the clamps are tightened lightly.



Remember how those wing nuts on the tripod are handled.

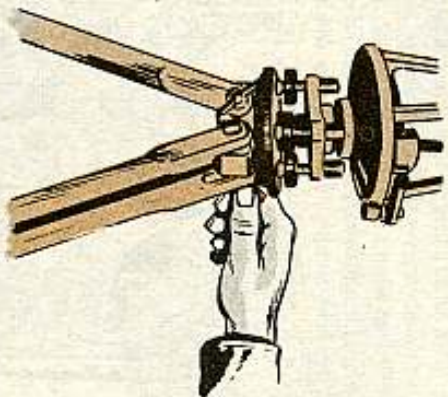

With the transit set up ready for use, the wing nuts at the top of the legs are screwed down snugly—with light tension.

While you're taking readings, look and feel sharp for any binding or unusual operation. At the first sign of trouble, report it and turn your instrument in to be looked over by higher echelon. Trying to operate her when she's fouled up will make the trouble worse.



Easy does it when tightening any of the clamps, leveling screws, or wing nuts. They have real delicate threads—it takes only a little too much pressure to mess 'em up. When moving parts are clamped, turn 'em only with the proper tangent screws.

### AFTER OPERATION

At the end of every day, there's some care and cleaning to do so she'll be ready for the next day.

1. Use your camel's-hair brush to remove dirt and stuff from optical parts. Then use



lens tissue. Never clean the glass with cloth. The little dirt particles act as an abrasive under the cloth and scratch the glass. The brush and lens tissue get off dirt without scratching.

2. Wipe all other external parts clean with a soft cloth.

3. Use the camel's-hair brush again to remove any particles caught in moving parts. Double-check the vertical circle. Tiny bits of dust and dirt caught there grind up those delicate parts when the circle's turning.

4. Wipe the exposed threads on the leveling screws clean.



5. Put the protecting cap on the tripod after removing the transit.

6. If your tripod has collapsible legs, fold 'em and strap 'em together.

7. If it has non-collapsible legs, lay the tripod down. Never stand it up in a corner or lean it against something. It might fall and bang up the legs.



8. Loosen the wing nuts on your tripod before putting it away. Moisture and heat could cause the wood to swell against the tight screws and split or damage the legs. Remember that your delicate transit takes the gentle touch all the time. Treat her like a balloon in a pin factory.

Another very important thing: Never disassemble your transit. More harm can be caused that way—by dirt getting inside when she's torn apart—than is caused by years of operation.

### MAKE A TRADE

Dear Sgt Dozer,

Where do we get parts to do minor repair work on wrist compasses and lensatic luminous dial compasses?

SFC G. W. S.

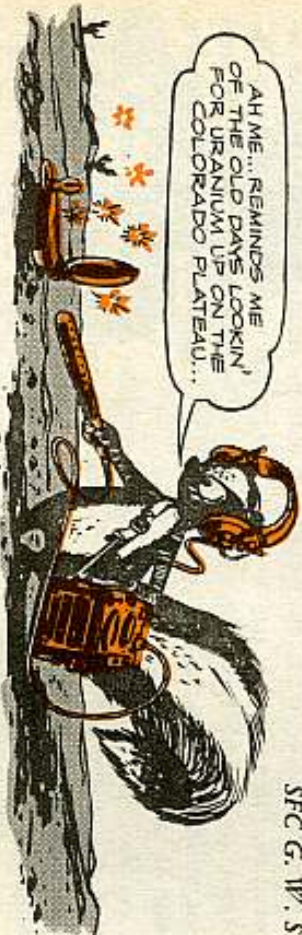

Dear SFC G. W. S.,

You don't get any parts. There's no repair of those compasses in any echelon. The kaput compasses are turned over to the supply officer, who'll ask the Chemical guys what to do with 'em—like it says in AR 7.5-380. The compasses get special treatment 'cause they contain radioactive stuff.

Never leave your transit unattended. Anything's likely to happen to her standing out in the boondocks unguarded and alone.



# CONTRIBUTIONS

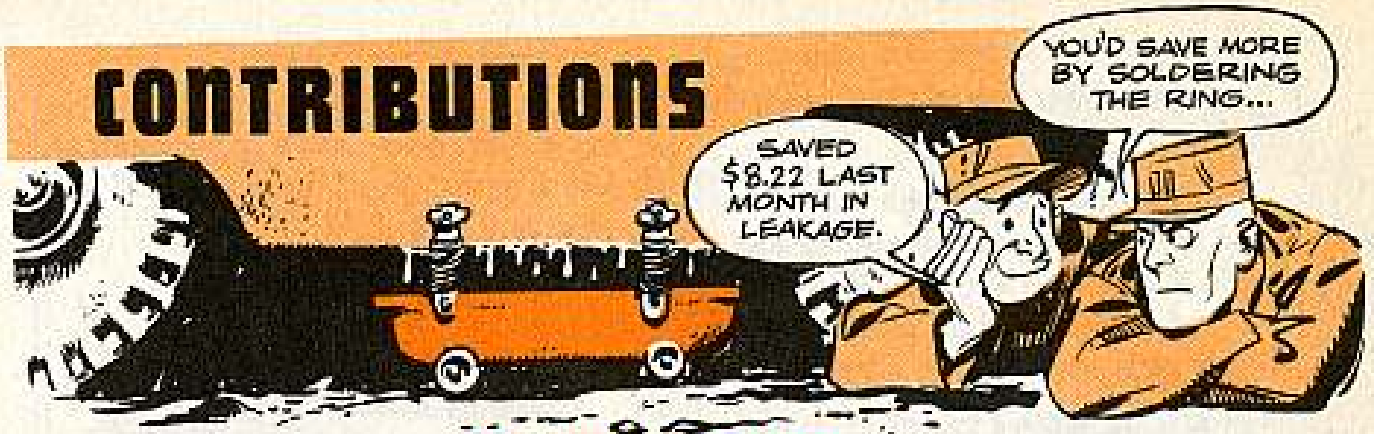

## SAGGING SOLDER

Dear Editor,

I'd advise those people with the M38A1 Jeep to look under that driver's seat—at the top of the gas tank. We found that gas was leaking where the fuel filter element goes into the tank.

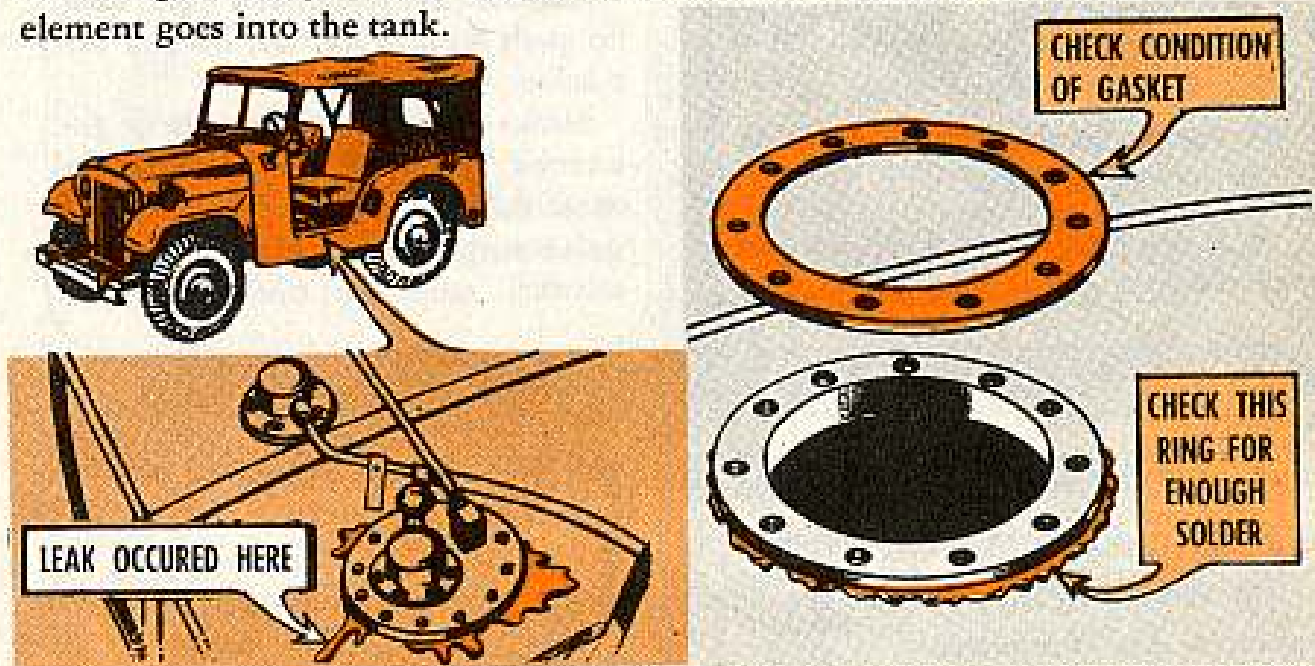

At first we thought that the trouble lay with the neoprene gasket that goes between the filter assembly and the tank. This proved wrong—the gasket was OK. After taking the filter assembly out of the tank, we spotted the trouble—the steel ring which supports the filter in the tank had broken loose from its soldering bond on the tank.

Appears as if there wasn't enough solder put on the inside and outside edges of that steel ring and on the tank. So, cracks started and gas began leaking. We also found quite a bit of rust between the ring and the tank where there's no solder bonding.

So, to fix 'er up, we cleaned all surfaces of the ring and tank real good—and then tinned these surfaces to make a tight solder joint. Since then, no trouble.

Mr. H. Allen  
Fort Ord, Calif.

*(Ed Note—Thanks for the info. One safety tip, tho. Give para 17 of TM 9-2852 a look-see before soldering. It'll tell you what precautions to follow.)*

## MAKE YOUR POINT

Dear Editor,

We've come up with a real simple way to get a close-in known Datum Point for the 90-mm and 120-mm AA guns.

What we do is finish the leveling and back sighting and then line up the marker on the top carriage with the one on the pedestal. The markers are the same ones used to center the piece for march order.

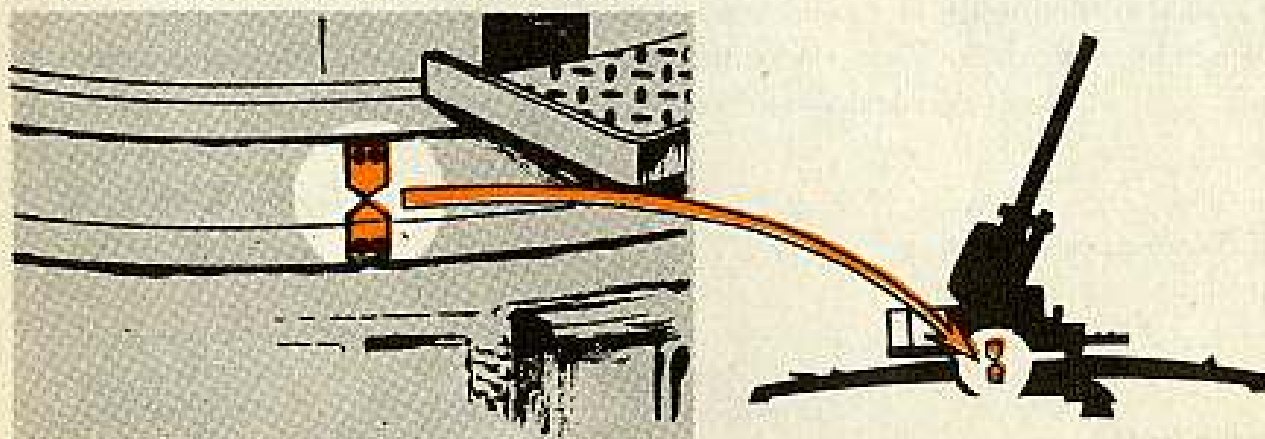

Then you record the reading shown on the azimuth clock. This gives you a good way to check the orientation of the azimuth clock at night or on days of poor visibility.

You can use the same setup with the M33 FCS by adding the markers to the track azimuth drive cover and the van roof.



One more thing . . . if the points on the markers aren't close enough to each other for easy checking, try drawing a straight line between them.

**Btry C**

**96th AAA Bn**

*(Ed Note—Real deal. You might cover the markers with luminous tape (FSN 8305-282-7867) when the system is first oriented and remove the tape when the march order is given.)*

## NO...NO...NOT THAT!

Dear Editor,

Pressure in the G744-series 5-ton transmission is like a gurgling volcano—both are building up power to blow.

We've found that there are two things that keep that transmission pressure where it should be—transmission breathers and the control valve's exhaust port. A combination of either a clogged breather and a plugged-up exhaust port, or a clogged breather and a leaky control valve—and that pressure buildup starts. If the pressure gets high enough, gear lube is forced into the clutch housing or past the rear transmission seal—could even blow the seal.

We take a quick look-see every so often in between our regular services to guard against clogs and leaks—and our blow-up insurance is now doubled.

MSgt R. Post  
Camp Kilmer, N. J.

*(Ed Note—Safe habit to get into.)*

## CATCH THE BALL

Dear Editor,

In the past, we sometimes had difficulty removing worn-out tie-rod ends. It was particularly difficult if the ball came loose in the taper and turned when we tried to remove the retaining nut.

We solved the problem by removing the grease fitting and running in a junk bolt that'll fit. This bolt bears on the ball and locks it to the socket while we unscrew the nut. Since the worn-out part will be discarded anyway, the slight damage to the threads doesn't matter.

TSgt Alvin R. Roberts  
Alabama ANG

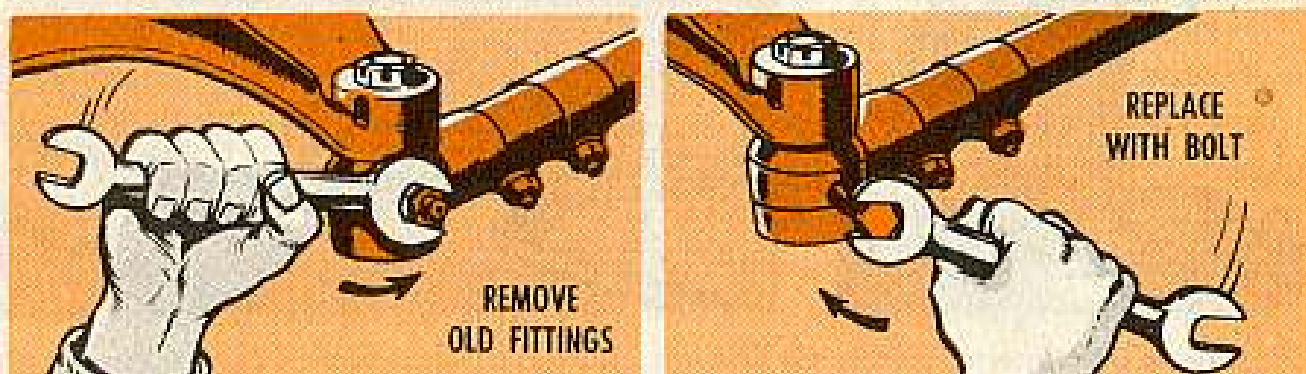

*(Ed Note—This is lots easier than trying to jack a loose tie-rod end back into place to hold it while you take off the nut. For a 1/8-in NPT grease fitting you want a 3/8-in 24 NF bolt. The fitting has 27 threads to the inch, the bolt only 24, but they'll go together with a little force. O'course, y' only do this to worn-out tie-rod ends you're gonna replace—and then only if they're loose in the taper.)*

# Connie Rodd's BRIEFS



## *Your puller jam?*

Does your universal wheel puller FSN 5120-449-3770 (Ord Stock No. 41-P-2960) jam when you get a real heavy pull on it? Slick it up: Put some oil on the forcing screw before you use the puller.

## *Stash the sash*

Havin' trouble locating that Brush, sash tool, oval, that was listed in the General Mechanics Tool Set in PS #51? It's now an Engineer item and it's called Brush, paint, oval, hog bristle, w/chisel edge, FSN 8020-239-0959.

## *Use your index*

Want to keep up with and make sure you have the latest supply manuals? Then check these Department of the Army Pamphlets regularly: Signal, 310-21; Transportation, 310-22; Chemical, 310-23; Engineers, 310-25; Ordnance, 310-29; Quartermaster, 310-30. And don't forget the changes.

## *Accey-deucey*

There's a new rule book on maintaining administrative vehicles... but it's an accey-deucey setup. Superseding TM 38-660 (20 Apr '50) is a dual set of manuals: TM 38-660-1 covers instructions for the operator and TM 38-660-2 lines out the **organizational maintenance** procedures. The new type manuals came out 16 Apr 1957.

## *Tow talk*

Here's some more info you can add to your wealth of knowledge 'bout towing G749-series 2½-ton Hydra-Matic trucks rearward with all wheels on the ground. When you gotta tow this truck a short distance—like when getting it into position in a motor pool—put the transfer lever into DOWN NEUTRAL



position and the transmission shift lever into R (Reverse). This dope is for towing short distances only—TM 9-8024 clues you in on the other distances.

## *Wha'cha doin'?*

It keeps ya' busy for most of the day... so why not find out just what your job covers. AR 611-201 (Mar 55) describes pretty near every enlisted MOS in the Army. Before reading it, make sure it's up-to-date—with all **eight** changes.

## *It's a steel*

Wouldn't you say that sheet steel was a heckuva lot easier to take care of than wood? Well, that's just what you can have in your ½-ton commercial pickup trucks—you can cover that wooden cargo floor with sheet steel. TB Ord 647 (27 July 56) gives you the go-ahead—and you can buy the stuff you need on local purchase under SR 715-110-50.

## *Able cables*

You Nike-Ajax guys want to be doggone sure you remove the cosmoline from the cables of new acid and fuel servicers. Use volatile mineral spirits like it says in TM 9-5001-30 to get the stuff off. Then coat the cables with corrosion preventive compound, class 3, the soft film kind, for preserving and lubing. FSN 8030-231-2353 gets you a 5-lb can.

## *Access plug*

When you replace the Pipe-threaded access-plug in your 100-ampere AC-DC regulators after adjusting the system, be sure it gets coated with the right type of dope.

What you want to use to keep the box waterproof is Gasket Forming compound: Paste, oil and water-resistant, 11 oz tube (net wgt), FSN 5330-252-3391. If supply hasn't got any right handy, better get some ordered and kept within reach when needed.

WELL I'LL BE  
A **SWITCHED WITCH**...  
IT WORKED!



**THIS TM'S GOT MAGIC BEAT A MILE**  
Man, am I a crazy mixed up witch!

I'm cruising on my broomstick after a slow night on a graves registration detail, when I catch an AUS boy tryin' to coax some life into a jeep. I lower my wheels and come in on this character. "I'll give it a shot of Hex #4," sez I. "Save it," sez he. "Just hold this TM up to the light and read to me from paragraph B page so-and-so." Well, sir, in a flash the jeep was fixed. "How do you get this book?" sez I. "Easy," sez he. "One simply orders it (on DA Form 17) from the Supply Manual, like any other nut or bolt."